

SPEAKMAN®

SE-925 DRENCH HOSE

DESCRIPTION

The SE-925 wall mounted drench hose featuring stay open valve, single aerated spray with automatic flow control, 12' recoiling hose and flip-top dust covers.

SPECIFICATIONS

Spray Head: Yellow ABS plastic spray outlet with flip-top dust cap and an automatic flow control

Valve: 3/8" NPT female brass, chrome-plated

Activator: Brass, chrome-plated squeeze handle

Hose: 12' recoiling hose

Flange: Brass, chrome-plated

Inlet: 3/8" NPT male, swivel connection

Performance: 1.6 gpm @ 30 psi

Compliance: ANSI Z358.1

Universal Emergency Sign Included

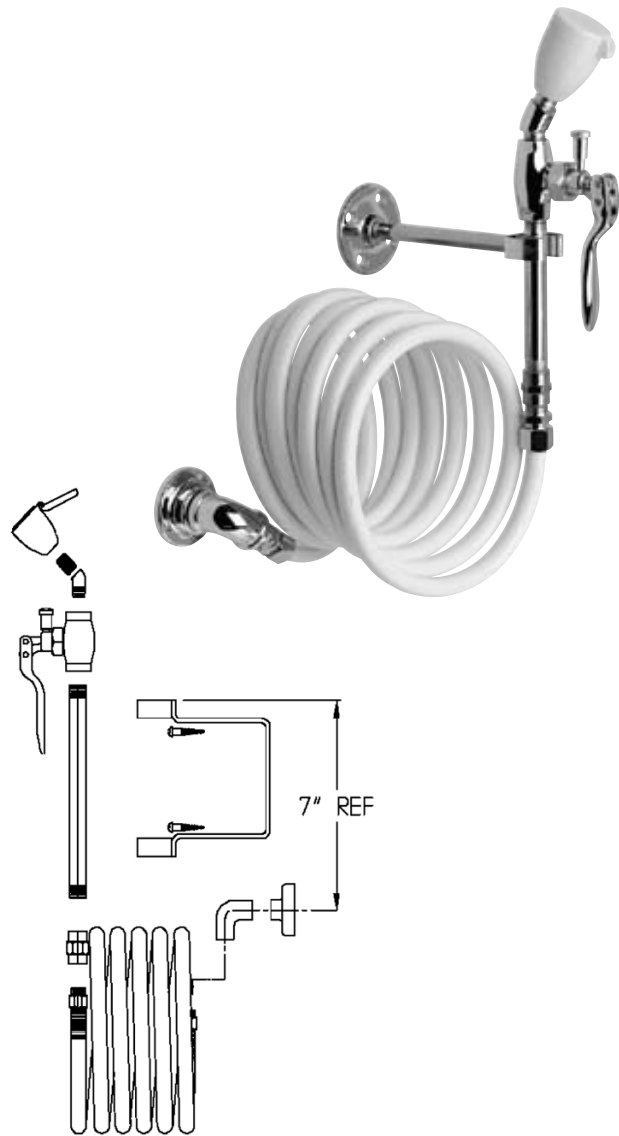

OPTION

VB Vacuum breaker

Job Name _____
Location _____
Architect/Engineer _____
Sales Representative _____
Wholesaler _____
Date _____ Model # _____