

SPEAKMAN COMPANY
SE-920 Installation, Maintenance & Operation Instructions
EYESAVER® LABORATORY DRENCH HOSE

DESCRIPTION

Laboratory drench hose supplied with aerated spray head with flip-off dust cover, and self-closing valve activated by squeeze handle.

SPECIFICATIONS

SPRAY HEAD: Aerated, Yellow ABS Plastic Spray Outlet, Dust Cover.

VALVE: 3/8" NPT Female Brass, Chrome-Plated. Self-Closing.

ACTIVATOR: Brass Chrome Plated Squeeze Handle.

HOSE: 6' Reinforced, 750 PSI Burst Pressure, Integral Hanger for Valve.

INLET: 3/8" NPTM with Swivel Connection.

SHIPPING WEIGHT: 2.49 lbs.

EMERGENCY SIGN: 7-7/8" x 7-7/8" Plastic Wall Sign.

OPTIONS

◇ SGN4 (Eye Wash Floor Sign)	◇ TEW (Twin Eyewash Spray Heads)
◇ SSHSE (Stainless Steel Hose)	◇ VB (Vacuum Breaker)

INSTALLATION

This unit is completely assembled and tested before shipment. Connect a water supply to the unit (use pipe sealant on connection) that is an uninterrupted source of potable water. Failure to use potable water can result in emergency units producing impure or contaminated water causing possible further injury.

OPERATION

The drench hose is activated by applying pressure to the valve handle. The self-closing valve will open and an aerated flow of water will discharge from the outlet. Water will continue to flow as long as the handle is depressed. Once pressure on the handle is released, the valve will immediately shut off.

TESTING PROGRAM

The American National Standards Institute (ANSI) states that all safety emergency equipment shall be activated on a weekly basis to flush the line and verify proper operation. Speakman Company furnishes a testing record tag (91-0635) with each unit. On this tag the date of inspection and the inspectors initials should be noted.

MAINTENANCE

Should you need parts to repair this unit, please reference the parts listing below for correct part numbers. Before any maintenance is done *be sure to shut the water supply off.*

WARNING: Use only genuine Speakman parts when repairing or replacing components. To order parts call 1-800-537-2107.

SE-920 REPLACEMENT/REPAIR PARTS

<u>ITEM</u>	<u>PART/GROUP #</u>	<u>DESCRIPTION</u>
1	RPG38-0379	Spray Head Assy.
2	05-1177-PC	Aerator Assy.
3	31-0356-RCP-PUR	3/8" x 1"lg Brass Nipple
4	G20-0584-PC	3/8" NPT Valve for SE-920
5	G63-0065-PC	6' Reinforced Hose Assy. with Integral Holder.

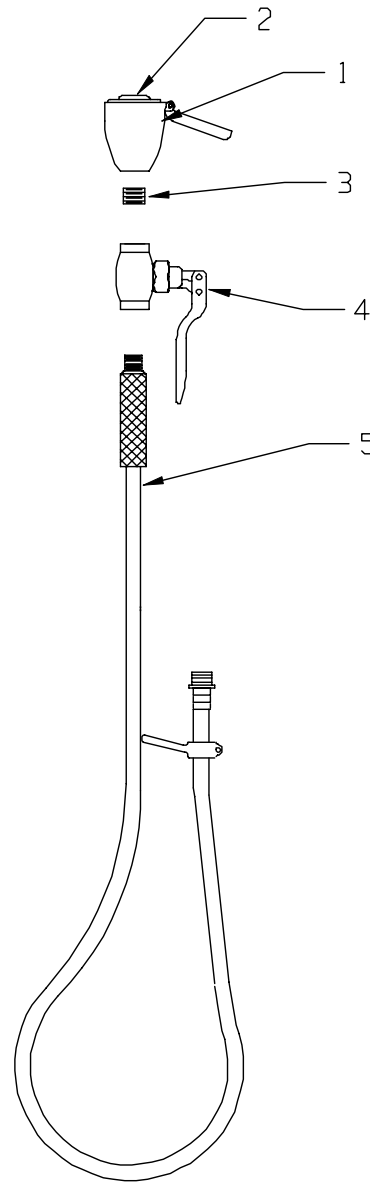

FLOW DATA

DRENCH HOSE:

FLOW PRESSURE PSI (BAR)	30 (2.07)
FLOW RATE GPM (LPM)	1.6 (6)

NOTE: This unit should be connected to an uninterrupted source of potable water, with a minimum flowing pressure of 30 PSI and a maximum static pressure of 125 PSI.

Note: All units meet existing ANSI Z358.1 Standards and OSHA Rules. Product improvements may cause specification and dimensional changes without notice.

SPEAKMAN®
 PO Box 191 Wilmington, DE 19899 Phone: 800-537-2107 Fax: 800-977-2747
 Visit us on the web at www.speakmancompany.com