

SPEAKMAN COMPANY

VS-113010 Installation, Operation, & Maintenance Instructions VERSATILE™ COMBINATION SHOWERHEAD SYSTEM

DESCRIPTION

VERSATILE™ chrome plated brass 2-way shower diverter. S-3010 chrome plated plastic fixed showerhead assembly. VS-3010 chrome plated plastic hand held showerhead assembly. 61" vinyl hose assembly with built in vacuum breaker. S-2540 bent chrome plated shower arm. S-2540 chrome plated shower arm flange. Chrome plated wall mount (screws & anchors included). ½"-14 NPSM and NPT threads. Two (2) operational diverter settings. No flow control in diverter. 2.5 GPM (9.46 L/min) flow controls in showerheads. Teflon Tape provided. Meets ASME A112.18.1/CSA B125.1 standards.

SPECIFICATIONS

Supply Inlets/Outlets: ½" -14 NPTF & NPSM Threads
Flow Rates: 2.5 GPM/ 9.46 LPM MAX.; 2.0 GPM/ 7.6 L/MIN MIN.
Shipping Weight: 0.6 LBS.

OPTIONS

◇ BN – Brushed Nickel Finish
◇ E2 – 2.0 GPM Flow Rate

INSTALLATION

1. Install the shower arm with flange into the existing behind the wall piping. Shower arm threads are ½"-14 NPT, both ends. Adjust flange so that it rests against the exposed side of the wall. 2. Screw the 2-way diverter's brass coupling nut onto the shower arm by turning it in a clockwise direction. **(Final positioning of diverter calls for hand held outlet to face away from installer)** Make sure the sealing washer is inside the brass coupling nut to prevent leaks. **(Hold diverter body in final position with hand while tightening coupling nut to prevent damaging diverter by over tightening)** 3. Install the wall mount using the screws and anchors provided or double-sided tape that can be purchased at most hardware stores. **NOTE: the location of the wall mount is optional but restricted by the 61" hose length running from the diverter to the hand shower.** 4. Screw your fixed showerhead assembly (S-3010) onto the bottom outlet of diverter by turning it in a clockwise direction. 5. Screw the side of your hand held showerhead hose with built-in vacuum breaker onto the back outlet of diverter by turning it in a counterclockwise direction. 6. Connect the free end of the hose to your hand held showerhead (VS-3010) and place head into wall mount. **(Make sure sealing washers are inside the hose connectors at both ends to prevent leaks)** 7. Turn on water supply and check all connections for leaks. 8. To operate the diverter with water supply on, pull out circular handle to divert the water to the hand held showerhead only. Push the circular handle in to divert the water to the fixed showerhead only.

MAINTENANCE

Your Speakman showerhead is designed and engineered in accordance with the highest quality and performance standards. Periodic cleaning using a mild soap and warm water will help keep your showerhead's appearance in its original condition. For best results, dry immediately with a soft, clean cloth. **Do Not Use** harsh and/or abrasive cleaners on showerheads. To help restore your finish, occasionally apply a non-abrasive wax to your showerhead body (Follow manufacturer's instructions). In certain water conditions, mineral deposits may form on your faceplate. To reduce the mineral build-up, turn the handle to **FLOOD** position to let the water drain out after every use. A gentle scrubbing of the plunger or channels with a toothbrush should restore your spray pattern. On **chrome** plated showerheads, a white vinegar/water treatment will assist in breaking down excessive mineral deposits on the sprays. The showerhead faceplate can be soaked in a two (2) parts white vinegar and (1) part water solution for about ½ hour to break up the mineral deposits. Rinse thoroughly. Brush off any remaining mineral deposits if necessary. **CAUTION:** On all special finish parts, including any of the nickel or brass finishes, the white vinegar/water treatment should not be used.

ROUGH-IN DIMENSIONS

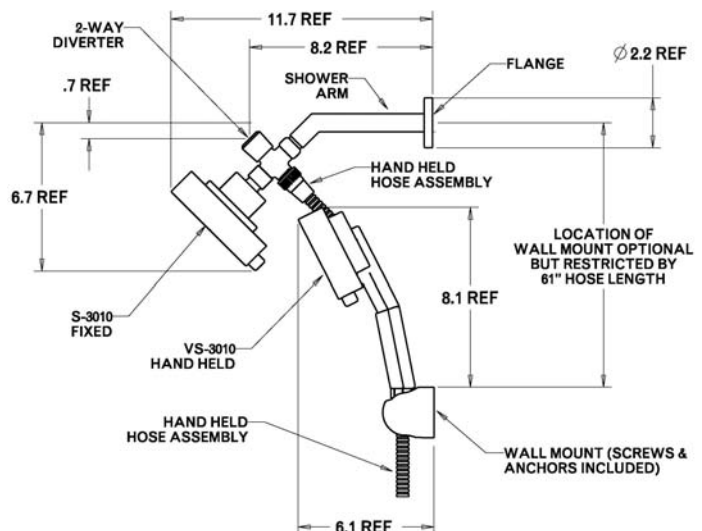
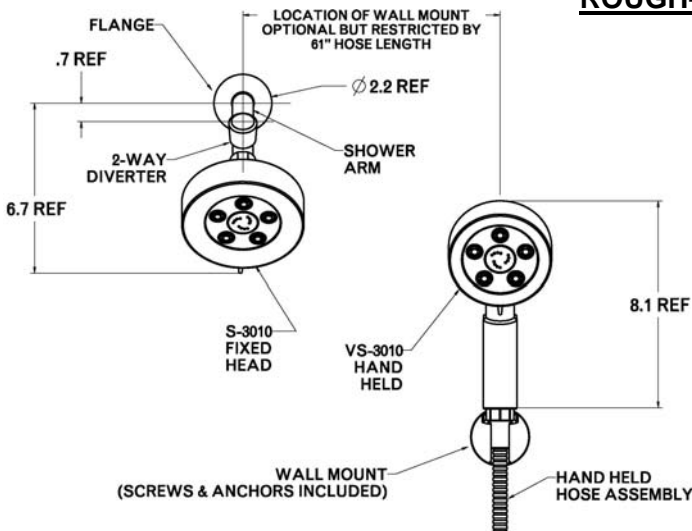

Product improvements may cause specification and dimensional changes without notice.

SPEAKMAN®

PO Box 191 Wilmington, DE 19899

Phone: 800-537-2107 Fax: 800-977-2747

02/11
92-3215 Rev-1

Visit us on the web at www.speakmancompany.com