

# SPEAKMAN COMPANY

## **Sentinel Pro Thermostatic/Pressure Balancing Valve, Showerhead, Tub Spout, & Combo Series Installation, Operation, & Maintenance Instructions**

### DESCRIPTION

Speakman Sentinel Pro concealed anti-scald thermostatic/pressure balancing shower /bath valve & combinations. Chrome plated brass wall plate. Chrome plated metal lever handle. Adjustable temperature limit stop ((TLS) Factory set @ 110 F°). Brass body with integral spring check stops. Thermostatic element/piston type pressure balancing cartridge assembly. Can be installed back to back. Roughing-in template. S-2272-E2 showerhead (If applicable), S-2280 Anystream wall mounted showerhead (If applicable), or VS-100 Handheld Shower (If applicable) with flow control device reduces flow to 2.5 GPM/9.46 LPM maximum to meet existing ASME A112.18.1/CSA B125.1 Standard. Chrome plate brass shower arm and wall flange (If applicable). Chrome plated tub spout (If applicable). Four port valve with ½” female copper sweat inlets and shower outlet. ½” NPT female tub outlet. Meets ASME A112.18.1/CSA B125.1 & ASSE 1016 standards.

### SPECIFICATIONS

SUPPLY: ½” FEMALE COPPER SWEAT INLETS & SHOWER OUTLET; ½” NPT FEMALE TUB OUTLET (VALVE)

FLOW RATE: 2.5 GPM/9.46 LPM MAX. (SHOWERHEAD AND/OR HANDHELD SHOWER, IF APPLICABLE)

SHIPPING WEIGHT: 5 LBS (SM-5000)

### OPTIONS

◇ 1 - S-2251 Showerhead	◇ 6 - S-2288 Showerhead	◇ AP - Anchor Plate (S-2280 Showerhead Only)
◇ 2 - S-2252 Showerhead	◇ 9 - S-2292 Showerhead	◇ BJ - Ball Joint (S-2280 Showerhead Only)
◇ 2VR - S-2252 Vandal Resistant Showerhead	◇ PC – Polish Chrome Handheld Shower (Combo w/VS-100 Only)	◇ VH- White Vinyl Hose (Combo w/Handheld Shower Only)
◇ 3 - S-2253 Showerhead	◇ LH - Less Showerhead	◇

### INSTALLATION INSTRUCTIONS

**Important-** Read these instructions before installing the valve. Use the correct “Rough-in Diagram” for the unit that is being installed. Maximum water pressure: 125 PSI static; minimum water pressure: 20 PSI flowing; minimum cold supply temperature: 40° F; maximum hot supply temperature: 160° F; minimum hot supply temperature: 5° F above set point. Use a suitable sealant on all threaded connections and when soldering, it is recommended to remove the integral check stop valve parts and VC/DIV cartridge (If applicable). The valve rough-in adjustments are 2-1/2” to 3-1/2” from the finished wall to the centerline of the hot & cold inlets of the valve body.

- 1) Referring to the correct “Rough-in Diagram” for the unit that is being installed (See the back page or the separate insert sheet), install the hot & cold supply lines for the valve, making sure they are on an accurate horizontal plane. Taking the valve assembly, making sure the “UP” on the valve bonnet is in the up position, connect the hot supply line to the left side of the valve & the cold supply line to the right side of the valve (Note that for Back- To-Back valve installations, the hot & cold supply lines are reversed on the opposite valve). Make sure the valve is straight, level, & positioned properly in the wall (See Figure 1). See Page 3, Figure #4 for “Back-To-Back” valve cartridge installation instructions.

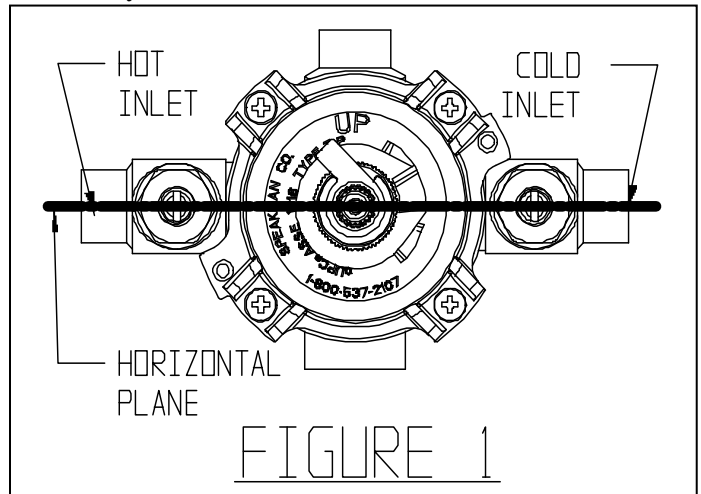

- 2) Slip the rough-in template over the valve control spindle. If the opening in the wall is smaller than the outside diameter of the template, trace the outside diameter of the template, remove the template, and recut the opening in the wall. Slip the template onto the valve again until the template bottoms out on the top of the valve bonnet (See Figure 2). Note- When installing a valve with the built-in volume control/diverter feature, make sure the template is positioned so the brass “VC/DIV” spindle is in the relieved area of the template. The finished wall should fall between the minimum and maximum limits of the template if the valve has been installed properly. Leave the template in place if the finished wall has to be installed. The template will insure the proper size opening for repair accessibility, as well as protect the valve from damage during the finished wall installation.
- 3) Install the rough piping and transfer valve (If applicable) to the shower and/or tub outlets of the valve. If the installation is only using one outlet, be sure to plug the other outlet with the provided pipe plug. Check connections for leaks. If applicable, construct the finished wall.
- 4) With the necessary opening(s) in the finished wall, assemble the accessory(s) to the rough piping (**Important-** See separate “Accessory Installation Instructions” supplied with some of the accessories). With the rough-in template removed & the valve turned OFF, turn both the hot & cold water supplies ON. Using the handle, operate the valve checking all the connections for leaks.
- 5) The maximum hot water temperature setting adjustment (Temperature Limit Stop (TLS)) of the valve has been factory set at 110° F. **Important- Check each valve installation with a thermometer to make sure the maximum hot water temperature is set to the recommended setting of 110° F maximum.** To lower the limit of the maximum hot water temperature the valve delivers, adjust the valve’s temperature limit stop (TLS) plate (See Figure 3). Slip the retaining o-ring and the TLS plate towards the end of the spindle. Rotate the valve handle counter clockwise to the maximum desired hot water temperature. Position the TLS plate so it contacts the TLS ring lug on the top of the valve’s cartridge and therefore restricts the counter clockwise rotation of the handle. Handle can be moved slightly, so TLS plate slips into place. Slip the retaining o-ring back into the groove of the spindle. Turn off the valve and remove the handle.

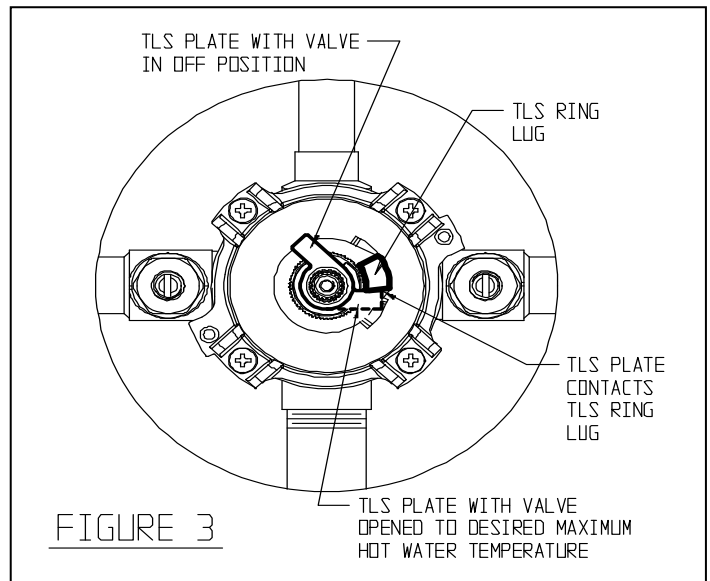
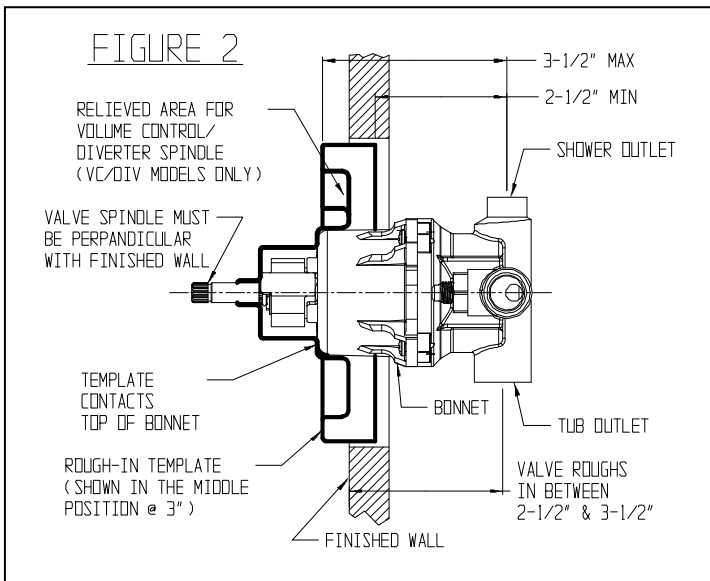

- 6) **Note-** For valve with built-in volume control/diverter feature, make sure the brass “VC/DIV” spindle is in the center position (spindle flats in the vertical position).

Slip the trim sleeve onto the spindle and valve. Make sure the sleeve legs are position between the ribs of the black bonnet. Apply clear silicone sealant to the backside outer flat surface of the wall plate. **Basic Valve-** Position the wall plate so that the 3/8 diameter hole is in the 12 o’clock position. Carefully slip the wall plate onto the trim sleeve. **Valve w/VC/DIV-** Position the wall plate and slide “VC/DIV” spindle tube onto the “VC/DIV” spindle of the valve. Carefully slip the wall plate onto the trim sleeve. Properly position against the finished wall. Fasten the wall plate to the valve using the valve using the (2) long wall plate screws. Make sure the wall plate hole is centered with the trim sleeve. **Do not over tighten the wall plate screws.** Wipe off any excess sealant from around the outer edge of the wall plate. Remove clear protective sheet from top of index plate (If applicable). Slip the index plate over the trim sleeve and position the small hole in the index plate onto the wall plate index pin. Holding the index plate in position, slip the index retaining ring over the trim sleeve and insert the tabs (2) of the ring into the wall

plate and index cut outs. With your fingers, firmly push and rotate the ring clockwise to lock into place. Properly position the handle onto the valve spindle and screw into place. Push index button into the handle.

### **BACK-TO-BACK INSTALLATION**

On this type of installation, the thermostatic/pressure balancing cartridge must be rotated 180° on the valve on which the hot & cold inlets are reversed. Refer to Figure #4 on this page for the proper positioning of the cartridge.

- 1) Make sure the hot & cold water supply stops at the valve, are shut OFF. With the valve in the OFF position, remove the retaining o-ring and TLS plate from the valve spindle. Remove the TLS ring from the valve cartridge. Remove the (4) valve bonnet screws and carefully remove the bonnet. The cartridge may come out with the bonnet. Remove the cartridge from the valve body by pulling on the valve spindle of the cartridge. Make sure the lower rubber quad rings (2) are properly installed in bottom of the cartridge and not in the valve body.
- 2) Reposition the thermostatic/pressure balancing cartridge per the Figure #4 below. Push cartridge into valve body.
- 3) Make sure the large bonnet o-ring seal is installed and seated properly in the valve body. Reassemble the valve bonnet, making sure the "UP" on the bonnet is in the up position. Tighten the (4) bonnet screws. Reassemble the TLS ring onto the cartridge, so that the ring's lower lug (with hole) is positioned between the bonnet lugs (2).

**Important- Adjust the valve's maximum hot water temperature to the recommended setting of 110° F.** See Step #5 of the installation instructions for the TLS adjustment instructions and Step #6 for the trim assembly instructions.

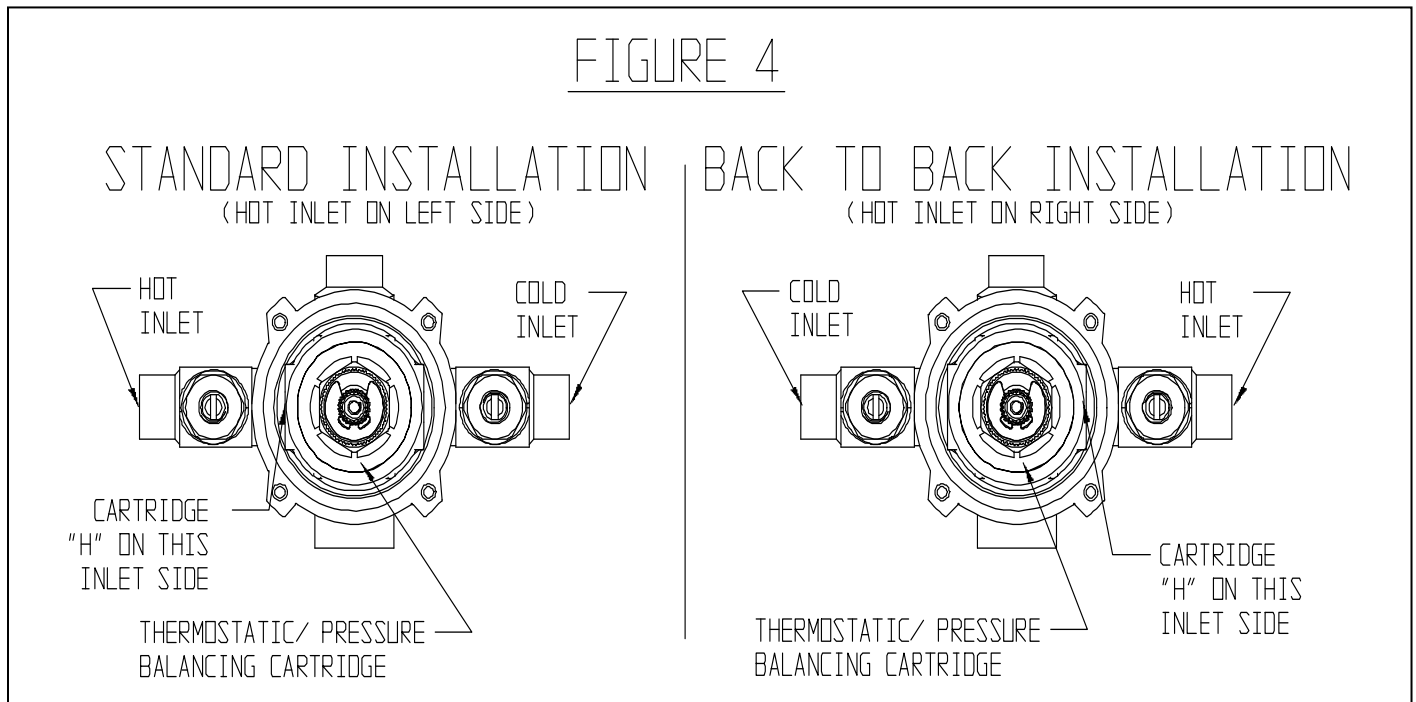

### **OPERATION INSTRUCTIONS**

**Important-** Both hot and cold water supplies & integral stops must be FULL on for the valve to operate properly.

Rotate the valve handle counter clockwise to the desired temperature. To shut the valve OFF, rotate the handle clockwise. Volume control/diverter models have an additional lever handle located at the top of the wall plate. The center position (12 o'clock) turns both the shower and tub discharge off. Clockwise rotation of this handle turns the shower discharge on and controls the discharge volume from the shower outlet of the valve. Counter clockwise rotation of this handle turns the tub discharge on and controls the discharge volume from the tub outlet of the valve. On volume control/diverter model, make sure the main valve handle is turned to the OFF position when the shower/bath is not in use.

## **MAINTENANCE** (CARE and CLEANING)

The Speakman Sentinel Pro thermostatic/pressure balancing shower /bath valve should provide years of reliable service. This type of valve must be cleaned and maintained on a regular basis. Periodic maintenance should be performed at least every 12 months or after any changes have been made to the building's plumbing system. This maintenance should include removing and cleaning the spring check stop components. Make sure the stop poppet in each stop moves freely. Valves that are installed outdoors should be winterized by removing all of the internal parts and removing any standing water from the valve. Quarterly the maximum hot temperature setting (TLS) should be checked (See Step #5 of the installation instructions). For servicing the valve, see the instructions below. The gleaming finish of your SPEAKMAN Sentinel Pro valve can be cleaned by using mild soap and warm water. Dry immediately with a soft, clean cloth for best results.

## **SERVICE INSTRUCTIONS**

**Caution- Any repair or servicing of the valve may affect the maximum hot temperature setting of the valve. After working on the valve, make sure the maximum hot water temperature is set to the recommended setting of 110° F maximum.**

- 1) **T/P Cartridge Removal**- Shut off the hot & cold water supply integral stops at the valve. Remove handle index button & handle. Remove index retaining ring & index. Remove wall plate screws (2) & wall plate. Remove the trim sleeve.
- 2) With the valve in the OFF position, remove the retaining o-ring and TLS plate from the valve spindle. Remove the TLS ring from the valve cartridge. Remove the (4) valve bonnet screws and carefully remove the bonnet. The cartridge may come out with the bonnet.
- 3) If necessary remove the cartridge from the valve body by pulling on the valve spindle of the cartridge. Make sure the lower rubber quad rings (2) are installed in the bottom of the cartridge and not in the valve body.
- 4) Replace the necessary parts with new parts. When replacing the T/P cartridge, make sure that the rubber quad-rings (2) are properly installed in the recesses on the bottom of the cartridge. These quad-rings seal over the hot & cold inlet holes inside the body. When replacing the cartridge, refer to Figure #4 for proper positioning of cartridge in the valve body.
- 5) Make sure the large bonnet o-ring seal is installed and seated properly in the valve body. Reassemble the valve bonnet, making sure the "UP" on the bonnet is in the up position. Tighten the (4) bonnet screws. Reassemble the TLS ring onto the cartridge, so that the ring's lower lug (with hole) is positioned between the bonnet lugs (2).  
**Important- Adjust the valve's maximum hot water temperature to the recommended setting of 110° F.** See Step #5 of the installation instructions for the TLS adjustment instructions.
- 6) Turn ON the hot & cold water supply integral stops. Check valve for leaks.
- 7) Reassemble the trim parts, reversing the above procedure (Also see Step #6 of the installation instructions).

- 1) **Spring Check Stop Parts Removal**- Shut off hot and cold water supply valves to the integral stops of the valve. Remove handle index button & handle. Remove index retaining ring & index. Remove wall plate screws (2) & wall plate.
- 2) CLOSE integral stops by turning the stop spindles clockwise. Unscrew the stop's retaining nut with wrench. Carefully remove the retaining nut w/spindle, spring, and poppet assembly. Clean and/or replace the necessary parts. Reassemble the parts, reversing the above procedure. Repeat procedure on the other stop.
- 3) OPEN the integral stops by turning the stop spindles counter clockwise. Turn on the hot and cold water supply valves. Check for leaks.
- 4) Reassemble the trim parts, reversing the above procedure (Also see Step #6 of the installation instructions).

## ROUGH-IN DIAGRAM

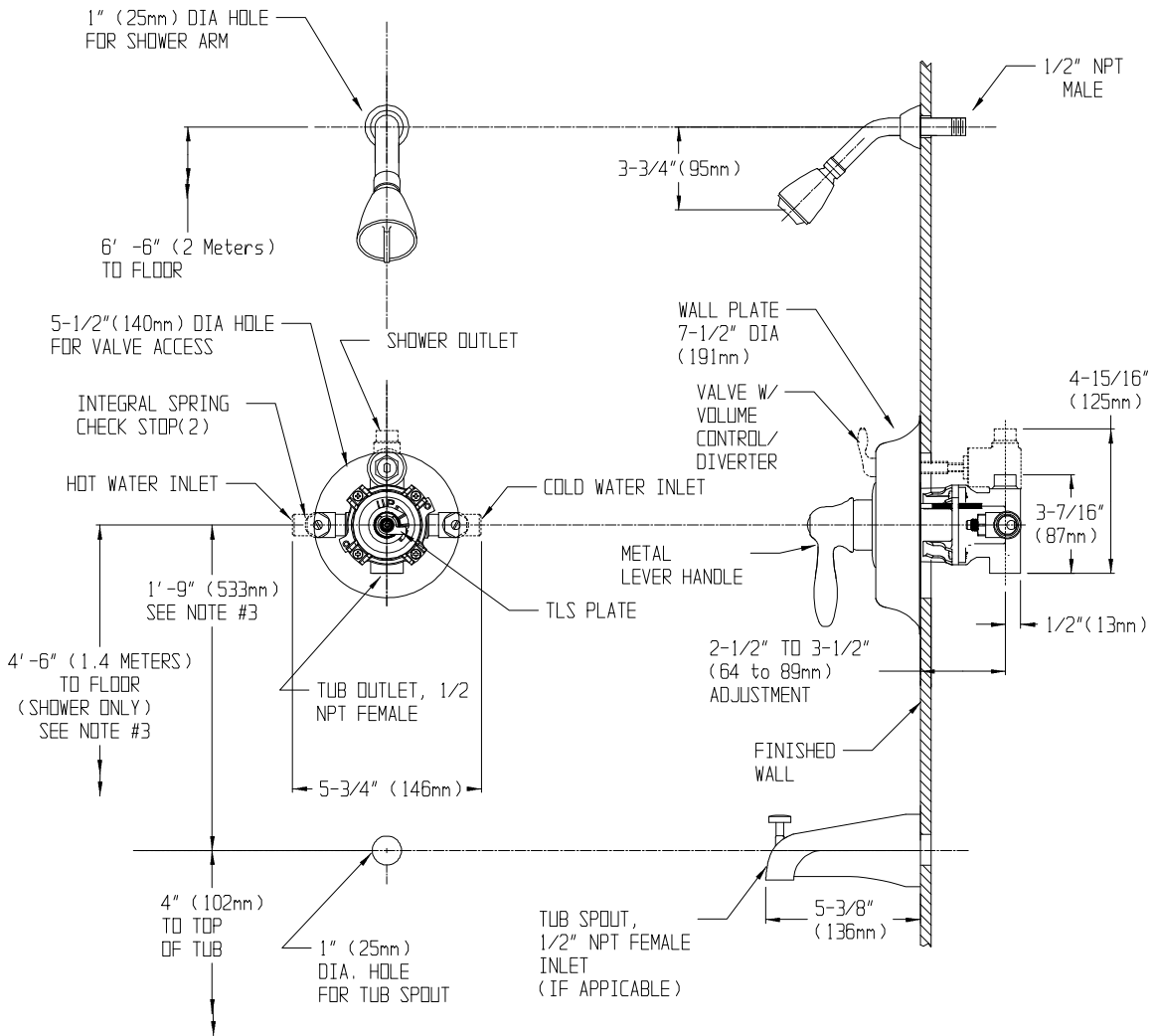

**NOTES:**

1. ALL DIMENSIONS ARE IN INCHES (MILLIMETERS) UNLESS OTHERWISE SPECIFIED AND ARE SUBJECT TO CHANGE WITHOUT NOTICE.
2. UNLESS OTHERWISE SPECIFIED ALL INLETS AND OUTLETS ARE 1/2" FEMALE COPPER SWEAT.
3. FOR ADA MOUNTING LOCATIONS CONSULT ADAAG, ANSI A117.1, OR STATE REGULATIONS.

### REPAIR / REPLACEMENT PARTS

ITEM NUMBER	PART OR GROUP NUMBER	DESCRIPTION
1	RPG49-0126	BONNET O-RING
2	RPG05-0718	BONNET, SCREWS (4), & O-RING REPAIR GROUP
3	RPG05-0860	T/P REPAIR CARTRIDGE (COMPLETE w/SPINDLE)
4	RPG49-0006	LOWER QUAD RINGS (2) FOR T/P CARTRIDGE
5	RPG05-0847	VOLUME CONTROL/DIVERTER CERAMIC REPAIR CARTRIDGE
6	RPG05-0862	CHECK STOP REPAIR GROUP (REPAIRS BOTH STOPS)

## SPEAKMAN®

PO Box 191 Wilmington, DE 19899 Phone: 800-537-2107 Fax: 800-977-2747  
 Visit us on the web at [www.speakmancompany.com](http://www.speakmancompany.com)

# SPEAKMAN COMPANY

## ROUGH-IN DIAGRAM FOR HAND SHOWER COMBINATIONS (WITH TRANSFER VALVE & SHOWERHEAD)

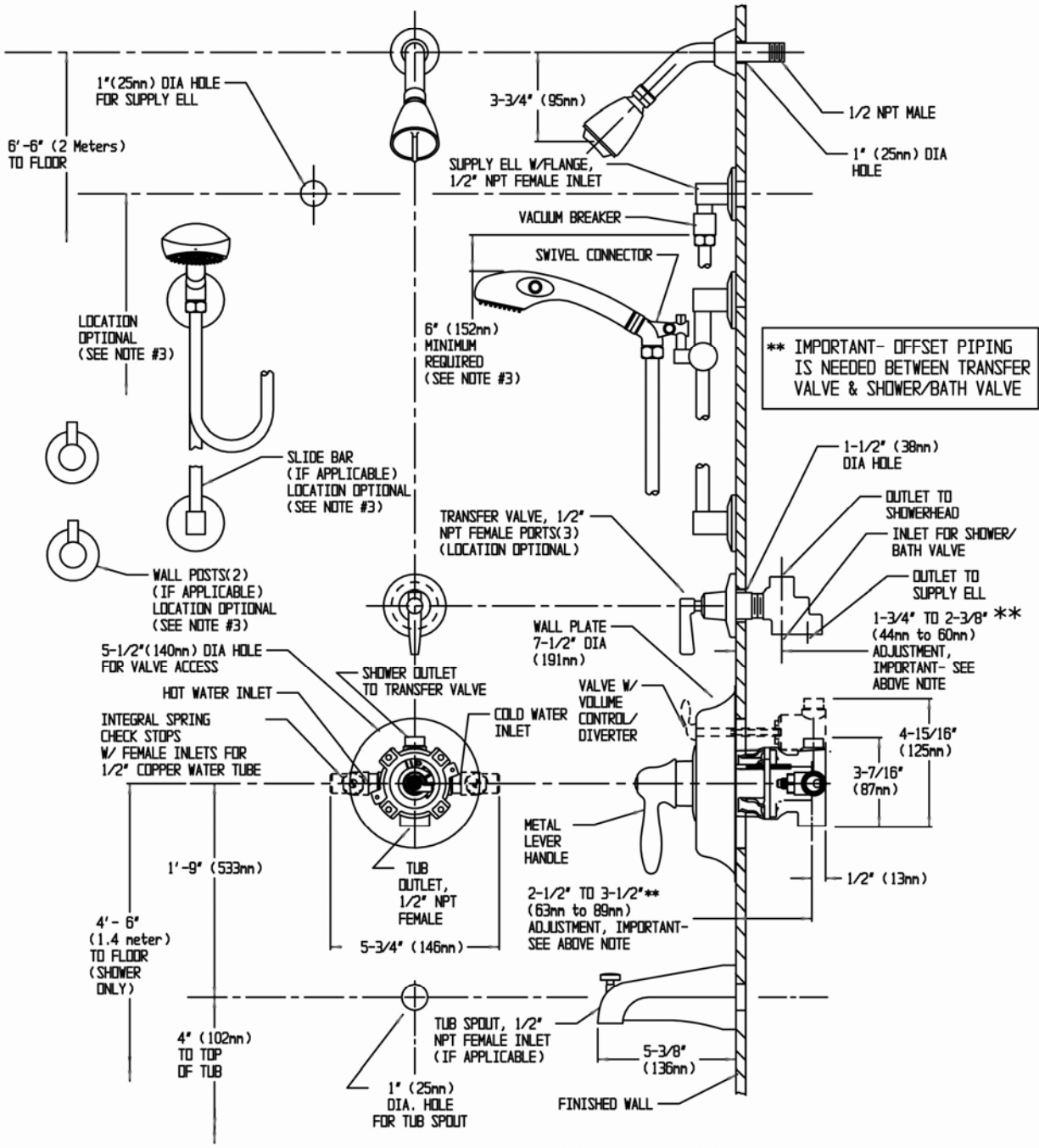

- NOTES:
1. ALL DIMENSIONS ARE IN INCHES (MILLIMETERS) UNLESS OTHERWISE SPECIFIED AND ARE SUBJECT TO CHANGE WITHOUT NOTICE.
  2. UNLESS OTHERWISE SPECIFIED ALL INLETS AND OUTLETS ARE 1/2" FEMALE COPPER SWEAT.
  3. THE LOCATIONS OF THE SLIDE BAR OR WALL POSTS(2) AND SUPPLY ELL ARE OPTIONAL, BUT RESTRICTED BY THE 69" HOSE LENGTH RUNNING FROM THE SUPPLY ELL CONNECTION TO THE HAND SHOWER AND THE 6" MINIMUM REQUIREMENT BETWEEN THE IN-LINE VACUUM BREAKER AND TOP OF THE HAND SHOWER (HAND SHOWER ADJUSTED TO HIGHEST POSITION).

**SPEAKMAN®**

PO Box 191 Wilmington, DE 19899 Phone: 800-537-2107 Fax: 800-977-2747  
 Visit us on the web at [www.speakmancompany.com](http://www.speakmancompany.com)

#92-3167