

SPEAKMAN COMPANY

SM- Regency/Royale Valve, Showerhead, Tub Spout, & Combo Series Installation, Maintenance & Operation Instructions

DESCRIPTION

Speakman Sentinel Mark II Regency/Royale concealed anti-scald balanced pressure shower /bath valve & combinations. Chrome plated brass wall plate (Regency). Chrome plated plastic wall plate (Royale). Chrome plated brass lever handle. Adjustable temperature limit stop. Brass body. Noryl® bonnet. Pressure balancing module. Ceramic temperature regulating module. Can be installed back to back. Roughing-in template. S-2270-AF COSMOPOLITAN® showerhead (If applicable), S-2280-AF Anystream wall mounted showerhead (If applicable), or VS-100 Handheld Shower (If applicable) with flow control device reduces flow to 2.5 GPM/9.46 LPM maximum to meet existing ASME A112.18.1/CSA B125.1 Standard. Chrome plate brass shower arm and wall flange (If applicable). Chrome plated tub spout (If applicable). Four port valve with ½” NPT female inlets and outlets. Meets ASSE 1016 Standard.

SPECIFICATIONS

SUPPLY: ½” NPT FEMALE (VALVE)

FLOW RATE: 2.5 GPM/9.46 LPM MAX. (SHOWERHEAD AND/OR HANDHELD SHOWER, IF APPLICABLE)

SHIPPING WEIGHT: 3.5 LBS (SM-3000)

OPTIONS

◇ 1 - S-2251 Showerhead	◇ 4 - S-2220-AF Showerhead	◇ AP - Anchor Plate (S-2280-AF Showerhead Only)
◇ 2 - S-2252-AF Showerhead	◇ 6 - S-2288-AF Showerhead	◇ BJ - Ball Joint (S-2280-AF Showerhead Only)
◇ 2VR - S-2252-AF Vandal Resistant Showerhead	◇ PC – Polish Chrome Handheld Shower (Combo w/VS-100 Only)	◇ VH- White Vinyl Hose (Combo w/Handheld Shower Only)
◇ 3 - S-2253-AF Showerhead	◇ 9 - S-2292-AF Showerhead	◇ LH - Less Showerhead
◇ 7 - S-2291-AF Showerhead	◇ SCS - Spring Check Stops	◇

INSTALLATION INSTRUCTIONS

Important- Read these instructions before installing the valve. Use the correct “Rough-in Diagram” for the unit that is being installed. Maximum water pressure: 125 PSI static; minimum water pressure: 20 PSI flowing; maximum supply temperature: 160° F; minimum supply temperature: 40° F. Use a suitable sealant on all threaded connections and when soldering, remove all internal parts prior to applying heat to the optional (SCS) stop bodies. The valve rough-in adjustments are 2-1/2” to 3-1/2” from the finished wall to the centerline of the hot & cold inlets of the valve body. On **diverter model valves**, do not substitute other outlet accessories for the tub spout. The diverter mechanism in the valve is so designed that it cannot be subject to any back pressure, other than imposed by a standard tub spout (1/2 copper or ½ NPT minimum spout inlet).

- 1) Referring to the correct “Rough-in Diagram” for the unit that is being installed (See the back page or the separate insert sheet), install the hot & cold supply lines for the valve, making sure they are on an accurate horizontal plane. Taking the valve assembly, making sure the “UP” on the valve bonnet is in the up position, connect the hot supply line to the left side of the valve & the cold supply line to the right (marked “BLUE”) side of the valve. Make sure the valve is straight, level, & positioned properly in the wall (See Figure 1). See Page 2 for “Back To Back” valve installation instructions.
- 2) Slip the rough-in template over the valve control spindle. If the opening in the wall is smaller than the outside diameter of the template, trace the outside diameter of the template, remove the template, and recut the opening in the wall. Slip the template onto the valve again until the template bottoms out on the top of the valve bonnet (See Figure 2). Note- When installing a valve with the built-in diverter, make sure the template is positioned so the plastic diverter spindle is in the relieved area of the template. The finished wall should fall between the minimum and maximum limits of the template if the valve has been installed properly. Leave the template in place if the finished wall has to be installed. The template will insure the proper size opening for repair accessibility, as well as protect the valve from damage during the finished wall installation.

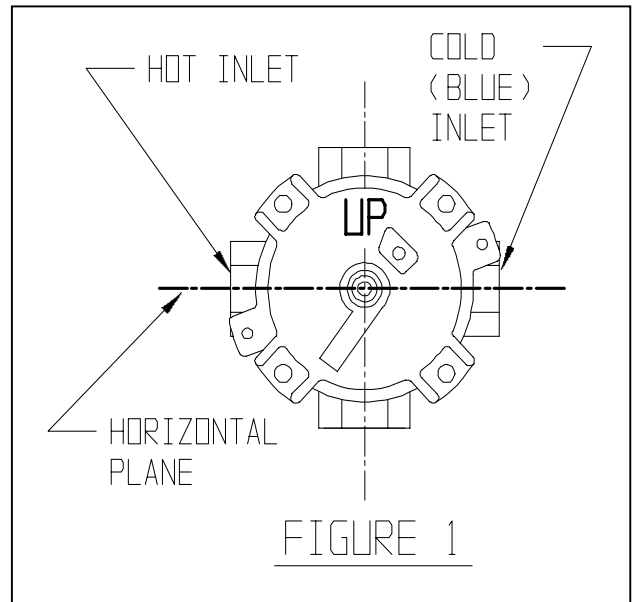

- 3) Install the rough piping and transfer valve (If applicable) to the shower and/or tub outlets of the valve. If the installation is only using one outlet, be sure to plug the other outlet with the provided pipe plug. If applicable, construct the finished wall.
- 4) With the necessary opening(s) in the finished wall, assemble the accessory(s) to the rough piping (**Important-** See separate “Accessory Installation Instructions” supplied with some of the accessories). With the rough-in template removed & the valve turned OFF, turn both the hot & cold water supplies ON. Using the handle, operate the valve checking all the connections for leaks.
- 5) To limit the maximum hot water temperature the valve delivers, adjust the valve’s temperature limit stop (TLS) plate (See Figure 3). Slip the retaining o-ring and the TLS plate towards the end of the spindle. Rotate the valve handle clockwise to the maximum desired hot water temperature. Position the TLS plate so it contacts the lug on the valve bonnet and therefore restricts the clockwise rotation of the handle. Slip the retaining o-ring back into the groove of the spindle. Turn off the valve and remove the handle.

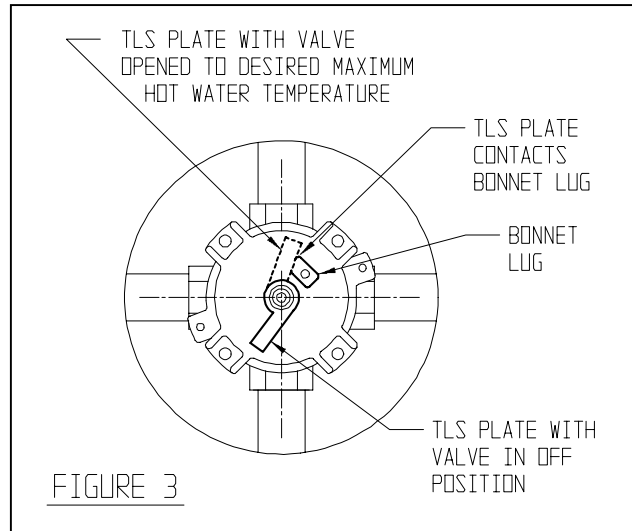
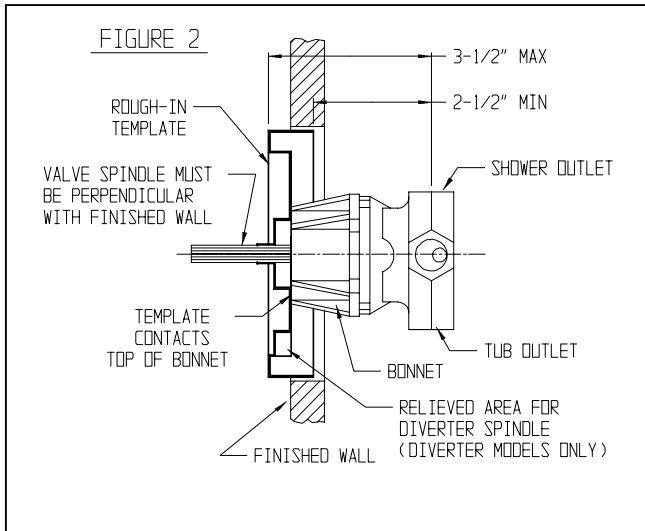

Note- For shower/tub valve with built-in diverter, make sure the plastic diverter spindle is in the “UP” position (spindle is marked “UP”).

- 6) Slip the trim sleeve onto the spindle and valve. **Important-** Rotate the sleeve so that the lug on the valve bonnet is in the pie shaped opening of the sleeve (See Figure 4). Apply clear silicone sealant to the back side outer flat surface of the wall plate. For valve with a brass wall plate, make sure the threaded boss in the wall plate is below the center hole. Carefully slip the wall plate onto the trim sleeve, volume control spindle (If applicable) or diverter spindle (If applicable), and properly position against the finished wall. Fasten the wall plate to the valve using the (2) long wall plate screws. Do not over tighten the wall plate screws. Wipe off any excess sealant from around the outer edge of the wall plate. If applicable, remove clear protective sheet from top of index plate. Slip the index plate over the trim sleeve and fasten to the wall plate with the screw & flat washer provided. Properly position the handle onto the valve spindle and screw into place. Push index button into the handle.

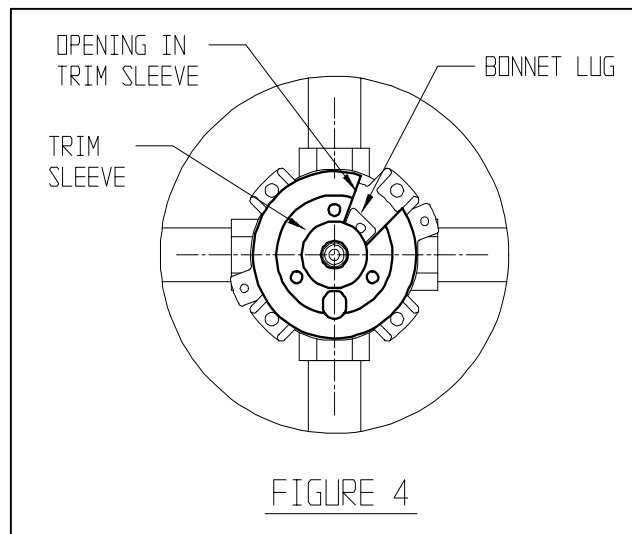

BACK TO BACK INSTALLATION

On this type of installation, the regulating module must be rotated 180° on the valve on which the hot & cold inlets are reversed. Refer to Figure 5 on the next page for the proper positioning of the regulating module.

- 1) Make sure the hot & cold water supplier are shut OFF. With the valve in the OFF position, remove the (4) valve bonnet screws. Carefully remove the bonnet, making sure the regulating module does not fall out, onto the floor. The regulating module sits on top of the balancing module, but may come off with the bonnet. If necessary remove the regulating module.
- 2) Reposition the regulating module per the Figure 5 drawing. Rotate the module counter clockwise until the module stops come in contact with the balancing module stop posts.
- 3) Make sure the large bonnet o-ring seal is installed and seated properly in the valve body. Reassemble the valve bonnet, making sure the “UP” on the bonnet is in the up position. Tighten the (4) bonnet screws.

FIGURE 5

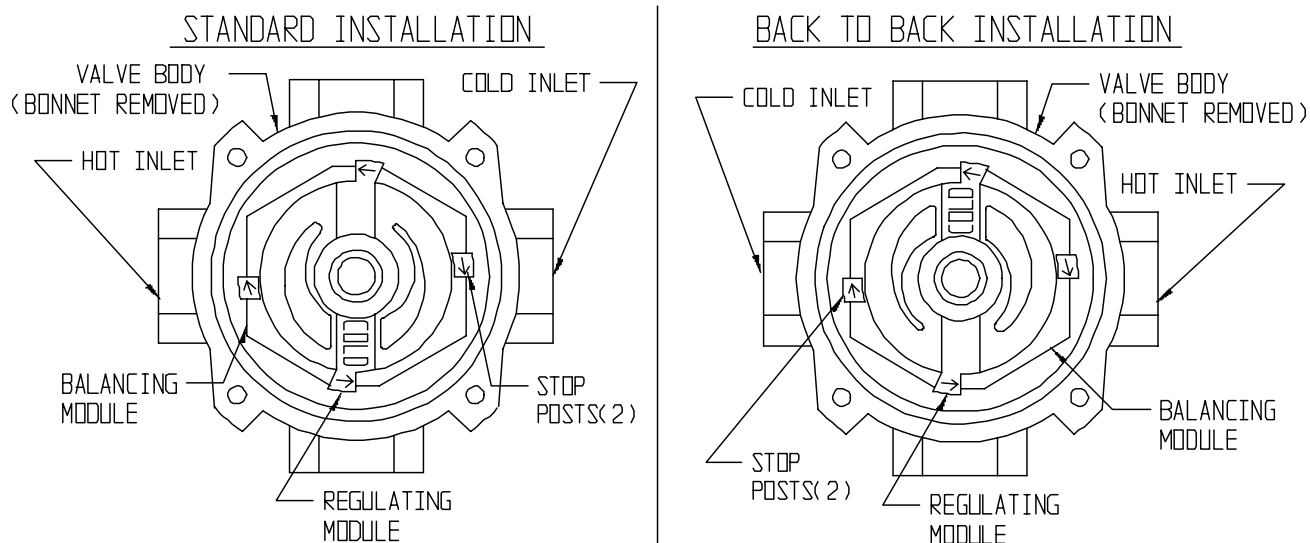

INSTRUCTIONS: PER THE INSTALLATION, POSITION REGULATING MODULE ON TOP OF BALANCING MODULE AS SHOWN. ROTATE REGULATING MODULE COUNTER CLOCKWISE UNTIL IT CONTACTS THE BALANCING MODULE STOP POSTS ("OFF" POSITION).

OPERATION INSTRUCTIONS

Important- Both hot and cold water supplies must be FULL on for the valve to operate properly.

Rotate the valve handle clockwise to the desired temperature. To shut the valve OFF, rotate the handle counter clockwise. Volume control models have an additional lever handle located at the top of the wall plate. Rotation of this handle controls the discharge volume from the shower outlet of the valve. Diverter models have a similar handle located at the bottom of the wall plate. Rotation of this handle diverts the discharge flow from the tub spout to the shower outlet or from the shower outlet to the tub spout.

MAINTENANCE (CARE and CLEANING)

The shower/bath valve is washerless and requires no routine maintenance. The valve uses a ceramic regulating module and a balancing module. There are no seat washers or packing to repair. For servicing the valve modules, see the instructions below. The gleaming finish of your SPEAKMAN Regency/Royale valve can be cleaned by using mild soap and warm water. Dry immediately with a soft, clean cloth for best results.

SERVICE INSTRUCTIONS

- 1) Shut off the hot & cold water supplies to the valve. Remove handle index button & handle. Remove index screw & index (If applicable). Remove wall plate screws (2) & wall plate.
- 2) With the valve in the OFF position, remove the (4) valve bonnet screws. Carefully remove the bonnet, making sure the regulating module does not fall out, onto the floor. The regulating module sits on top of the balancing module, but may come off with the bonnet. If necessary remove the regulating module.
- 3) If necessary remove the balancing module from the valve body. If it does not easily pull out, take a pair of pliers and carefully grab the module and pull out of body.
- 4) Replace the necessary parts with new parts. When replacing the balancing module, make sure that the quad-rings (2) are properly installed in the recesses on the bottom of the module. These quad-rings seal over the hot & cold inlet holes inside the body. When replacing the regulating module, refer to Figure 5 for proper positioning of module. Rotate the regulating module counter clockwise until the module stops come in contact with the balancing module stop posts.
- 5) Make sure the large bonnet o-ring seal is installed and seated properly in the valve body. Reassemble the valve bonnet, making sure the "UP" on the bonnet is in the up position. Tighten the (4) bonnet screws. Turn ON the hot & cold water supplies. Check valve for leaks. If necessary, adjust the TLS plate (See Step 5 of the installation instructions).
- 6) Reassemble the trim parts, reversing the above procedure.

ROUGH-IN DIAGRAM

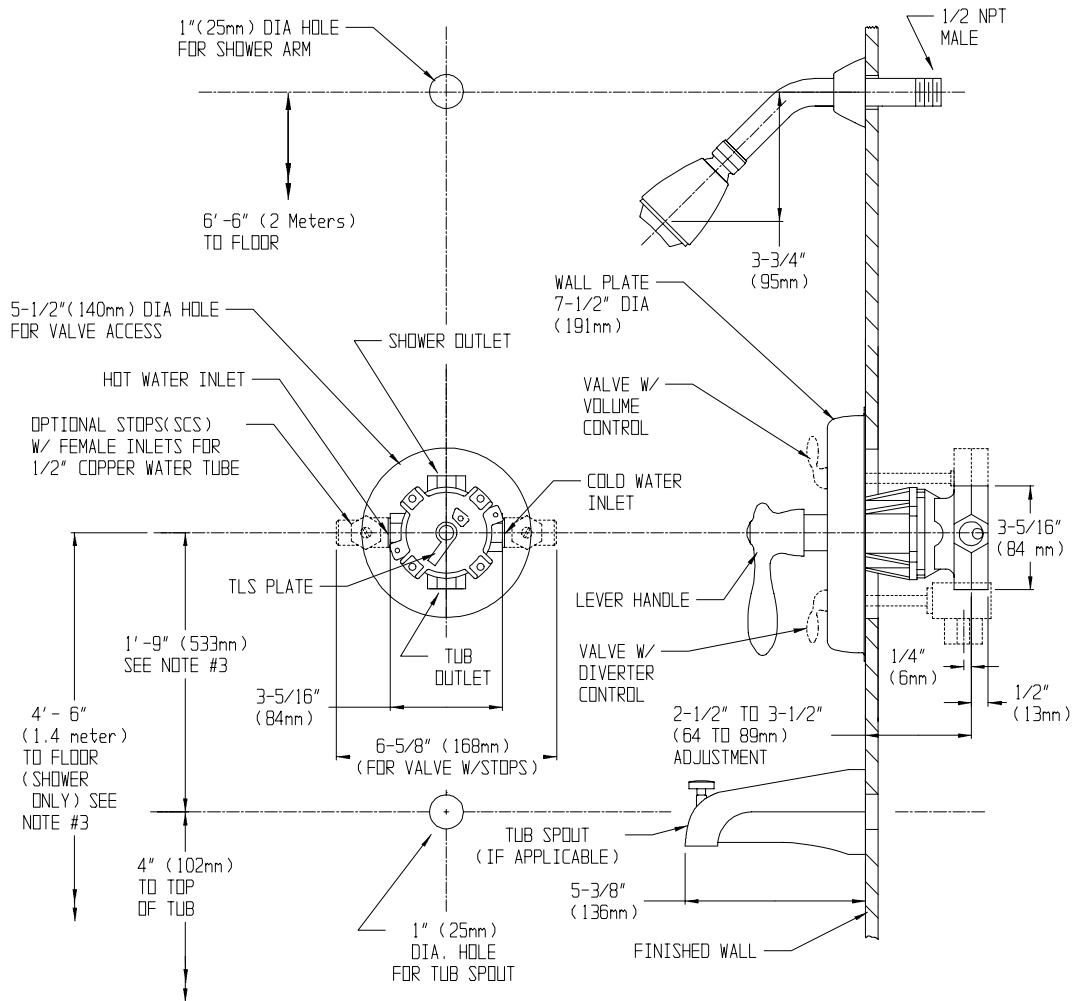

NOTES:

1. ALL DIMENSIONS ARE IN INCHES (MILLIMETERS) UNLESS OTHERWISE SPECIFIED AND ARE SUBJECT TO CHANGE WITHOUT NOTICE.
2. UNLESS OTHERWISE SPECIFIED ALL INLETS AND OUTLETS ARE 1/2" NPT FEMALE.
3. FOR ADA MOUNTING LOCATIONS CONSULT ADAAG, ANSI A117.1, OR STATE REGULATIONS.

REPAIR / REPLACEMENT PARTS

ITEM NUMBER	PART OR GROUP NUMBER	DESCRIPTION
1	RPG49-0126	BONNET O-RING
2	RPG05-0718	BONNET, SCREWS (4), & O-RING REPAIR GROUP
3	RPG03-0259-RCP	STANDARD VALVE SPINDLE, WASHERS (2), & O-RINGS (2) REPAIR GROUP
4	RPG03-0365-RCP	1" LONGER VALVE SPINDLE, WASHERS (2), & O-RINGS (2) REPAIR GROUP
5	RPG03-0366-RCP	1-1/2" LONGER VALVE SPINDLE, WASHERS (2), & O-RINGS (2) REPAIR GROUP
6	RPG49-0076	SPINDLE O-RING REPAIR GROUP (4 O-RINGS PER BAG)
7	G05-0412-MO	REGULATING MODULE REPAIR GROUP (COMPLETE MODULE)
8	G05-0413	BALANCING MODULE REPAIR GROUP (COMPLETE MODULE)
9	RPG49-0127	QUAD RINGS (2) FOR BALANCING MODULE
10	RPG03-0372	VOLUME CONTROL SPINDLE REPAIR GROUP (SPINDLE & O-RING)
11	RPG03-0362-MO	DIVERTER SPINDLE REPAIR GROUP (SPINDLE & O-RING)

SPEAKMAN®

PO Box 191 Wilmington, DE 19899

Phone: 800-537-2107 Fax: 800-977-2747

Visit us on the web at www.speakmancompany.com