

SPEAKMAN®

SE-505

EYESAVER® EYEWASH



DESCRIPTION

The SE-505 wall mounted Eyesaver® eyewash station offers twin aerated sprays for gentle yet thorough rinsing of the eyes and face. The unit features a rectangular stainless steel bowl and unique panic bar activation system.

SPECIFICATIONS

Bowl: 300 series stainless steel

Spray Heads: (2) aerated yellow nylon spray outlets

Valve: ½" NPT female brass, chrome-plated

Activator: Stainless steel trigger bar

Inlet: ½" NPT female

Performance: 3.0 gpm @ 30 psi

Compliance: ANSI Z358.1

Universal Emergency Sign Included

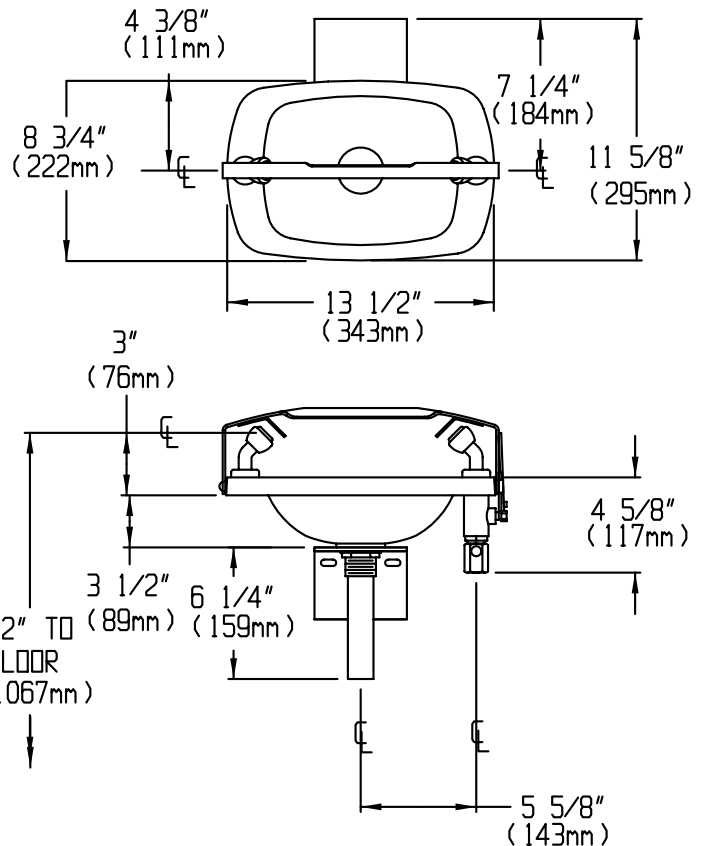

OPTIONS

- FLW Flow switch
- FPV Freeze protection valve
- HFO Hand/Foot operation
- HS Hand-held spray
- ILS In-line strainer
- PT P-trap
- SPV Scald protection valve
- SSBV Stainless steel ball valve

Job Name _____
Location _____
Architect/Engineer _____
Sales Representative _____
Wholesaler _____
Date _____ Model # _____