

# SPEAKMAN ALEXANDRIA™

## Single Lever Faucet SB-1020

SPECIFICATION



### FEATURES:

- Lead-free brass construction
- Ceramic cartridge
- 1.5 gpm flow rate
- Traditional style
- Includes drain assembly

### COMPLIANCE:

- Certified to ASME A112.18.1/CSA B125.1, NSF 61 and WaterSense standards
- CA AB 1953 certified



### AVAILABLE FINISHES:

ADD SUFFIX TO MODEL #

- Polished Chrome (standard)
- Brushed Nickel □ -BN

### WARRANTY:

- 1 year limited

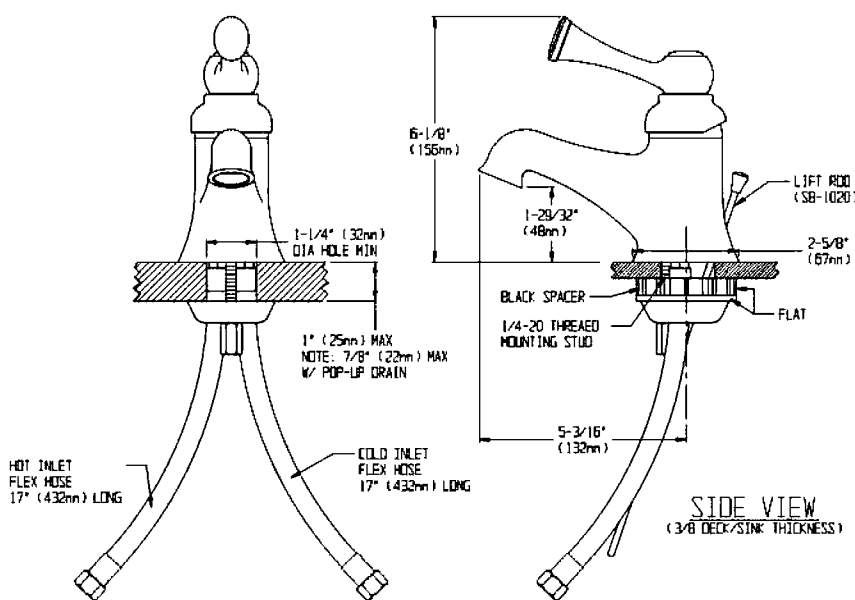

NOTE: 1. All dimensions are in inches (millimeters) unless otherwise specified and are subject to change without notice. 2. Flex hoses have 3/8 compression female threaded connections. 3. Use black spacer for deck/sink thickness of 3/8 and under (see side view above).

THIS SPACE FOR ARCHITECT/ENGINEER APPROVAL.

# SPEAKMAN®

400 ANCHOR MILL ROAD | NEW CASTLE, DE 19720  
 P: 800-537-2107 | F: 800-977-2747  
 WWW.SPEAKMANCOMPANY.COM

REVISION DATE: FEB. 2013

Management Systems  
 Registered to ISO 9001