

ZW5202 Modular Kennel Cages Assembly Instructions Small and Medium

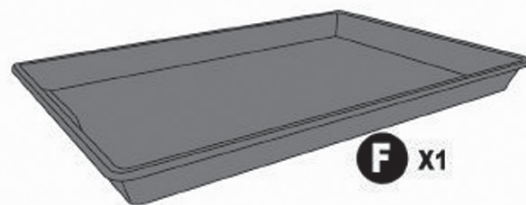

- Parts List**
- (A) Side Panels (2)
 - (B) Back Panel (1)
 - (C) Top/Bottom Panels (2)
 - (D) Front Door (1)
 - (E) Allen Wrenches (2)
 - (F) Tray (1)
 - (G) Floor Grate (1)
 - (H) and (I) Front Door Fasteners (8)
 - (J) Screw for Modular Kennels (S) (34)
 - Screws for Modular Kennels (M) (44)

TIP: For each step, do not completely tighten screws and bolts until all have been fitted to the structure.

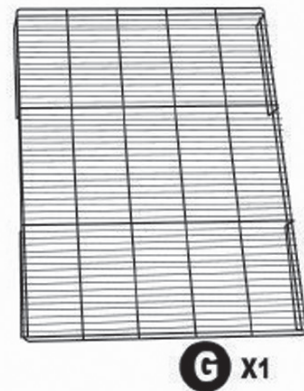
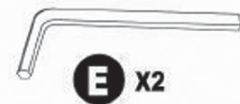
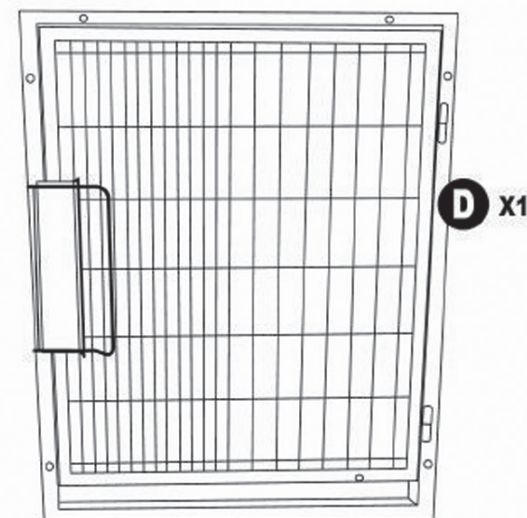
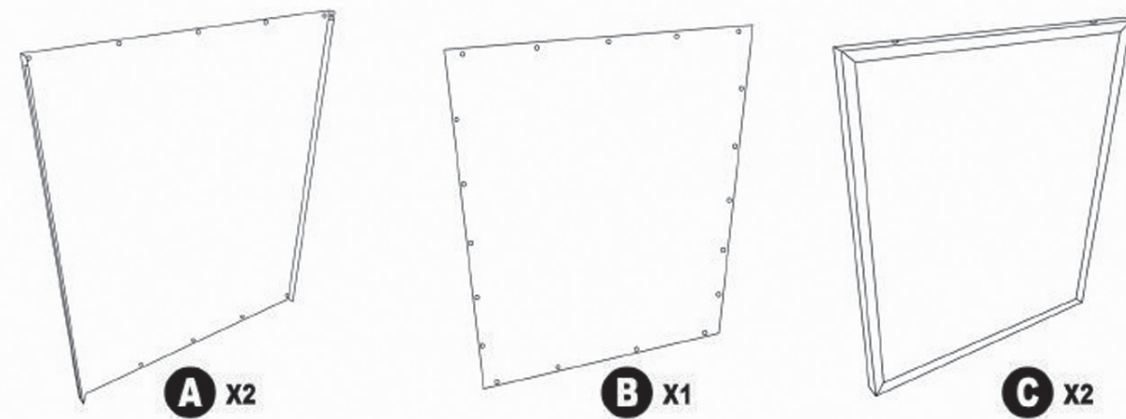
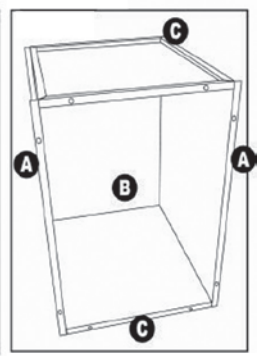
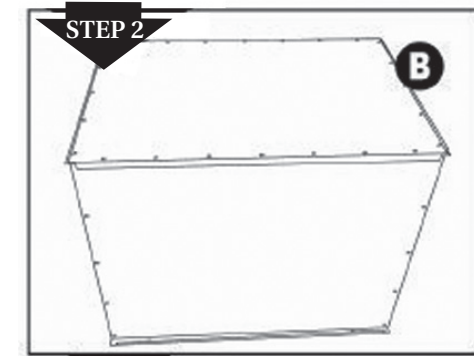
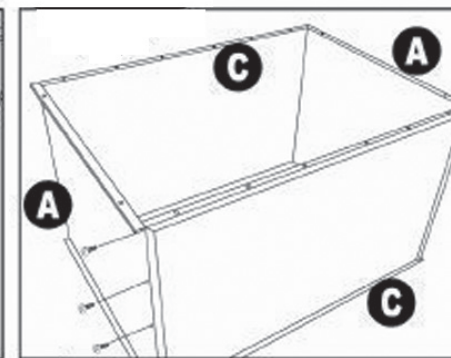
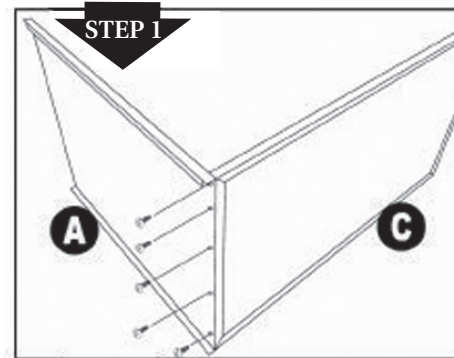

1. Connect Side Panels (A) to Top and Bottom Panels (C) using Screws (J). Note: the panel sides with the metal edging should all be facing out. The flat sides should face in.

2. Connect the Back Panel (B) to the assembled panels using Screws (J).

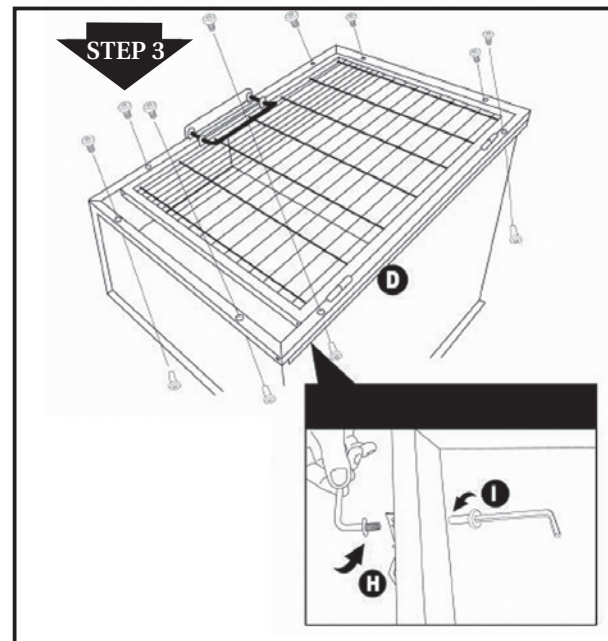

3. Attach the Front Panel (D) to the front of the structure using Bolts (H and I). The smaller (H) bolts should connect from the front, the Larger (I) bolts should connect from the back. Use the two Allen Wrenches (E) as shown to secure bolts during assembly.

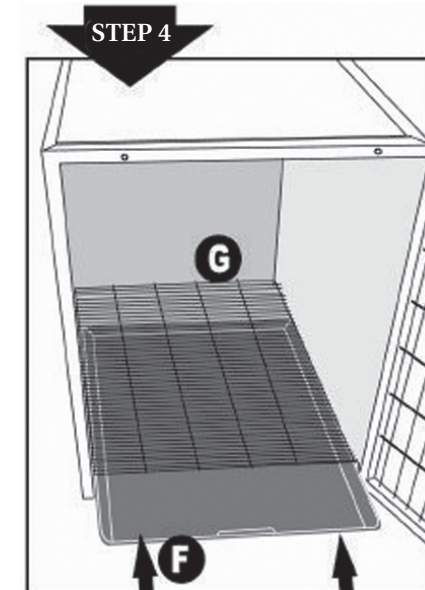

4. Slide the Floor Tray (F) and the Floor Grate (G) into the structure.

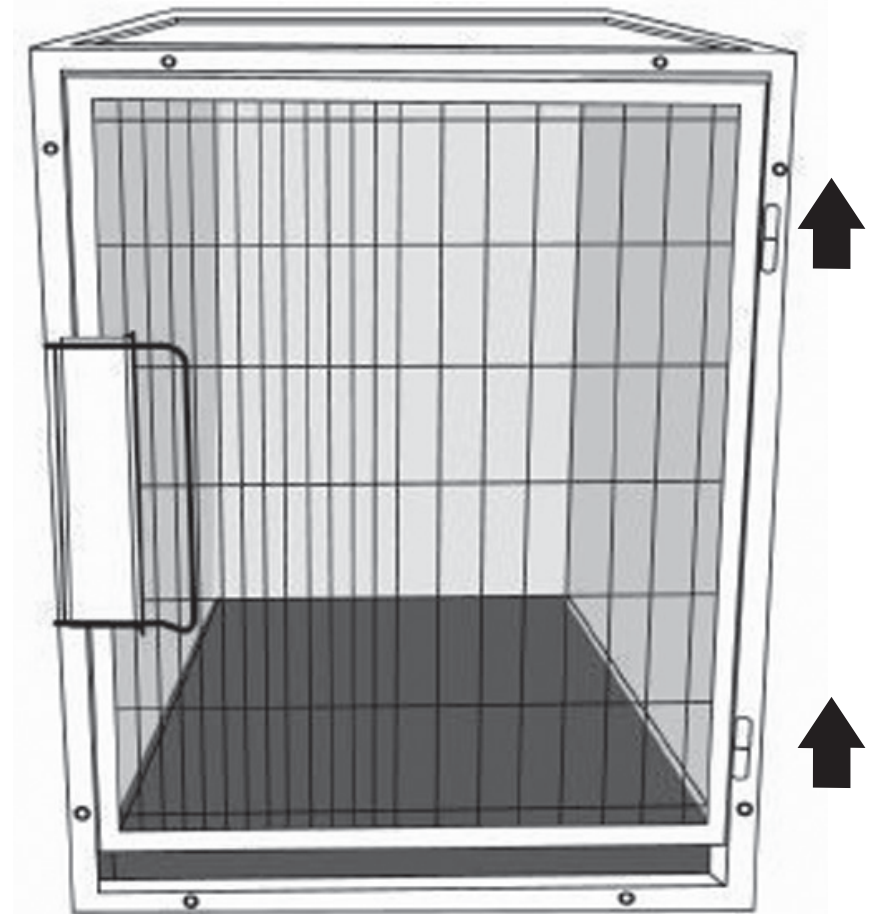

5. The doors can be taken off the hinges by lifting them straight up and off.