



ASSEMBLY GUIDE

Pocono Deep Seating Love Seat & Arm Chair

DSLS2 - DSSS2 [10.11.12]



TOOLS

- 7/16" Wrench
(Socket wrench recommended)
- Screwdriver/Square bit #1
(Power screwdriver/Square bit #1 recommended)
- Hammer

COMPONENTS

Part	Description	Qty
(A)	Arm Rests with leg assembly	2
(B)	Seat Base	1
(C)	Seat Back	1
(D)	Seat Braces	2
(E)	Carriage bolts	8
(F)	Flange Nuts	8
(G)	3" Wood screws	6
(H)	2-1/4" Wood screws	2
	Square bit #1	1
Love Seat Only		
(I)	2-3/4" Wood screws	1

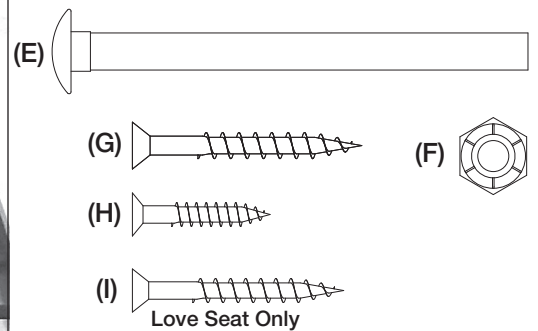
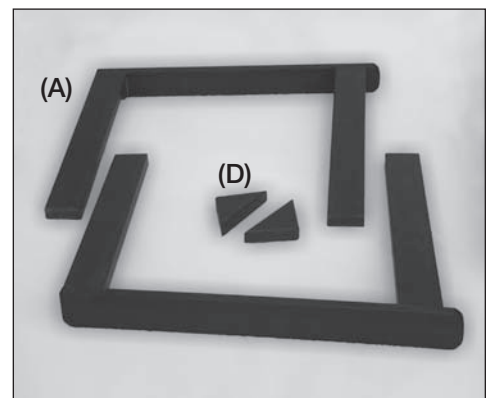
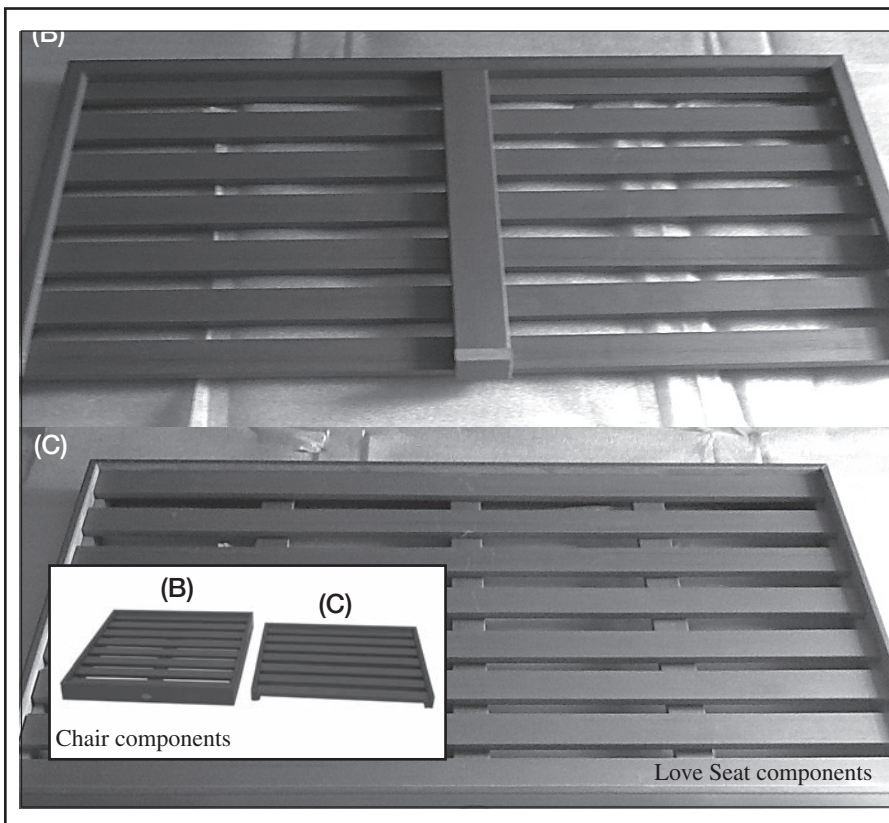

Before you start

This assembly can be done by one person alone, however it is much easier when two people work as a team.

STEP 1

Connect Arm Assembly to the Seat Base

Position and hold the Arm Rest (A) and Seat Base (B) together, and attach by inserting one Carriage Bolt (E) into the pre-drilled hole in the front and one in the back of the Seat Base as shown in Image #1. **Be certain the seat base is facing forward (*highwood*[®] badge is at front and right side up) and the left and right arms are on the correct side.**

Note: Holes are pre-drilled for the Carriage Bolt to pass through, but use a hammer to firmly tap the bolt end several times so that the square neck sinks into the *highwood*[®] material.

Attach Flange Nut (F) to the carriage bolt from the inside of seat base and tighten so that it further pulls the bolt neck into the material leaving just the dome flush with the surface.

Using two 3" Wood Screws (G) finish attaching the Arm Rest to the Seat Base by inserting the Wood Screws into the pilot holes in the front and back of the Seat Base as shown in Image # 2.

Repeat on other side.

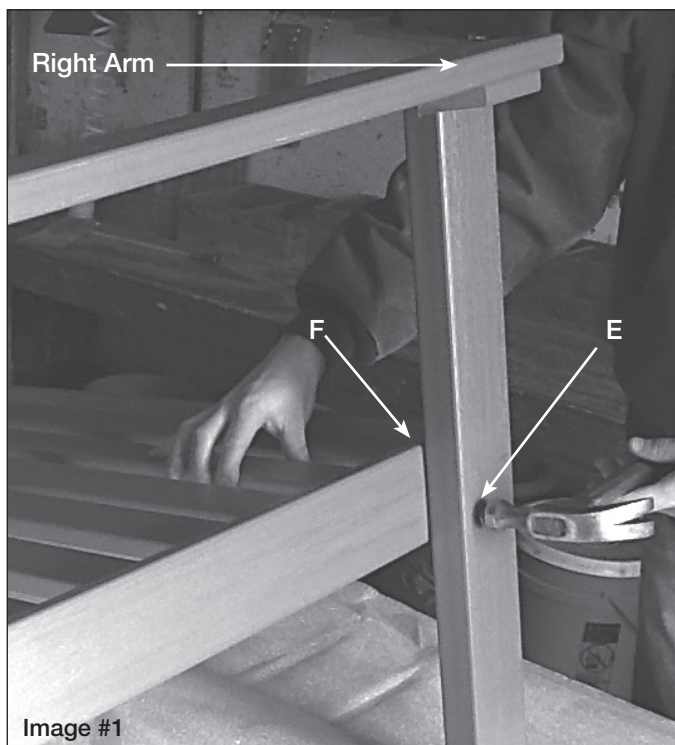

Care and Cleaning

Highwood products are ultra-low maintenance but for information on seasonal cleaning or to see a video that explains how to remove minor scratches visit <http://www.highwood-usa.com/care.html>

STEP 2

Attaching Seat Braces

With the chair flipped upside down, resting on the arm rests, position Seat Brace (D) under and at the front of the seat. Hold the seat brace and attach to the Leg using one 2-1/4" Wood Screw (H) and to the Seat Base using one 3" Wood Screw (G) in the pilot holes as shown in Image #3.

Repeat on other side.

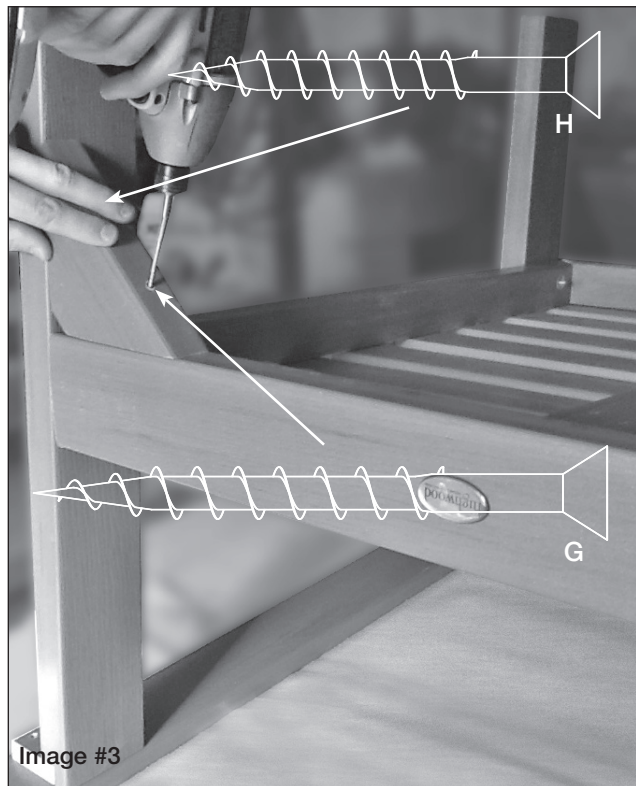

STEP 3

Connect Seat Back to Seat Base

Flip the chair back over, so it is right side up. Position and hold the Seat Back (C) and Seat Base (B) together, and attach by inserting two Carriage Bolts (E) into the pre-drilled holes as shown in Image #4.

Note: Holes are pre-drilled for the Carriage Bolt to pass through, but use a hammer to firmly tap the bolt end several times so that the square neck sinks into the *highwood*[®] material. See Image #4.

Attach Flange Nut (F) to the carriage bolt from the inside of chair back and tighten so that it further pulls the bolt neck into the material leaving just the dome flush with the surface.

Repeat on other side.

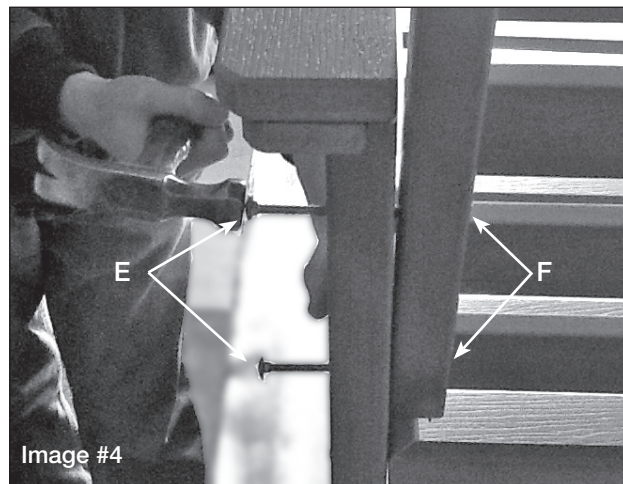

The Arm Chair assembly is complete.

STEP 4 LOVE SEAT ONLY

Secure the Love Seat Back center by inserting one 2-3/4" Wood Screw (I) into the pilot hole as shown in Image #5.





ENJOY YOUR HIGHWOOD FURNITURE!



Other Highwood items you may be interested in.



For information on Care and Cleaning your *highwood*[®] product visit www.highwood-usa.com/care.html

Visit our Website and Facebook page to see more *highwood*[®] products!

www.highwood-usa.com • www.facebook.com/highwoodUSA