

**Dayton® Double Bowl
Model D23317**

DAYTON

SPECIFICATIONS

GENERAL

Sink bowls are seamlessly drawn of heavy gauge, nickel bearing stainless steel. Self-rimming.

DESIGN FEATURES

Bowl Depths: 6" (Both Bowls).
 Coved Corners: Interior vertical and horizontal corners are rounded to a minimum of 2-3/4" radii.
 Finish: Exposed surfaces are polished to a satin finish.
 Underside: Fully undercoated to deaden sound.

OTHER

Drain Opening: 3-1/2".
 This sinks complies with ANSI Standard A112.19.3M.

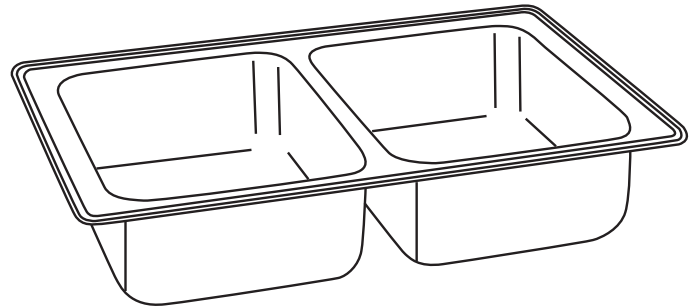

Model D23317

SINK DIMENSIONS (INCHES)*

Model Number	Overall		Inside Each Bowl			Cutout in Countertop (1 1/2" Radius Corners)		Number of 1 1/2" Dia. Faucet Holes	Ship. Wt. Lbs.
	L	W	L	W	D	L	W		
D23317	33	17	14	14	6	32 3/8	16 3/8	None	12

*Length is left to right. Width is front to back.

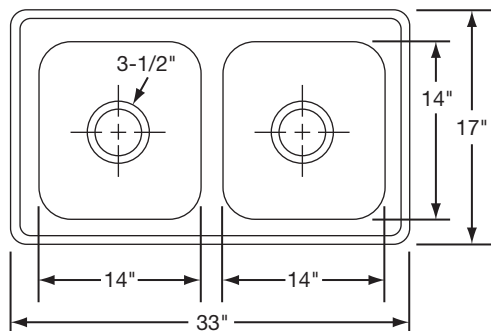

Model D23317 Illustrated

ALL DIMENSIONS IN INCHES, TO CONVERT TO MILLIMETERS MULTIPLY BY 25.4.

In keeping with our policy of continuing product improvement, Elkay reserves the right to change product specifications without notice.

This specification describes an Elkay product with design, quality and functional benefits to the user. When making a comparison of other producers' offerings, be certain these features are not overlooked.