

SPECIFICATIONS

GENERAL

Sink bowls seamlessly drawn of heavy gauge, nickel bearing stainless steel.

DESIGN FEATURES

Bowl Depths: 6-1/8" (D11719) and 6-1/2" (D11721).

Coved Corners: Interior vertical and horizontal corners are rounded to a minimum of 2-1/4" radii.

Finish: Exposed surfaces are polished to a satin finish with a highshine bowl radius.

Underside: Fully undercoated to deaden sound.

Self-rimming: Sink is furnished with appropriate number of clamps to provide a secure, watertight installation.

OTHER

Drain Opening: 3-1/2".

Faucet Holes: Available with 0, 1, 2 or 3, 1-1/2" diameter faucet holes, 4" center to center.

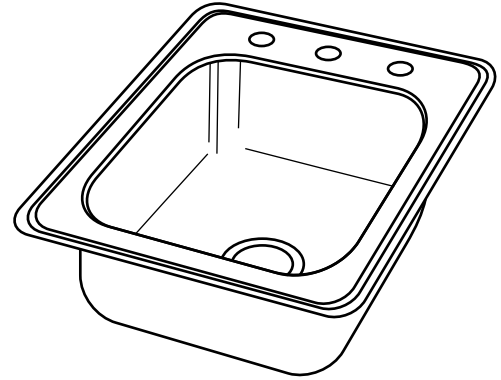

Model D117193

These sinks comply with ANSI Standard A112.19.3M.



These sinks are listed by the International Association of Plumbing and Mechanical Officials as meeting the requirements of the Uniform Plumbing Code.

SINK DIMENSIONS (INCHES)*

Model Number	Overall		Inside Each Bowl			Cutout in Countertop 1 1/2" Radius Corners		No. of Faucet Holes	Ship. Wt. Lbs.
	L	W	L	W	D	L	W		
D11719	17	19	14	14	6 1/8	16 3/8	18 3/8	0, 1, 2 or 3	8
D11721	17	21 1/4	14	15 3/4	6 1/2	16 3/8	20 5/8	0, 1, 2 or 3	9

*Length is left to right. Width is front to back.

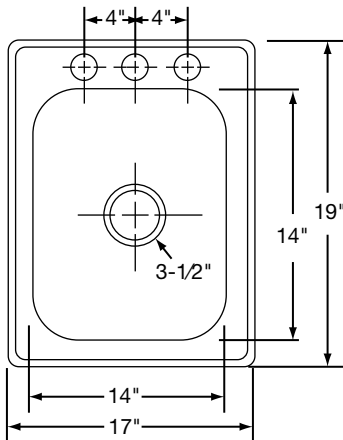

Bowl Depth is 6-1/8"
Model D117193 Illustrated

ALL DIMENSIONS IN INCHES, TO CONVERT TO MILLIMETERS MULTIPLY BY 25.4.

In keeping with our policy of continuing product improvement, Elkay reserves the right to change product specifications without notice.

This specification describes an Elkay product with design, quality and functional benefits to the user. When making a comparison of other producers' offerings, be certain these features are not overlooked.