



Features:

- Cast brass valves
- Ceramic disc valve cartridge
- Adjustable hot limit safety stop
- Pressure Balance cartridge maintains constant output temperature in response to changes in relative hot and cold supply pressures
- Multi-functional showerhead
- Available with Cross or Lever Handle

Pictured: 826/451 Shower Set with Lever Handle

Showerhead Maximum Flow Rate: 2.5 GPM (9.5L/min)

Kit Options	Handle Type	Product Number
Shower Set	Cross	826/450
Shower Set	Lever	826/451
PB Shower Valve Set	Cross	826/130
PB Shower Valve Set	Lever	826/131



Rough & Trim Options	Handle Type	Product Number
Shower Set Trim Only*	Cross	826/485
Shower Set Trim Only*	Lever	826/486
PB Shower Valve Set Trim Only**	Cross	826/535
PB Shower Valve Set Trim Only**	Lever	826/536
Shower Head Only		826/082
Rough Only		899/260/191



Available Finishes:	Finish Code
Polished Chrome	100
Brushed Nickel	144
Platinum Nickel	150
UltraSteel (PVD)	355

* Includes Pressure Balance Shower Valve Trim & Shower Head

**Pressure Balance Shower Valve Trim Only

Handle Options:

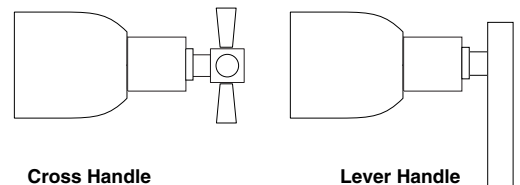

ROUGH-IN DIAGRAM SHOWN ON REVERSE SIDE

CODES & STANDARDS

These products meet and exceed the following codes and standards:

ASME A112.18.1

CSA B125

ASSE1016

 Meets the American Disabilities Act Guidelines and **ANSI A117.1** Requirements for the physically challenged.

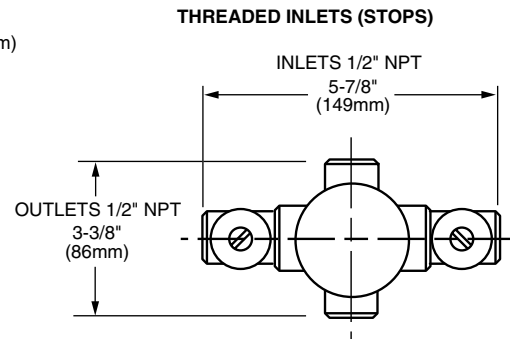
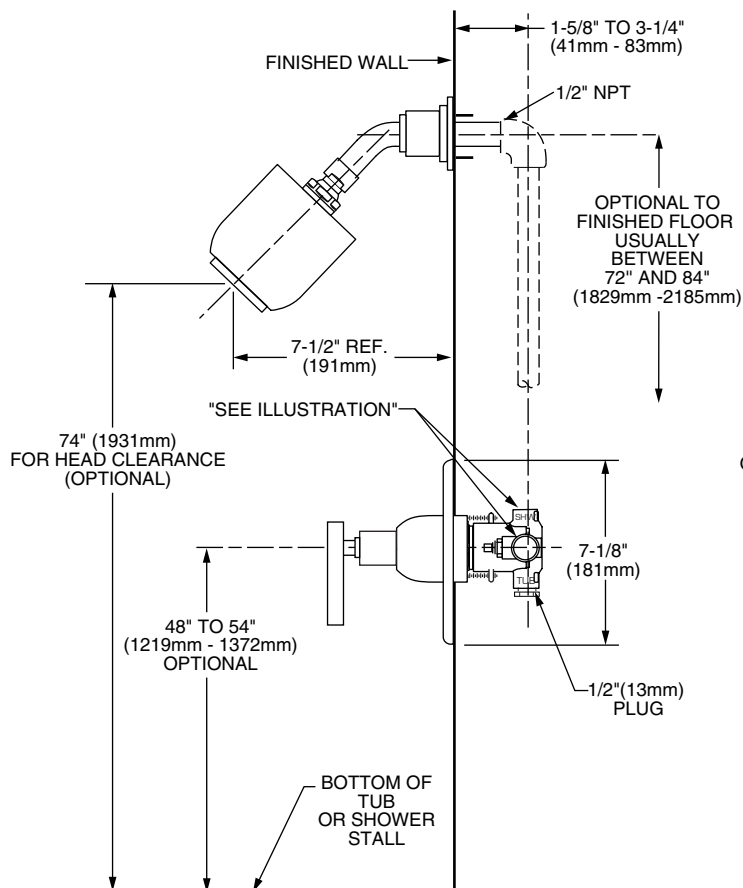
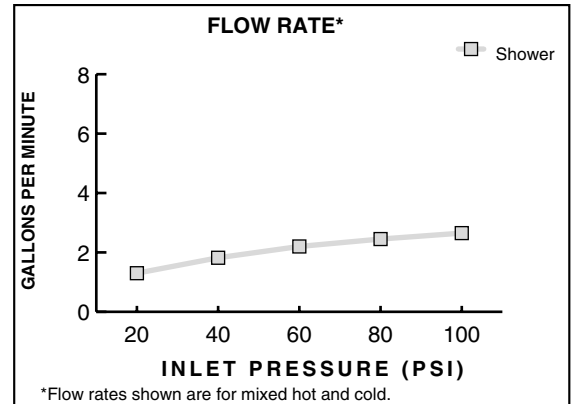

IMPORTANT: These measurements are subject to change or cancellation. No responsibility is assumed for use of superseded or voided pages.