

MODEL ZN80 VENTILATION FAN

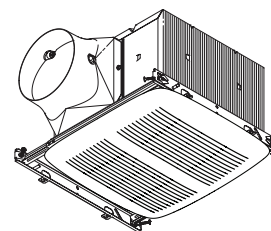

FEATURES

UltraGreen™ Energy Saving DC Motor

- DC motor for efficiency well beyond ENERGY STAR® requirements.
- Multi-speed capability ideal for meeting ASHRAE 62.2, LEED and ENERGY STAR® for Homes requirements. Can be used to comply with CA Title 24, as well as local/spot ventilation needs.

UltraSilent™ Sound Technology

- HVI certified, best-achievable <0.3 Sone level provides nearly silent operation for a relaxing environment.
- State-of-the-art blower and duct outlet design smooths airflow.
- High tech DC motor designed for nearly silent operation.

UltraSmart™ Control Technology

- Powerful operation maintained over a wide range of real-world installations (CFM ratings maintained through at least 0.25" static pressure).
- Infinitely adjustable low cfm setting allows precise adjustment to prevent over-ventilating and maximize efficiency.
- Adjustable time delay sets how long fan will run on high speed before returning to a continuous lower speed.

UltraQuick™ Installation Technology

- Unique telescoping mounting frame fits through retrofit drywall opening to allow easy installation from the room side. No attic access needed!
- Captive screws allow for easy new construction installation.
- Mounting frame positioning tabs provide easy vertical positioning for new construction.
- Easy to insert and remove snap-in housing. No screws required!
- Easy to insert and remove snap-in blower.
- Inside or outside duct connector and knockout plate mounting provides flexibility for new construction or retrofit.

U.L. Listed for use over bathtubs and showers when connected to a GFCI protected branch circuit (ceiling mount only).

3-year warranty.

DIMENSIONS (Inches)

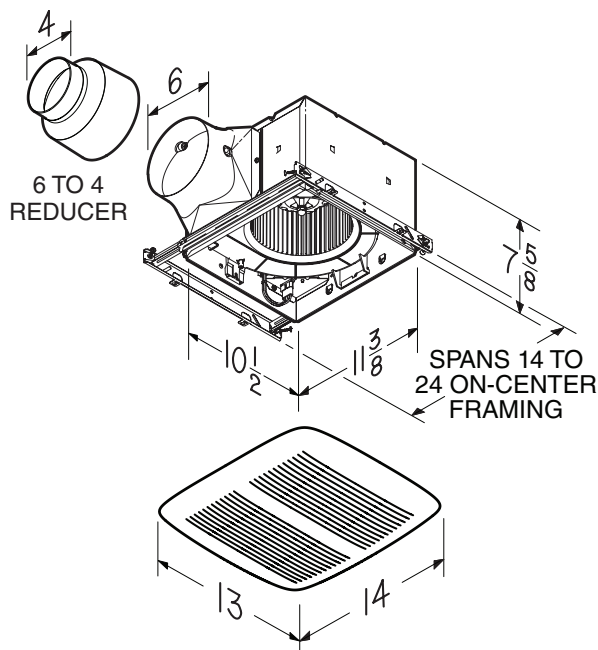

Broan-NuTone LLC Hartford, Wisconsin www.nutone.com 888-336-3948

REFERENCE	QTY.	REMARKS	Project
			Location
			Architect
			Engineer
			Contractor
			Submitted by Date

HVI PERFORMANCE

Airflow Rate Setting (CFM)	6" Duct					4" Duct				
	0.1 Ps - Static Pressure (inH2O)				0.25 Ps	0.1 Ps - Static Pressure (inH2O)				0.25 Ps
	Airflow (CFM)	Sound (Sones)	Power (Watts)	Efficacy (CFM/Watt)	Airflow (CFM)	Airflow (CFM)	Sound (Sones)	Power (Watts)	Efficacy (CFM/Watt)	Airflow (CFM)
80	80	< 0.3	5.8	13.7	79	80	0.3	7.6	10.5	80
70	70	< 0.3	5.1	13.7	71	70	< 0.3	6.5	10.7	70
60	60	< 0.3	4.4	13.6	61	60	< 0.3	5.5	10.9	60
50	50	< 0.3	4.0	12.7	49	50	< 0.3	5.1	10.3	47
40	40	< 0.3	3.7	12.1	36	40	< 0.3	4.3	10.9	34
30	30	< 0.3	3.4	11.4	23	30	< 0.3	3.9	10.2	22

ELECTRICAL & WEIGHT

Volts	Hz	Amps	Shipping Weight (lbs.)
120	60	0.1	12.5



HVI-2100 CERTIFIED RATINGS comply with new testing technologies and procedures prescribed by the Home Ventilating Institute, for off-the-shelf products, as they are available to consumers. Product performance is rated at 0.1 in. static pressure, based on tests conducted in a state-of-the-art test laboratory. Sones are a measure of humanly-perceived loudness, based on laboratory measurements.

FAN CAPABILITY

