

MODEL ZB110L VENTILATION FAN WITH LIGHT

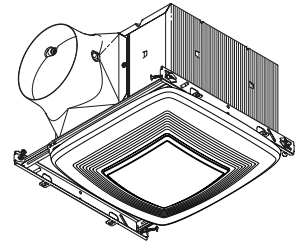

FEATURES

UltraGreen™ Energy Saving DC Motor

- DC motor for efficiency well beyond ENERGY STAR® requirements.
- Multi-speed capability ideal for meeting ASHRAE 62.2, LEED and ENERGY STAR® for Homes requirements. Can be used to comply with CA Title 24, as well as local/spot ventilation needs.

UltraSilent™ Sound Technology

- HVI certified, best-achievable <0.3 Sone level provides nearly silent operation for a relaxing environment.
- State-of-the-art blower and duct outlet design smooths airflow.
- High tech DC motor designed for nearly silent operation.

UltraSmart™ Control Technology

- Powerful operation maintained over a wide range of real-world installations (CFM ratings maintained through at least 0.25" static pressure).
- Infinitely adjustable low cfm setting allows precise adjustment to prevent over-ventilating and maximize efficiency.
- Adjustable time delay sets how long fan will run on high speed before returning to a continuous lower speed.

UltraLucent™ Lighting Technology

- Two, ENERGY STAR® qualified 18 watt (max) GU24, 3500K bulbs brightly illuminate room for most any task (bulbs included).
- One, 4 watt (max) C7 type night-light provides night-time convenience (bulb not included).
- Well-diffused, wide light dispersal floods room for maximum effectiveness and keeps bulbs from showing through lens.
- Enclosed reflector for minimal light visibility through the grille.

UltraQuick™ Installation Technology

- Unique telescoping mounting frame fits through retrofit drywall opening to allow easy installation from the room side. No attic access needed!
- Captive screws allow for easy new construction installation.
- Mounting frame positioning tabs provide easy vertical positioning for new construction.
- Easy to insert and remove snap-in housing. No screws required!

- Easy to insert and remove snap-in blower.
- Inside or outside duct connector and knockout plate mounting provides flexibility for new construction or retrofit.

U.L. Listed for use over bathtubs and showers when connected to a GFCI protected branch circuit (ceiling mount only).

U.L. Listed for use in insulated ceilings (Type IC).

3-year warranty on product, 1-year warranty on bulbs.

DIMENSIONS (Inches)

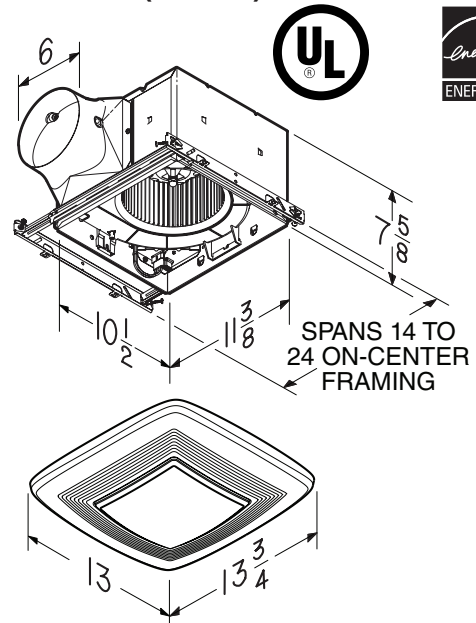

Broan-NuTone LLC Hartford, Wisconsin www.broan.com 800-558-1711

REFERENCE	QTY.	REMARKS	Project
			Location
			Architect
			Engineer
			Contractor
			Submitted by Date



PERFORMANCE SPECIFICATIONS

MODEL ZB110L VENTILATION FAN WITH LIGHT

ELECTRICAL & WEIGHT

HVI PERFORMANCE

Airflow Rate Setting (CFM)	6" Duct				
	0.1 Ps - Static Pressure (inH2O)				0.25 Ps
	Airflow (CFM)	Sound (Sones)	Power (Watts)	Efficacy (CFM/Watt)	Airflow (CFM)
110	110	< 0.3	8.7	12.6	110
100	100	< 0.3	7.3	13.6	100
90	90	< 0.3	6.5	13.8	90
80	80	< 0.3	6.0	13.3	80
70	70	< 0.3	5.2	13.4	70
60	60	< 0.3	4.6	13.0	60
50	50	< 0.3	4.1	12.1	50
40	40	< 0.3	3.6	11.1	40
30	30	< 0.3	3.3	9.0	30



HVI-2100 CERTIFIED RATINGS comply with new testing technologies and procedures prescribed by the Home Ventilating Institute, for off-the-shelf products, as they are available to consumers. Product performance is rated at 0.1 in. static pressure, based on tests conducted in a state-of-the-art test laboratory. Sones are a measure of humanly-perceived loudness, based on laboratory measurements.

Volts	Hz	Amps*	Shipping Weight (lbs.)
120	60	0.9	13.7

* Total connected load



FAN CAPABILITY

