

MODEL ZB110M VENTILATION FAN

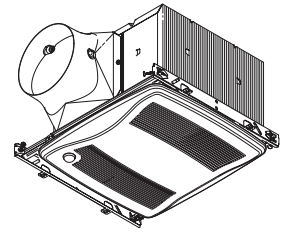

FEATURES

UltraGreen™ Energy Saving DC Motor

- DC motor for efficiency well beyond ENERGY STAR® requirements.
- Multi-speed capability ideal for meeting ASHRAE 62.2, LEED and ENERGY STAR® for Homes requirements. Can be used to comply with CA Title 24, as well as local/spot ventilation needs.

UltraSilent™ Sound Technology

- HVI certified, best-achievable <0.3 Sone level provides nearly silent operation for a relaxing environment.
- State-of-the-art blower and duct outlet design smooths airflow.
- High tech DC motor designed for nearly silent operation.

UltraSmart™ Control Technology

- Powerful operation maintained over a wide range of real-world installations (CFM ratings maintained through at least 0.25" static pressure).
- Infinitely adjustable low cfm setting allows precise adjustment to prevent over-ventilating and maximize efficiency.
- Adjustable time delay sets how long fan will run on high speed before returning to a continuous lower speed.

UltraQuick™ Installation Technology

- Unique telescoping mounting frame fits through retrofit drywall opening to allow easy installation from the room side. No attic access needed!
- Captive screws allow for easy new construction installation.
- Mounting frame positioning tabs provide easy vertical positioning for new construction.
- Easy to insert and remove snap-in housing. No screws required!
- Easy to insert and remove snap-in blower.
- Inside or outside duct connector and knockout plate mounting provides flexibility for new construction or retrofit.

UltraSense™ Motion Sensing Technology

- Detects motion at the ceiling where coverage may be improved over wall-mounted sensor.
- Automatically switches fan to maximum airflow (CFM) when motion is detected.
- After motion is not detected, fan operates at maximum airflow (CFM) until UltraSmart™ user adjustable (5 to 60 minutes) time delay set point is reached then fan reduces to continuous airflow (CFM) level.

U.L. Listed for use over bathtubs and showers when connected to a GFCI protected branch circuit (ceiling mount only).

3-year warranty.

DIMENSIONS (Inches)

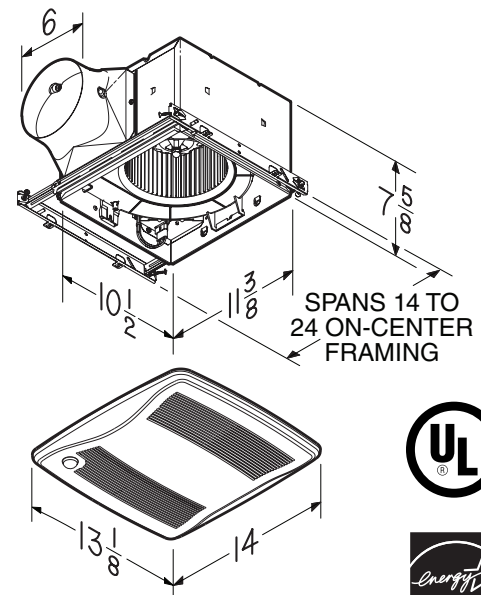

Broan-NuTone LLC Hartford, Wisconsin www.broan.com 800-558-1711

| REFERENCE | QTY. | REMARKS | Project |
|-----------|------|---------|--|
| | | | Location |
| | | | Architect |
| | | | Engineer |
| | | | Contractor |
| | | | Submitted by Date |



PERFORMANCE SPECIFICATIONS

MODEL ZB110M VENTILATION FAN

ELECTRICAL & WEIGHT

HVI PERFORMANCE

| Airflow Rate Setting (CFM) | 6" Duct | | | | |
|----------------------------|---|---------------|---------------|---------------------|---------------|
| | 0.1 Ps - Static Pressure (inH ₂ O) | | | | 0.25 Ps |
| | Airflow (CFM) | Sound (Sones) | Power (Watts) | Efficacy (CFM/Watt) | Airflow (CFM) |
| 110 | 110 | < 0.3 | 8.3 | 13.3 | 110 |
| 100 | 100 | < 0.3 | 7.6 | 13.2 | 100 |
| 90 | 90 | < 0.3 | 7.0 | 12.9 | 90 |
| 80 | 80 | < 0.3 | 6.4 | 12.5 | 80 |
| 70 | 70 | < 0.3 | 5.7 | 12.3 | 70 |
| 60 | 60 | < 0.3 | 5.2 | 11.5 | 60 |
| 50 | 50 | < 0.3 | 4.7 | 10.6 | 50 |
| 40 | 40 | < 0.3 | 4.3 | 9.3 | 40 |
| 30 | 30 | < 0.3 | 3.9 | 7.7 | 30 |



HVI-2100 CERTIFIED RATINGS comply with new testing technologies and procedures prescribed by the Home Ventilating Institute, for off-the-shelf products, as they are available to consumers. Product performance is rated at 0.1 in. static pressure, based on tests conducted in a state-of-the-art test laboratory. Sones are a measure of humanly-perceived loudness, based on laboratory measurements.

| Volts | Hz | Amps | Shipping Weight (lbs.) |
|-------|----|------|------------------------|
| 120 | 60 | 0.4 | 12.0 |



FAN CAPABILITY

