

Wall Heaters

MODELS: 9810, 9815, 9819 SERIES

SAFETY INSTRUCTIONS

- Carefully read all instructions and product labels before beginning installation.
- Only mount the heater in a vertical position.
- **Mount the heater at least 6" above the finished floor.**
- Do not mount the heater over a bathtub or in a shower stall enclosure.
- **When mounted, the heater should not be closer than 12" to an adjacent wall.**
- Do not block the wall heater – i.e., by mounting under a towel rack, behind a door, etc.

ELECTRICAL SPECIFICATIONS

NOTE: See wiring label on heater housing. The heater may be wired for either 120V or 240V operation. All three heater models require a separate circuit.

UNIT DIMENSIONS

Housing: 12½" high x 10½" wide x 3⅞" deep.

Grille: 14¾" high x 11⅞" wide x 1" deep.

Wall Cutout: 12⅝" high x 10⅝" wide.

MOUNTING THE HOUSING

(New Construction)

Refer to Figure 1.

1. Choose heater location. **Make sure the heater will not be mounted closer than 12" from a vertical surface or 6" from the floor.**
2. Using nails or screws, mount one side of housing to wall stud. The flange must be flush to the stud.
3. Run wiring from circuit breaker or fuse box to heater location.
4. Install box connector into wiring entrance hole in housing's junction box.
5. Pull wiring through entrance hole and secure cable to box connector. Allow 6" of wiring to make connections.
6. Finished wall opening should be 12⅝" high x 10⅝" wide.

MOUNTING THE HOUSING

(Existing Construction)

1. Choose heater location. Make sure the heater will not be mounted closer than 12" from a vertical surface or 6" from the floor.
2. **Refer to Figure 2.** Make wall cutout next to a wall stud. Cutout size: 12⅝" high x 10⅝" wide. (with frame.)
3. Run wiring from circuit breaker or fuse box to heater location.
4. Install box connector into wiring entrance hole in housing's junction box.
5. Pull wiring through cutout and secure cable to box connector. Allow 6" of wiring to make connections.
6. **Refer to Figure 3.** Insert TOP of housing into cutout first so that box connector clears the wall. Then, insert bottom of housing into cutout. **The flange must be flush with the wall.**
7. Use nails or screws to mount one side of housing to wall stud.

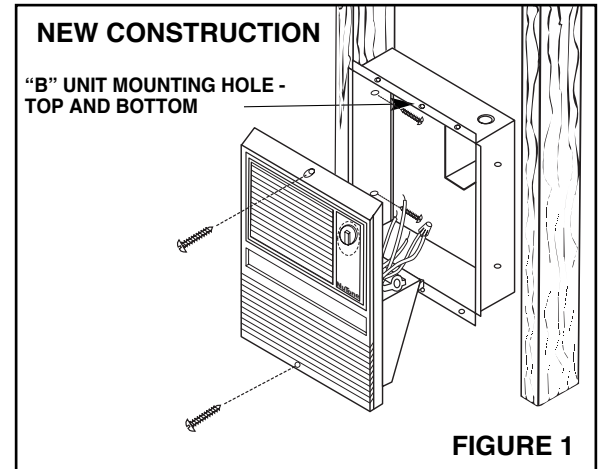

FIGURE 1

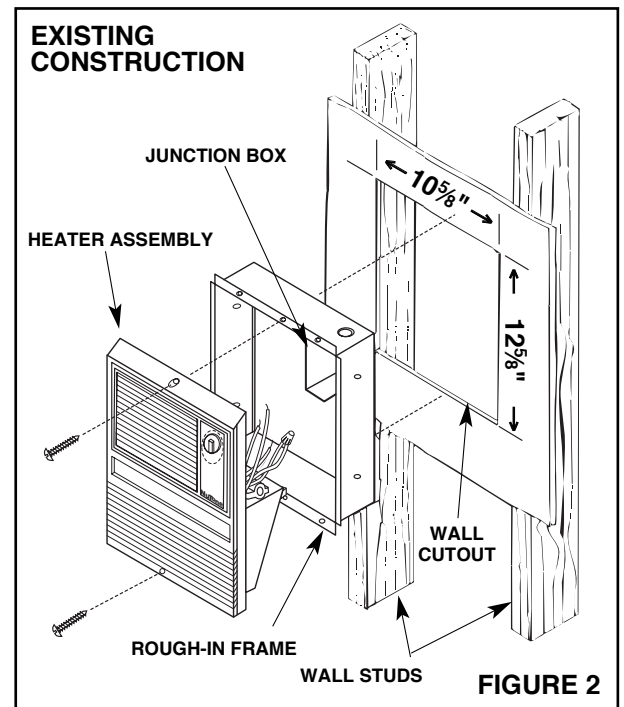

FIGURE 2

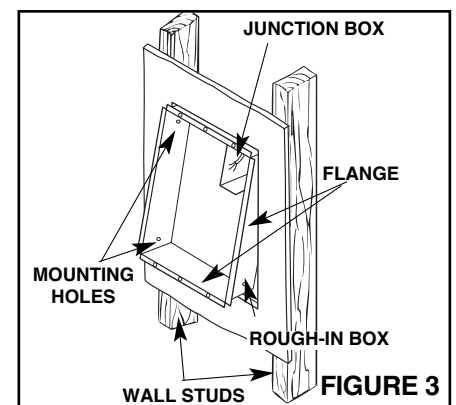

FIGURE 3

WIRING CONNECTIONS

All wiring must comply with local codes and unit must be properly grounded.

1. While making wiring connections, support the heater assembly on the bottom of the rough-in frame.
2. For 120 Volt operation, make wiring connections as shown in Figure 4.
3. For 240 Volt operation, make wiring connections as shown in Figure 5.
4. Use wire nuts to make connections. Insulate all connections with electrical tape.

SECURING THE HEATER

1. Dress all wiring back to into junction box.
2. Locate center holes in housing flange and align with mounting holes in grille.
3. Use two provided screws to attach grille to housing.

OPERATION

Turn thermostat fully clockwise to HIGH position. Allow heater to run until room is at desired temperature. Adjust thermostat as required to maintain desired temperature. Turn the thermostat to FULL COUNTERCLOCKWISE position when operation is no longer desired.

Thermal protector: If for any reason temperatures increase beyond normal limits, a safety thermal fuse will shut heater off. The heater will require servicing by a qualified electrician.

Check entire installation to determine cause of overheating.

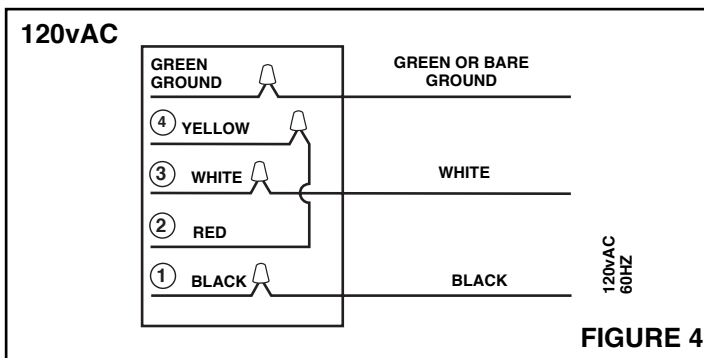

FIGURE 4

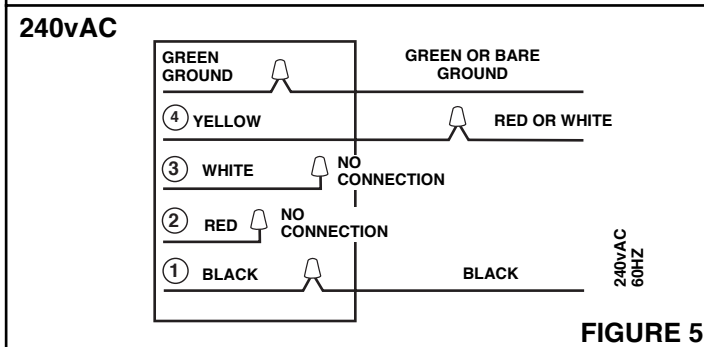

FIGURE 5

NuTone®

One Year Limited Warranty

WARRANTY OWNER: NuTone warrants to the original consumer purchaser of its products that such products will be free from defects in materials or workmanship for a period of one (1) year from the date of original purchase. **THERE ARE NO OTHER WARRANTIES, EXPRESS OR IMPLIED, INCLUDING, BUT NOT LIMITED TO, IMPLIED WARRANTIES OF MERCHANTABILITY OR FITNESS FOR A PARTICULAR PURPOSE.**

During this one year period, NuTone will, at its option, repair or replace, without charge, any product or part which is found to be defective under normal use and service. THIS WARRANTY DOES NOT EXTEND TO FLUORESCENT LAMP STARTERS OR TUBES, FILTERS, DUCT, ROOF CAPS, WALL CAPS AND OTHER ACCESSORIES FOR DUCTING. This warranty does not cover (a) normal maintenance and service or (b) any products or parts which have been subject to misuse, negligence, accident, improper maintenance or repair (other than by NuTone), faulty installation or installation contrary to recommended installation instructions.

The duration of any implied warranty is limited to the one year period as specified for the express warranty. Some states do not allow limitation on how long an implied warranty lasts, so the above limitation may not apply to you.

NUTONE'S OBLIGATION TO REPAIR OR REPLACE, AT NUTONE'S OPTION, SHALL BE THE PURCHASER'S SOLE AND EXCLUSIVE REMEDY UNDER THIS WARRANTY. NUTONE SHALL NOT BE LIABLE FOR INCIDENTAL, CONSEQUENTIAL OR SPECIAL DAMAGES ARISING OUT OF OR IN CONNECTION WITH PRODUCT USE OR PERFORMANCE. Some states do not allow the exclusion or limitation of incidental or consequential damages, so the above limitation or exclusion may not apply to you. This warranty gives you specific legal rights, and you may also have other rights, which vary from state to state. This warranty supersedes all prior warranties.

WARRANTY SERVICE: To qualify for warranty service, you must (a) notify NuTone at the address stated below or telephone 1/800-543-8687, (b) give the model number and part identification and (c) describe the nature of any defect in the product or part. At the time of requesting warranty service, you must present evidence of the original purchase date.

Date of Installation

Builder or Installer

Model No. and Product Description

IF YOU NEED ASSISTANCE OR SERVICE:

For the location of your nearest NuTone Independent Authorized Service Center:

Residents of the contiguous United States Dial Free 1-800-543-8687

Please be prepared to provide:

Product model number • Date and Proof of purchase • The nature of the difficulty

Residents of Alaska or Hawaii should write to: NuTone Inc. Attn: Department of National Field Service, 4820 Red Bank Road, Cincinnati Ohio 45227-1599.

Residents of Canada should write to: Broan-NuTone Canada, 1140 Tristar Drive, Mississauga, Ontario, Canada L5T 1H9.

Rev. 01/2005

Product specifications subject to change without notice.

4820 Red Bank Road, Cincinnati, Ohio 45227
Printed in U.S.A., Rev. 2/2005, Part No. 44960