

CHICAGO FAUCETS

Last As Long As The Building



2100 SOUTH CLEARWATER DRIVE
DES PLAINES, ILLINOIS 60018-5999

FITTING NO.

732-OH

SUBMITTED MODEL NO.

JOB NAME

ITEM NO.

SUBMITTED AS SHOWN

SUBMITTED AS NOTED

SEE ATTACHED FOR
SUBMITTED MODIFICATION



ADA COMPLIANT

IS ASSUMED FOR USE OF SUPERCEDED OR VOIDED DATA.

ROUGHING IN DIMENSIONS MAY VARY AND ARE SUBJECT TO CHANGE. NO RESPONSIBILITY

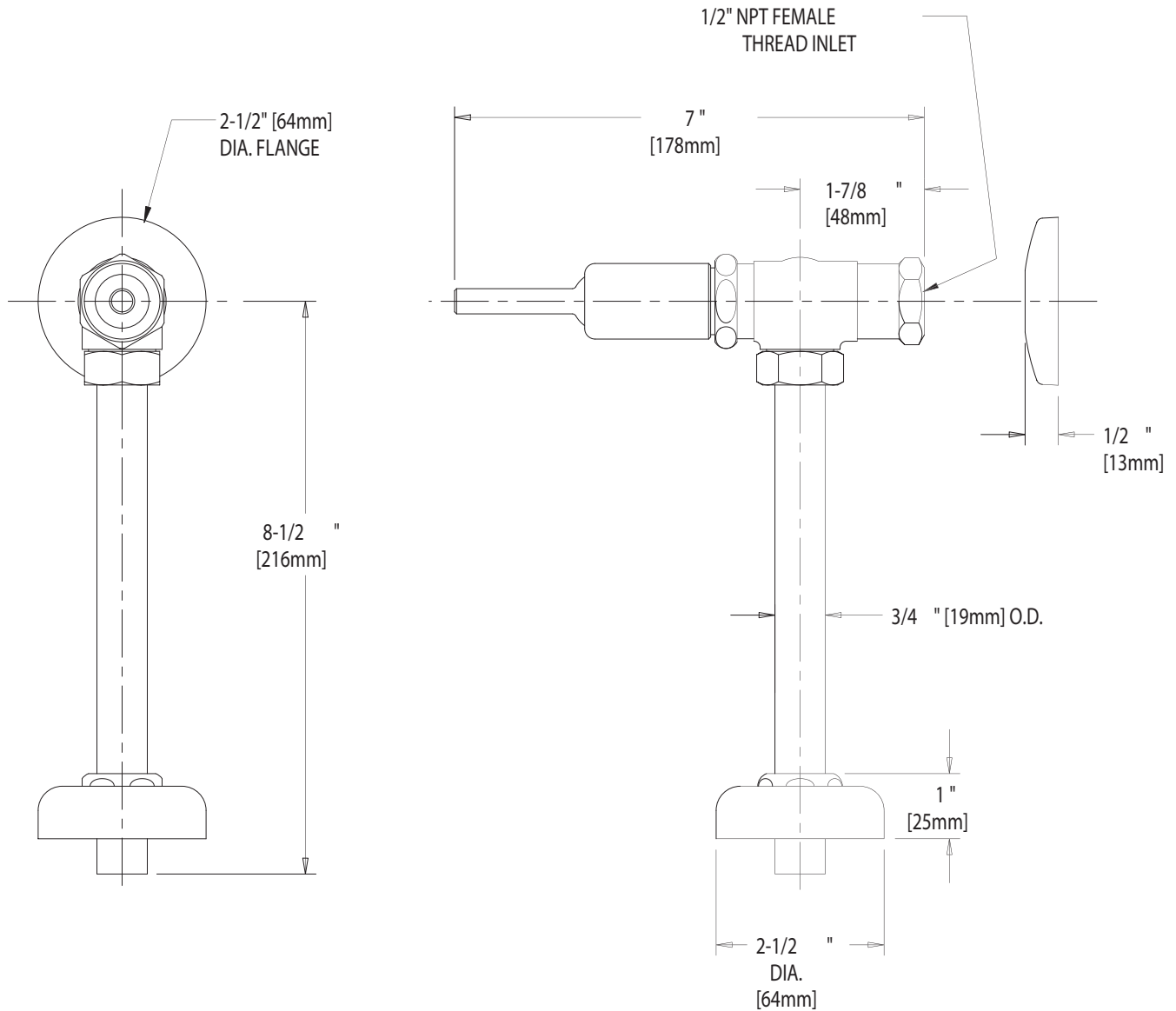

DIMENSIONS IN INCHES AND [MILLIMETERS].

TECHNICAL DATA

- ANGLE VALVE WITH LOOSE WALL FLANGE
- LONG BONNET NON-SAG OSCILLATING HANDLE
- NAIAD SELF CLOSING CARTRIDGE
- TAILPIECE AND ESCUTCHEON ASSEMBLY
- POLISHED CHROME FINISH

- ASME A112.18.1M COMPLIANT
- CSA B125 COMPLIANT

DATE: 05-02-02
BY: SID
CHK'D:
APP'D:
REV: A

732-OH