

# CHICAGO FAUCETS



2100 SOUTH CLEARWATER DRIVE  
DES PLAINES, ILLINOIS 60018-5999

FITTING NO.

527

SUBMITTED MODEL NO.

Last As Long As The Building

JOB NAME

ITEM NO.

SUBMITTED AS SHOWN

SUBMITTED AS NOTED

SEE ATTACHED FOR  
SUBMITTED MODIFICATION



ADA COMPLIANT

IS ASSUMED FOR USE OF SUPERCEDED OR VOIDED DATA.

ROUGHING IN DIMENSIONS MAY VARY AND ARE SUBJECT TO CHANGE. NO RESPONSIBILITY

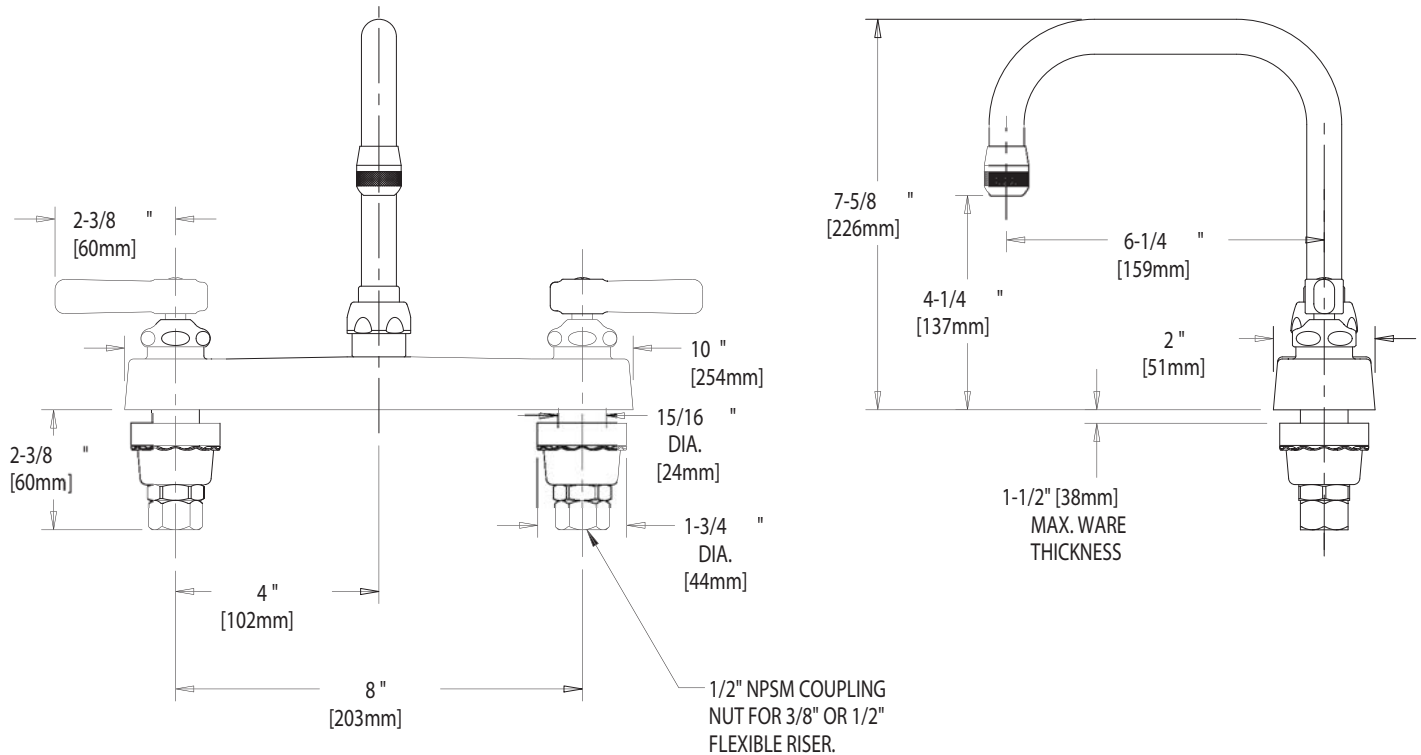

DIMENSIONS IN INCHES AND [MILLIMETERS].

## TECHNICAL DATA

- DECK MOUNTED FITTING
- DB6A RIGID/SWING DOUBLE BEND SPOUT
- 369 INDEXED LEVER HANDLES
- QUATURN OPERATING CARTRIDGES
- FINISH: CHROME PLATE

- E1 QUIXTOP OUTLET
- 1/2" NPSM COUPLING NUTS FOR 3/8" OR 1/2" FLEXIBLE RISERS
- ASME A112.18.1M COMPLIANT
- CSA B125 COMPLIANT
- NSF 61 COMPLIANT

DATE: 04-24-02

BY: SID

CHK'D:

APP'D:

REV: A

527