



# Assembly Instructions Mode d'assemblage

DATE STAMP	
------------	--

## CALL US FIRST

1-877-PREPAC1

1-877-773-7221



Mon - Fri 7am - 4pm PST  
10am - 7pm EST

- For help with assembly
- If you have received a damaged or defective part or are missing hardware.

We will process replacement parts in 2 business days or less. Parts are shipped via UPS Ground or mail.





### Before you call please:

- 1) Record the following information from the shipping label on the outside of the box. You will need it for warranty purposes:
  - Ship To Name
  - Sales Order Number
- 2) Note the product model number.
- 3) Review the contents of your shipment to determine what you are missing.

### Online Option:

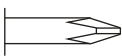
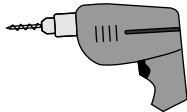
Fill out the Replacement Parts Order form in the Product Support section of our website: [www.prepacmfg.com](http://www.prepacmfg.com)

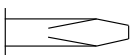
Pour le service en français, contactez s'il vous plaît votre détaillant.

Required Tools / Outils nécessaires		Optional Tools / Outils Facultatif
Screwdrivers <i>Tournevis</i> 	 Phillips Head <i>À pointe</i>	Using a power screwdriver will speed up assembly. <b>Caution</b> Do not over tighten any screw. The last few turns of each screw should be done very slowly or by hand.  Utiliser la puissance un tournevis accélérera l'assemblée. <b>Attention</b> Au-dessus de ne serrer aucune vis. Les derniers tours de chaque vis devraient être faits très lentement ou à la main.
	 Flat Head <i>Principal plat</i>	
 Hammer <i>Marteau</i>		

# Triple Barrister Tower Haute Étagère Barrister Triple Model # MB-1200

This product is shipped in  
**2 cartons**

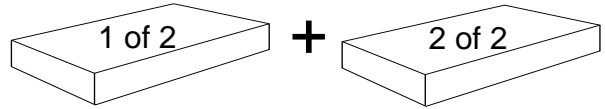

Make sure you have both cartons. Sometimes cartons shipped on the same day get separated and are delivered on different days.



Prepac Manufacturing Ltd.  
6705 Dennett Place  
Delta, BC V4G 1N4

LB-0497-R  
2013-05-29

# Tower Parts / Pièces de la tour

**T1**

Top / *le Dessus* (1)  
**TP-0912** Black / Noir  
**TP-0992** Cherry / Cerise  
**TP-0962** Espresso  
**TP-0282** Oak / Chêne

**T2**

Left Side (1)  
*Côté gauche*  
**SL-0910** Black / Noir  
**SL-0990** Cherry / Cerise  
**SL-0960** Espresso  
**SL-0230** Oak / Chêne

**T3**

Center Gable (2)  
*Montant du centre*  
**GA-0208** Black / Noir  
**GA-0268** Espresso

**T4**

Right Side (1)  
*Côté droit*  
**SR-0910** Black / Noir  
**SR-0990** Cherry / Cerise  
**SR-0960** Espresso  
**SR-0230** Oak / Chêne

**T5**

Top Molding (3)  
*Moulure supérieure*  
**TR-0911** Black / Noir  
**TR-0991** Cherry / Cerise  
**TR-0961** Espresso  
**TR-0201** Oak / Chêne

**T6**

Side Molding (4)  
*Moulure latérale*  
**TR-0910** Black / Noir  
**TR-0990** Cherry / Cerise  
**TR-0960** Espresso  
**TR-0200** Oak / Chêne

**T7**

Backer (3)  
*Dos*  
**BB-0103** Black  
**BB-0163** Espresso

**T8**

Adjustable Shelves  
*Tablettes ajustable* (27)  
**SH-0214** Black / Noir  
**SH-0264** Espresso

**T9**

Bottom / *Bas* (1)  
**BT-0282** Black / Noir  
**BT-0262** Espresso

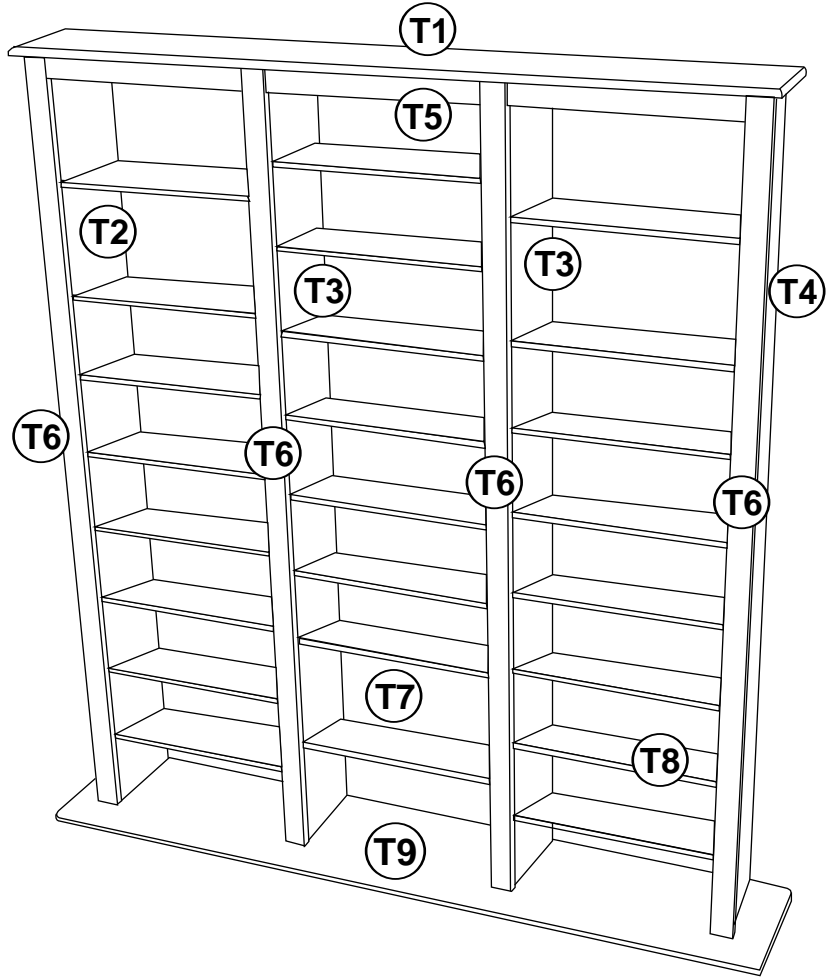

# Hardware / Quincaillerie

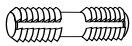

Plastic Dowels (26)  
*Goujons en plastique*  
**RM-0072**

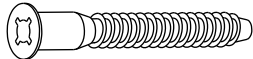

2" Confirmat Screws (8)  
*Vis Confirmat 2"*  
**RM-0001**

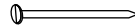

3/4" Nail (60)  
*Clou 3/4"*  
**RM-0022**



15mm Zinc Cam (4)  
*Ferrure en zinc*  
**RM-0103**



Metal Dowel Pins (116)  
*Goujons de métal*  
**RM-0014**

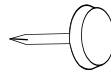

Tack Glide (8)  
*Patins à clou*  
**RM-0139**

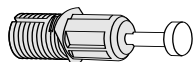

Blue Rapid Rod (4)  
*Tige rapide bleu*  
**RM-0583**



Plain Wood Dowel (4)  
*Goujons de bois naturel*  
**RM-0069**

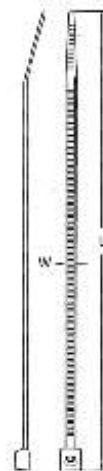

Cable Tie (1)  
*Attache pour câble*  
**RM-0459**



Mounting Base (2)  
*Base de support*  
**RM-0458**

#6-3/4" Pan Head  
 Screw (1)  
*Vis #6-3/4 po.*  
**RM-0460**

**HP-0608**

- 1.** Insert cams into the top and front of each side.  
*Insérez les ferrures dans le dessus et l'avant de chaque côté.*

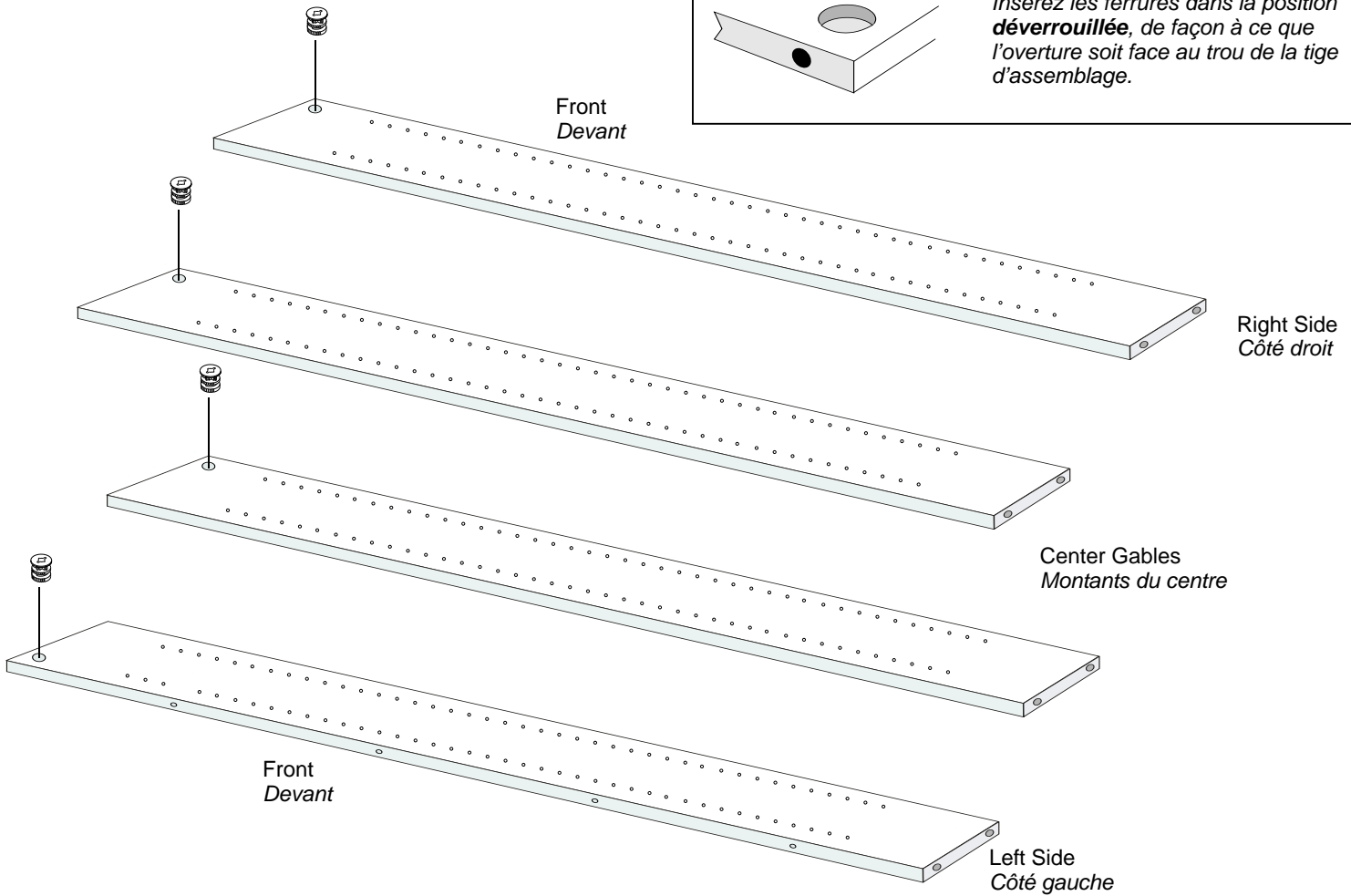
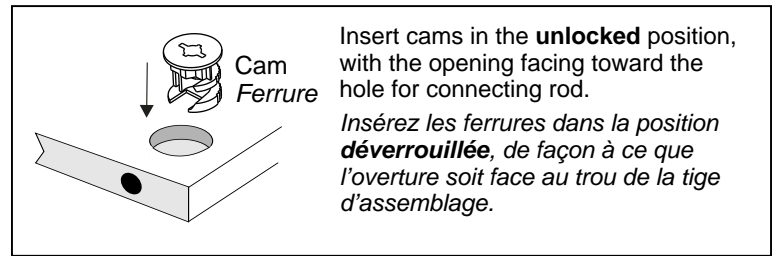

- 2.** Insert **Blue Rapid Rods** into the underside of the top in the location shown. Then, using a hammer, GENTLY tap **4 Plain Wood Dowels** and **6 Black Plastic Dowels** HALFWAY into the underside of the top.  
*Insérer les tiges rapides bleues dans le dessous du dessus dans l'endroit montré. Puis, utilisant un marteau, brancher DOUCEMENT 4 goujons de bois naturel et 6 goujons en plastique À MI-CHEMIN dans le dessous du dessus.*

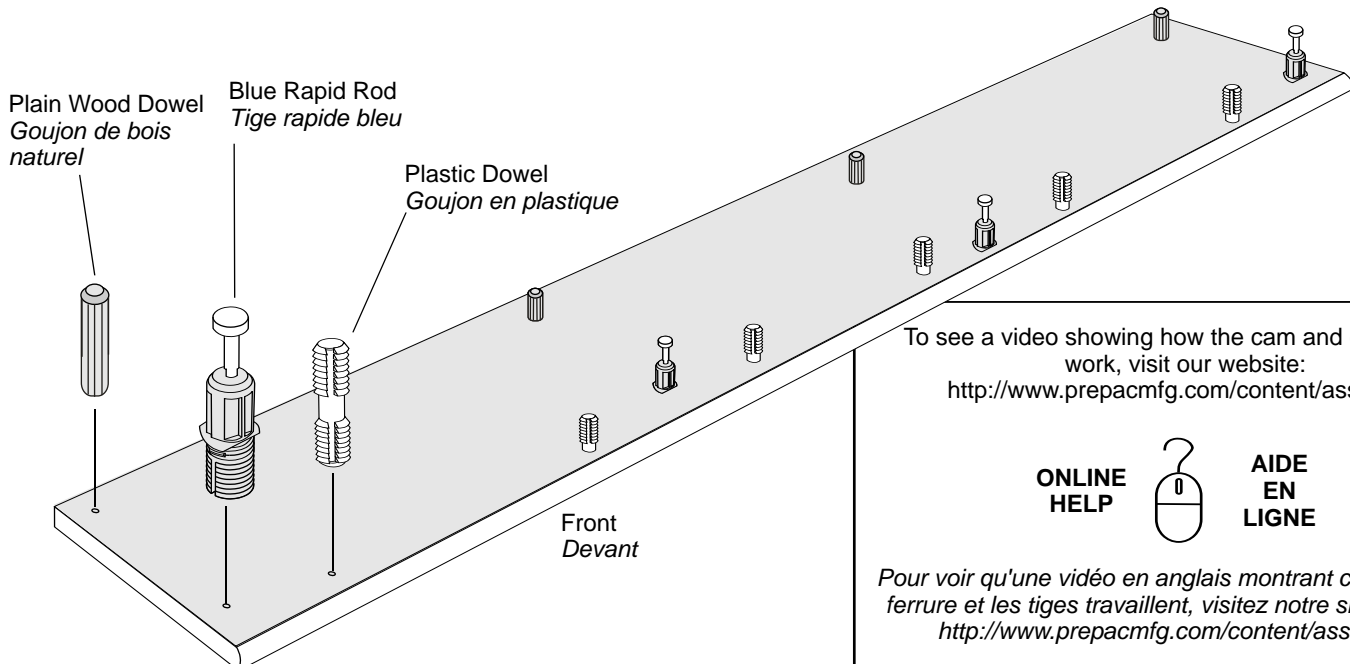

To see a video showing how the cam and connectors work, visit our website:  
<http://www.prepacmfg.com/content/assembly>

ONLINE  
HELP



AIDE  
EN  
LIGNE

Pour voir qu'une vidéo en anglais montrant comment les ferrure et les tiges travaillent, visitez notre site internet:  
<http://www.prepacmfg.com/content/assembly>

- 3.** Attach top to sides & center gables and tighten cams.  
*Fixez le dessus aux côtés et aux pignons centraux et serrez les ferrures.*

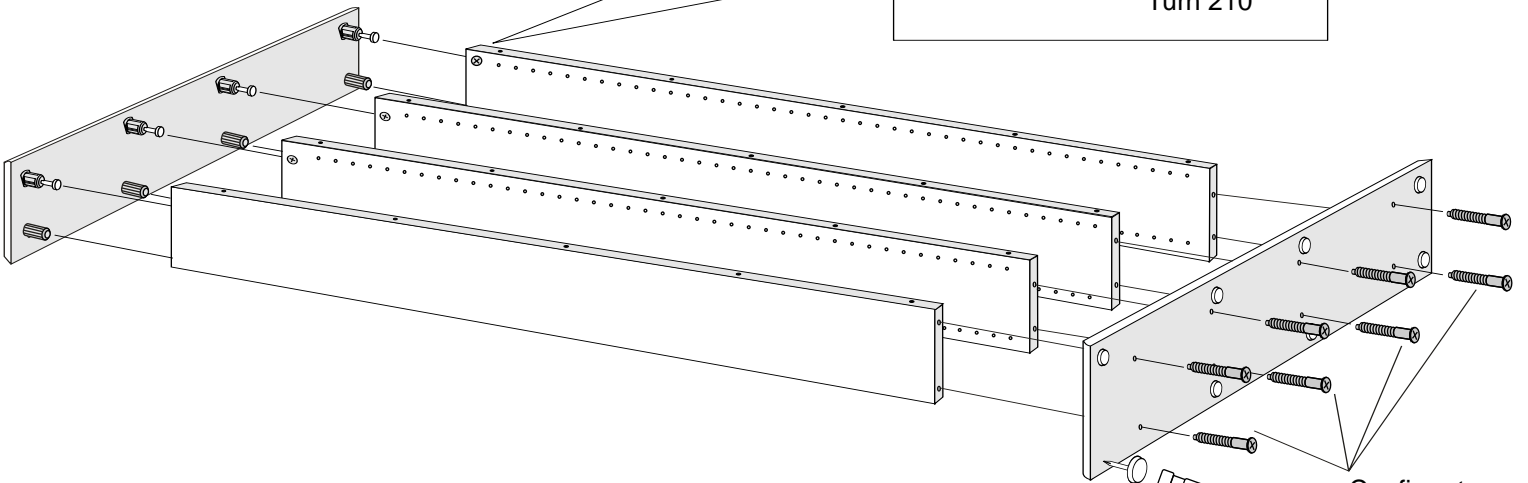
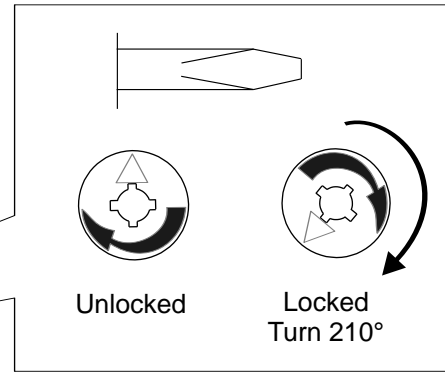

- 4.** Attach bottom with Confirmat screws. Then, hammer Tack Glides into bottom as shown.  
*Fixez le bas à l'aide des vis Confirmat. Puis, à l'aide d'un marteau, insérez les patins à clou dans le bas comme dans l'illustration.*

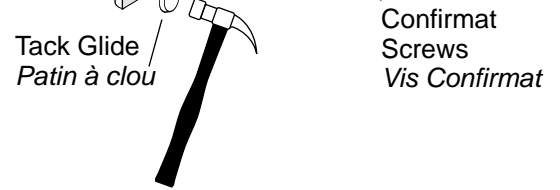

- 5.** GENTLY hammer plastic dowels halfway into each molding.  
*Marteler DOUCEMENT les goujons en plastique à mi-chemin dans chaque moulure.*

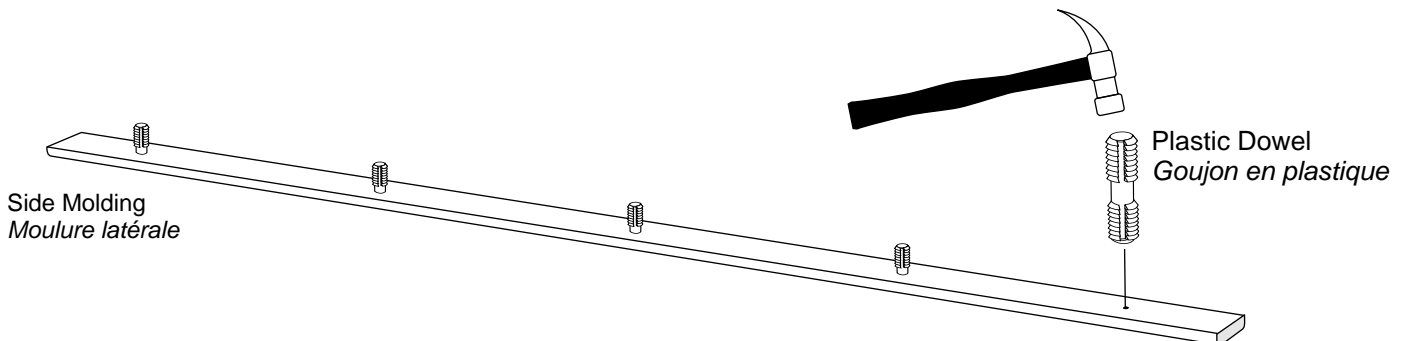

- 6.** Turn moldings over and align with the holes on the cabinet sides and gables.  
Press down firmly on the molding to secure in place.

*Retourner les moulures et aligner avec les trous des côtés et pignons de coffret.  
Enfoncer fermement sur le moulure pour fixer en place.*

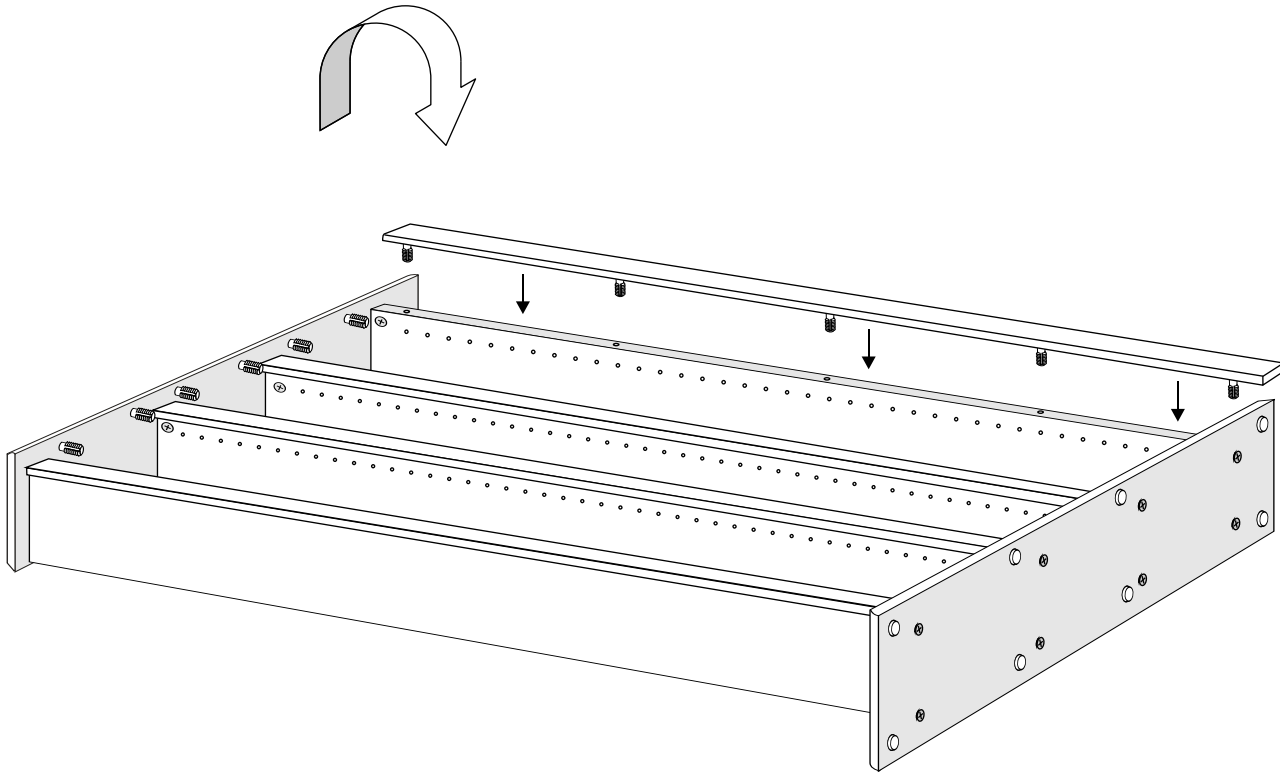

- 7.** Align holes on top moldings with plastic dowels in the top. Press firmly on the moldings to secure in place.

*Aligner les trous sur les moulures supérieur avec les goujons en plastique dans le dessus.  
Presser fermement sur les moulures pour fixer en place.*

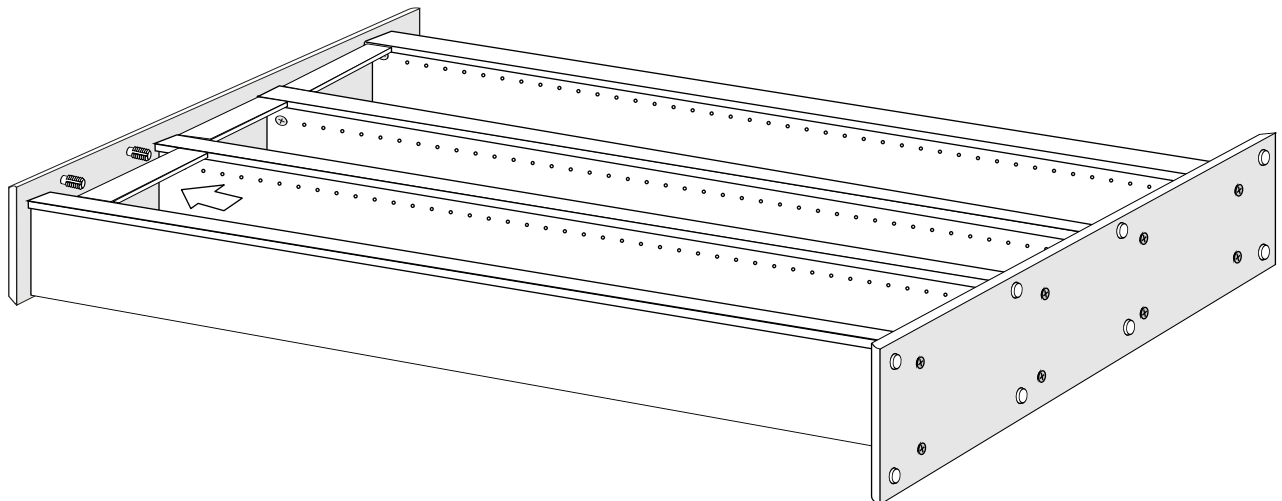

- 8.** Attach backer using  $\frac{3}{4}$ " nails. Leave 2-3" space from each corner.  
 Posez le dos à l'aide des clou  $\frac{3}{4}$ ". Laissez des 2 ou 3" l'espace de chaque coin.

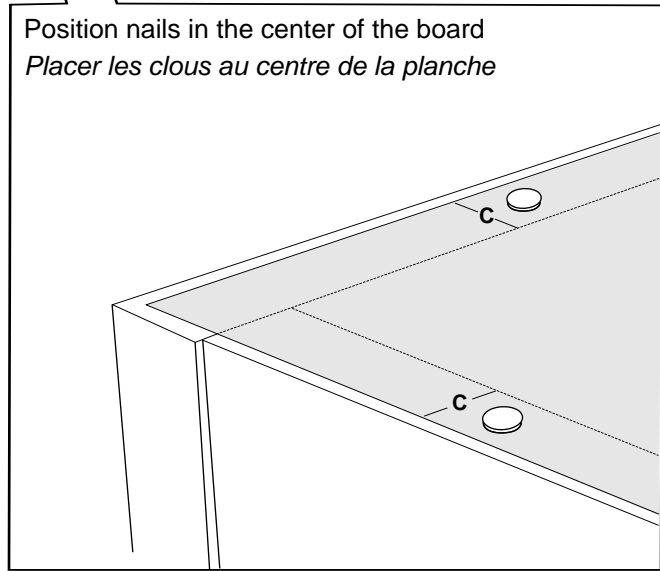
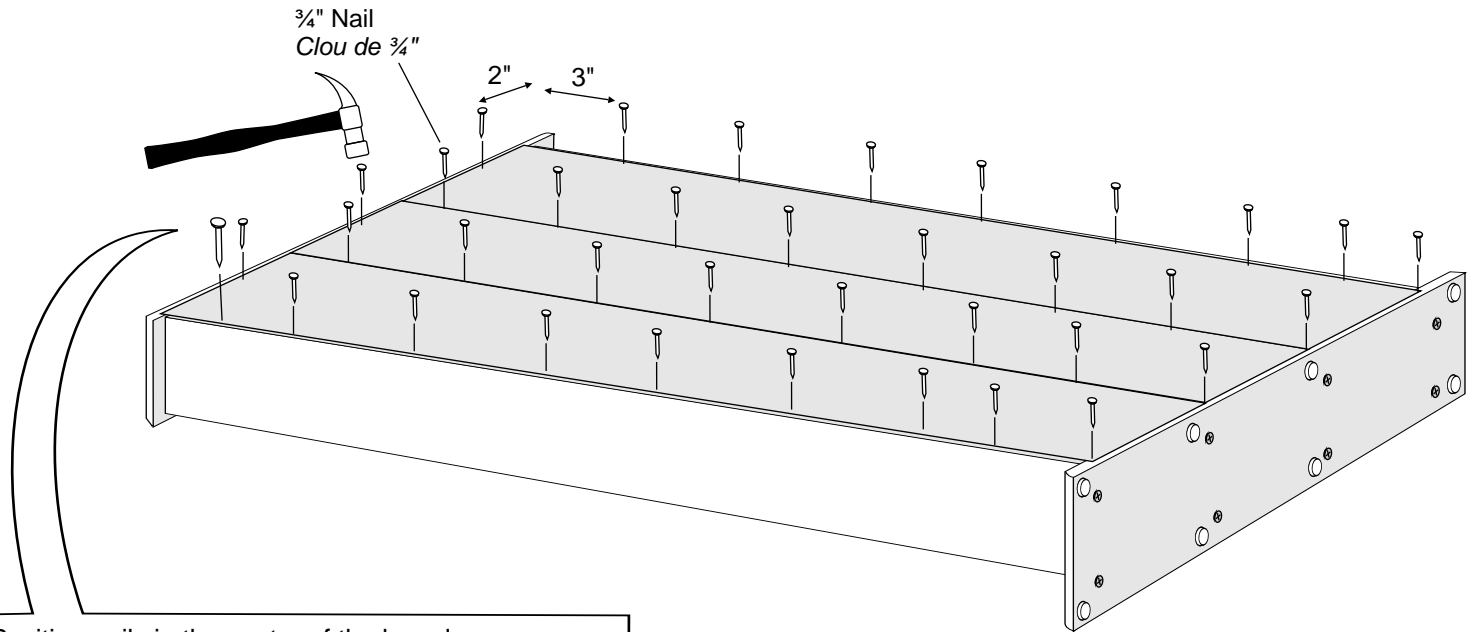

- 9.** Insert metal dowels into shelf holes and add shelves.  
 Insérez les goujons de métal dans les trous des tablettes et posez les tablettes.

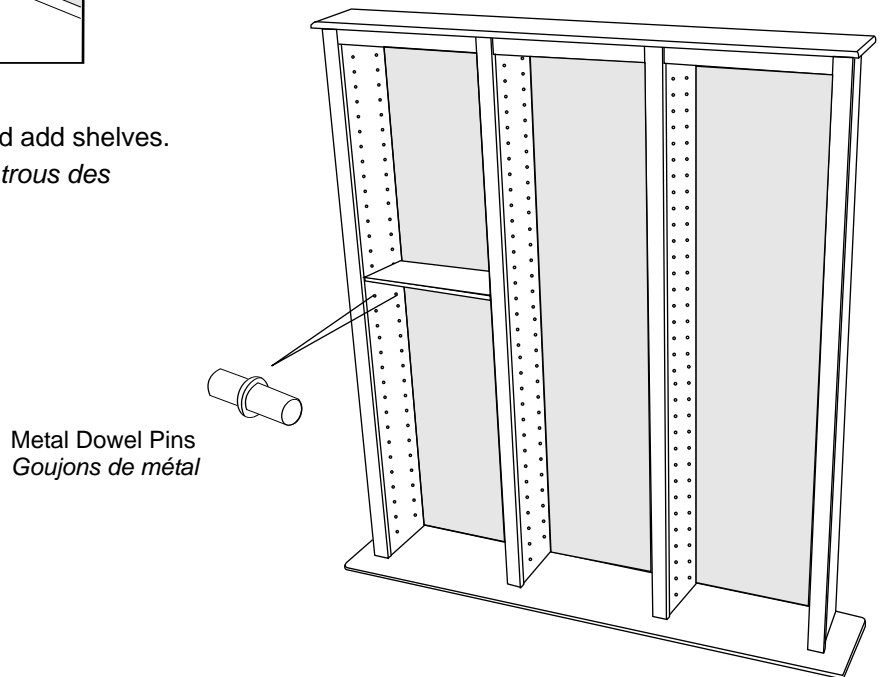

Secure media tower to wall using the Cable Ties (see next step for details)

Fixez le produit au mur en utilisant l'attache pour câble (voir la prochaine étape pour des détails)

- 10.** With the #6- $\frac{3}{4}$ " screw, attach one of the mounting bases to one of the gables 1 inch from the top.  
*Avec #6 le  $\frac{3}{4}$  " vis, attachez un des bases de support à un des pignons un pouce à partir du dessus.*

- 11.** Attach the 2nd mounting base to the wall 2" lower than the one on the cabinet  
**Important:** Find a wall stud and attach the mounting base with a  $\frac{1}{2}$ " screw (not included). If you cannot locate a stud, use an approved wall mounting system  
*Attachez le 2ème base de support au mur 2 " inférieurs à celui sur le module.*  
**Important:** Trouvez un goujon de mur et attachez la base de support avec la vis  $\frac{1}{2}$ " (non inclus). Si vous ne pouvez pas localiser un goujon, utilisez un système approuvé de support de mur.

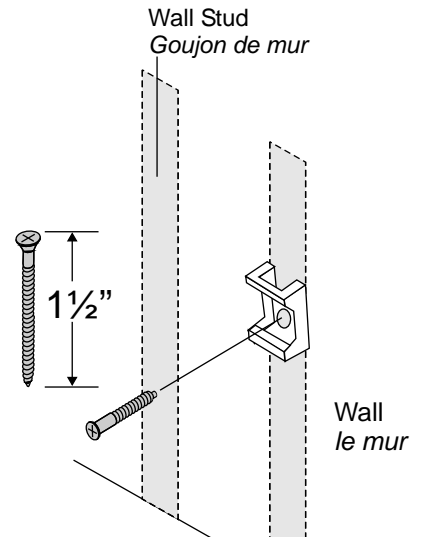
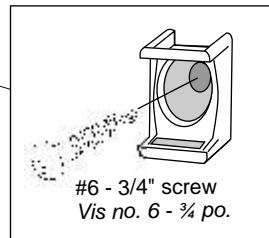
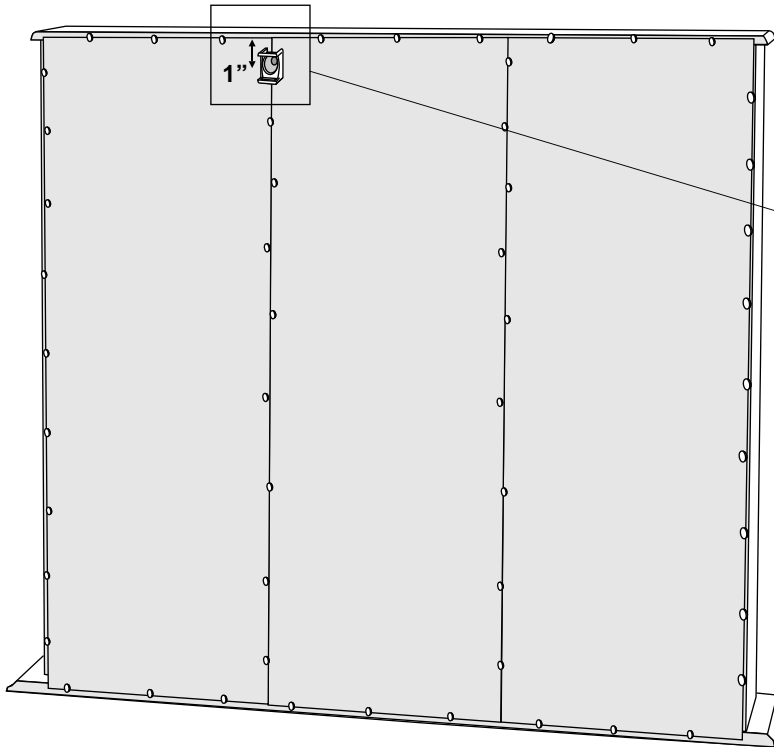

We recommend you screw into a stud. If you cannot locate a stud use a wall anchor appropriate for your type of wall.

*Nous vous recommandons vis dans un goujon. Si vous ne pouvez pas localiser une utilisation de goujon une ancre de mur appropriée pour votre type de mur.*

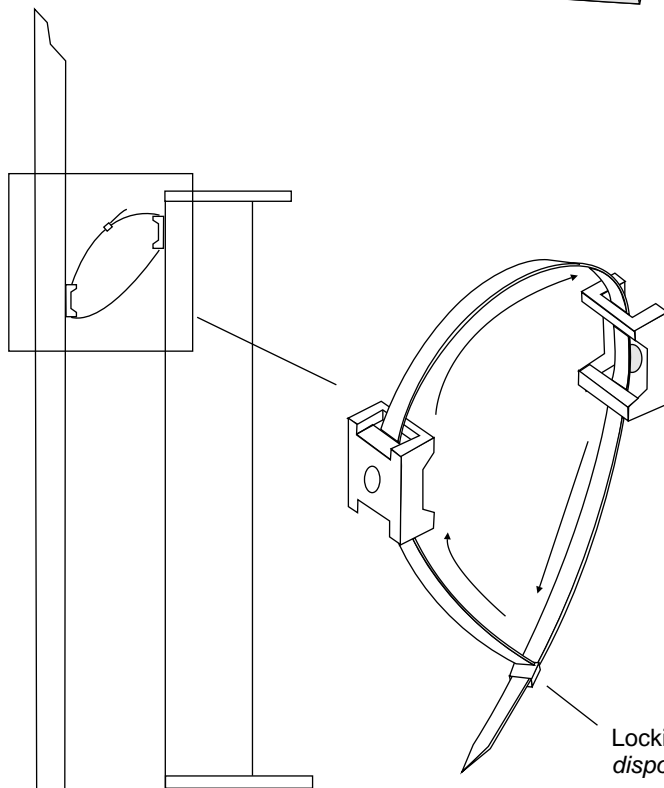

- 12.** Feed the cable tie through each mounting base and then through the locking mechanism to tighten.  
*Alimentez le serre-câble par chaque base de support et alors par le dispositif de verrouillage pour serrer.*

### Furniture Care

- Q. How do I clean your products?**  
**A.** We recommend that you simply wipe your products with a clean, damp cloth and then dry immediately with another clean cloth to maximize the life span and look of your unit
- Q. Can I paint or varnish your products?**  
**A.** Our products are made from durable composite woods with a laminate finish and therefore should not be painted or varnished.
- Q. Are they waterproof?**  
**A.** NO. If liquid is spilled and quickly wiped up, no damage will be done to your product. However, continuous exposure to liquids or high humidity may cause damage to the board.

### Soin de meubles

- Q. Comment est-ce que je nettoie vos produits ?**  
**A.** Nous recommandons que vous essuyez simplement vos produits avec un propre, tissu humide et puis séchons immédiatement avec un autre tissu propre pour maximiser la durée et le regard de votre unité
- Q. Est-ce que je peux peindre ou vernir vos produits ?**  
**A.** Nos produits sont faits à partir des bois composés durables avec une finition en stratifié et ne devraient pas donc être peints ou vernis.
- Q. Sont-ils imperméables à l'eau ?**  
**A.** NO. Si le liquide est renversé et rapidement essuyé vers le haut, aucun dommage ne sera fait à votre produit. Cependant, l'exposition continue aux liquides ou le humidité élevé peut endommager le conseil.

### Give Us Your Feedback



### CALL US

1-877-PREPAC1 (1-877-773-7221)  
Mon - Fri 7am - 4pm PST  
10am - 7pm EST

Email Us: [assembly@prepacmfg.com](mailto:assembly@prepacmfg.com)

# Thanks!