

28 287

Relexa^{plus}

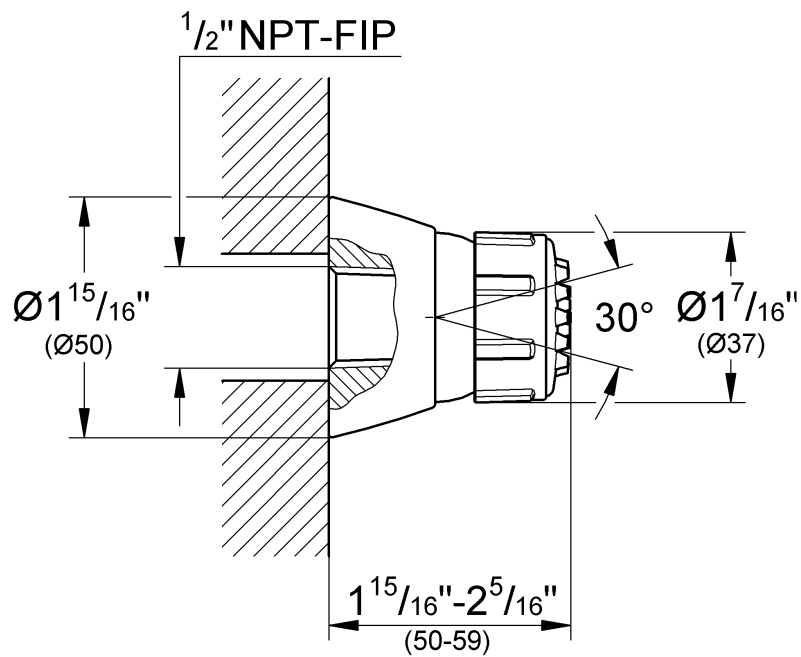
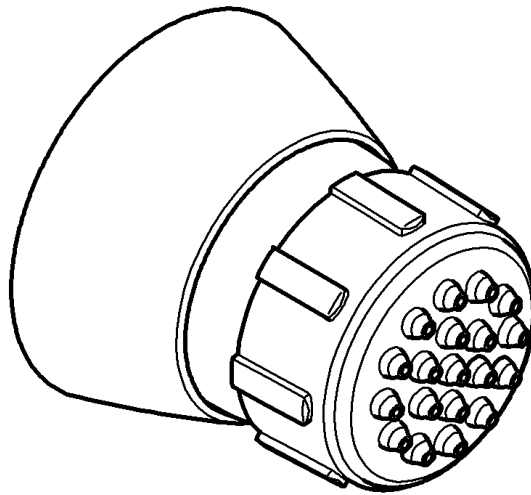

Relexa^{plus}

English3

Français3

Español3

Design & Quality Engineering GROHE Germany



95.081.231/ÄM 41 511/10.10

ENJOY WATER®

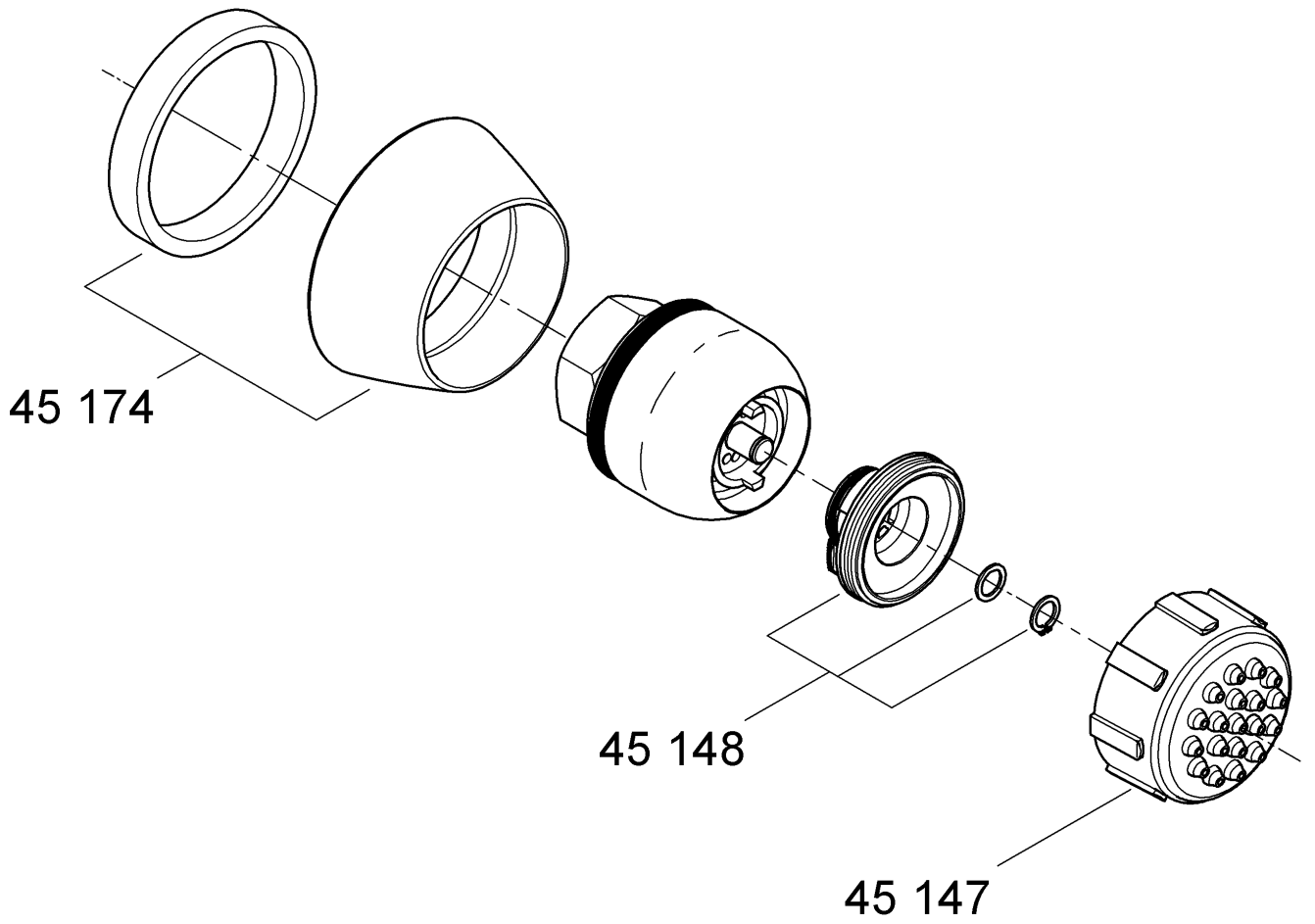

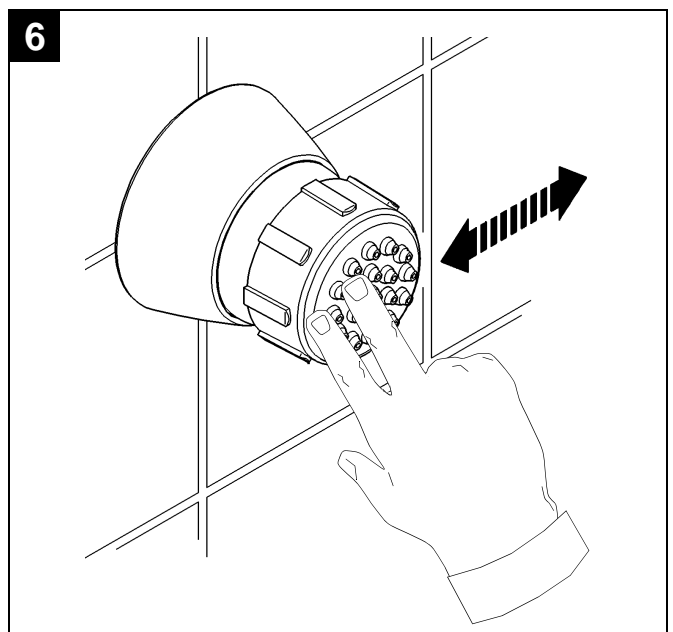
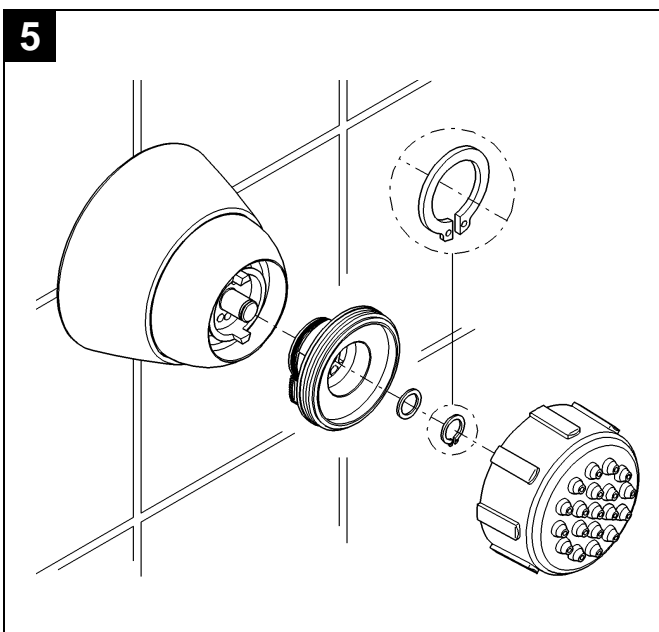
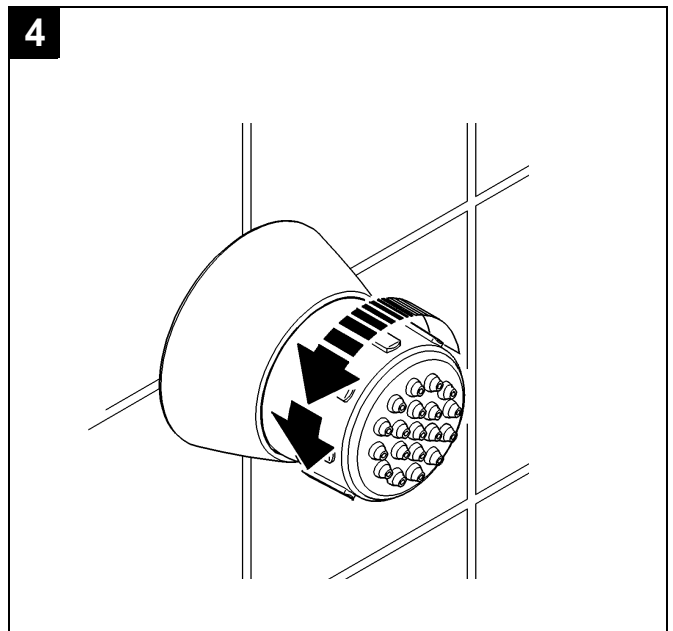
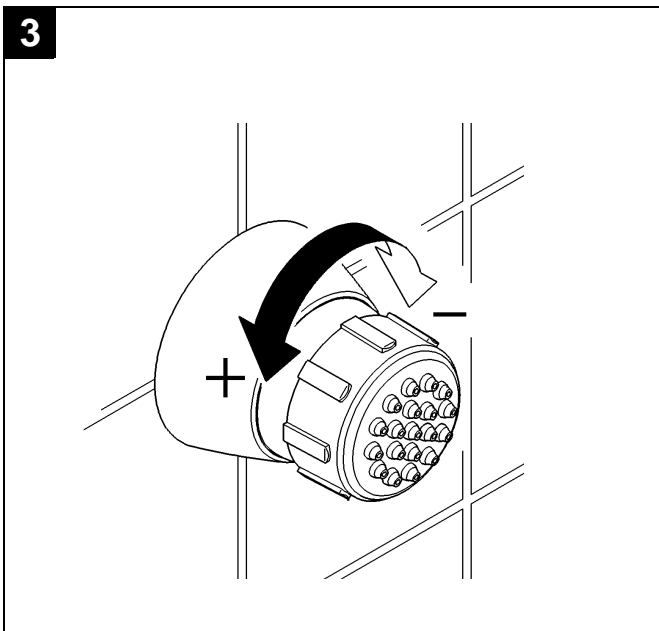
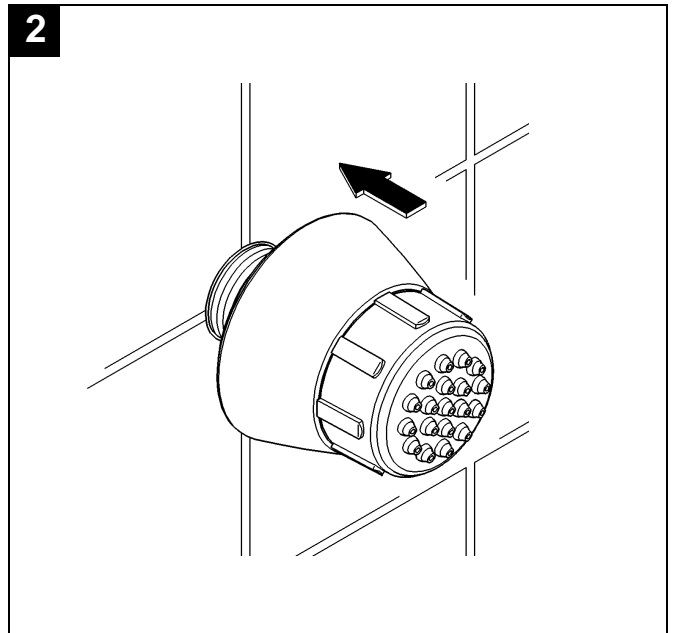
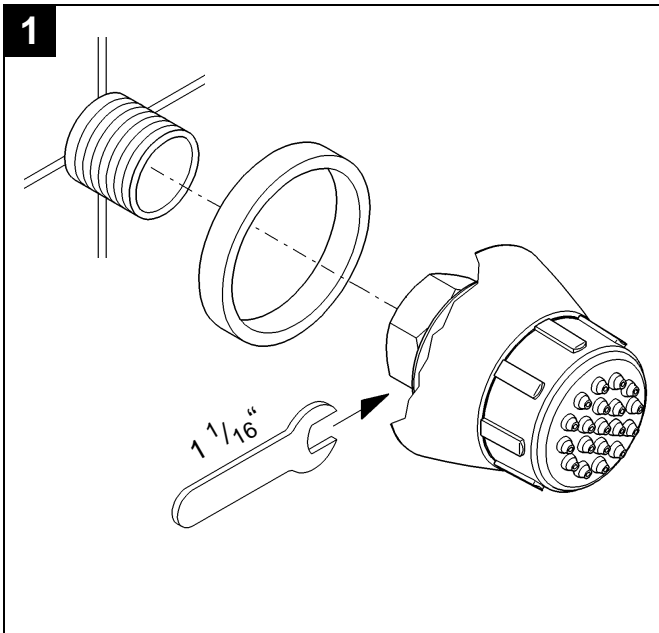

English

Specification

- Max. flow 9,5 L/min or 2,5 gpm/ 80 psi

Installation, see figs. [1] and [2].

Flow adjustment, see fig. [3].

Disassembly, see figs. [4] and [5].

Maintenance (Quick descaling), see fig. [6].

Guaranteed for 5 years, the “SpeedClean” jets can be freed of limescale simply by wiping across them firmly with the palm of your hand.

- To be installed according to local codes and regulations.

Français

Caractéristiques techniques

- Débit maxi. 9,5 l/min ou 2,5 g/min/ 5,5 bar

Installation, voir fig. [1] et [2].

Ajustement du débit, voir fig. [3].

Démontage, voir fig. [4] et [5].

Maintenance (Detartrage rapide), voir fig. [6].

Les dépôts de calcaire s'éliminent par simple passage de la main sur les buses.
5 ans de garantie sur le fonctionnement des buses SpeedClean.

- Il faut que ce soit installé conformément aux lois et prescriptions locales.

Español

Datos técnicos

- Caudal máx 9,5 L/min o 2,5 gpm/ 80 psi

Instalación, véanse las figs. [1] y [2].

Regulador de caudal, véase la fig. [3].

Desmontaje, véanse las figs. [4] y [5].

Mantenimiento (Descalcificación rápida) véase la fig. [6].

5 años de garantía sobre el correcto funcionamiento de los conos anticalcáreos “SpeedClean”. Los sedimentos se eliminan pasando simplemente la mano.

- Tiene que instalarse conforme a las disposiciones legales del lugar.

