

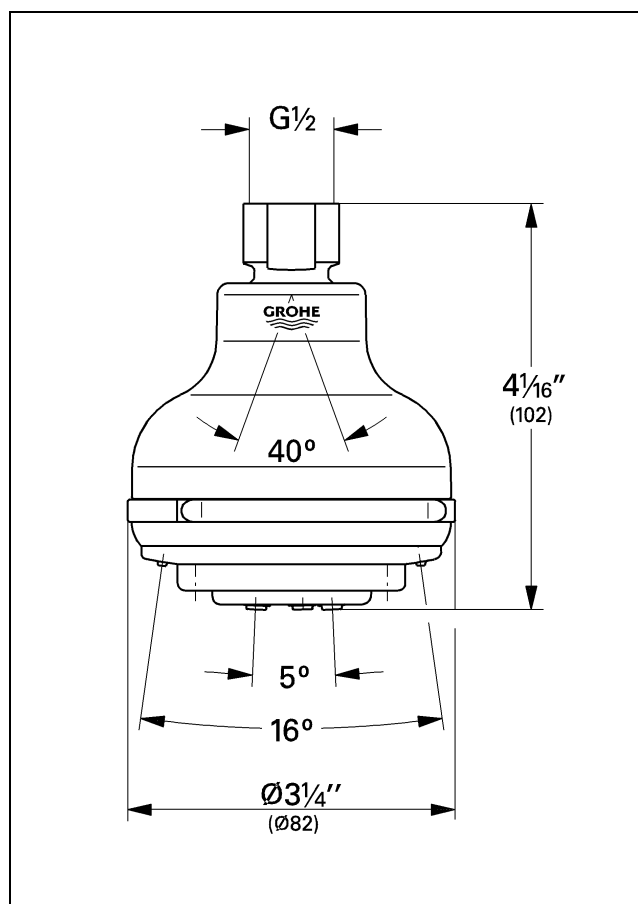

Relaxa^{plus}



28 275

English page 3
Français page 3
Español página 3

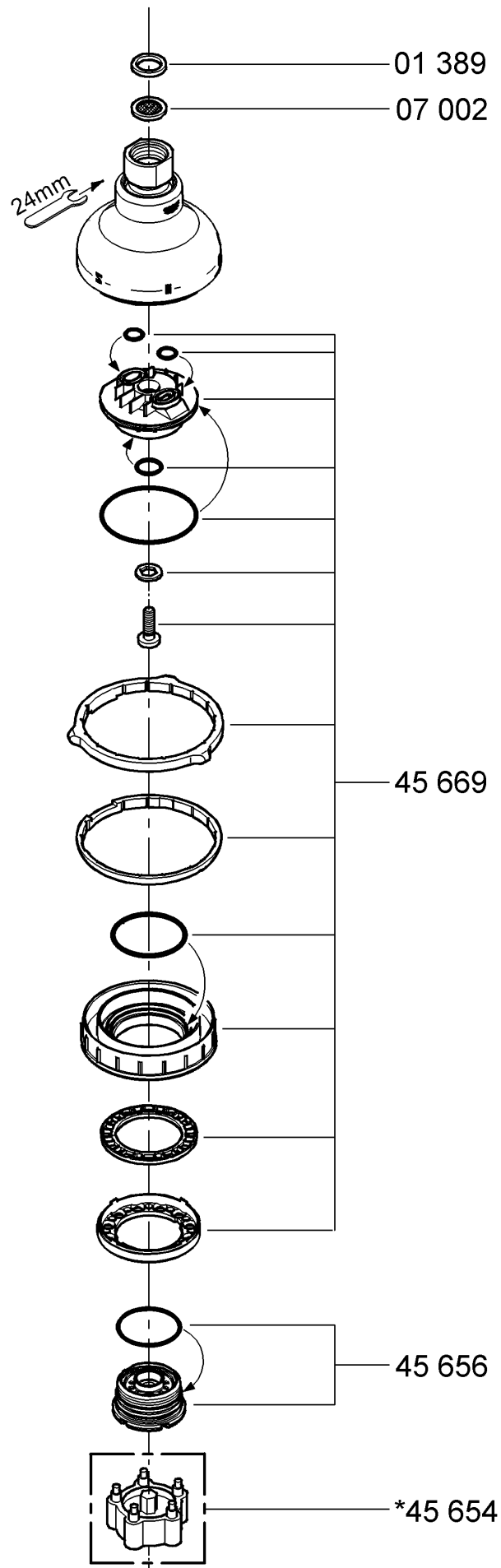

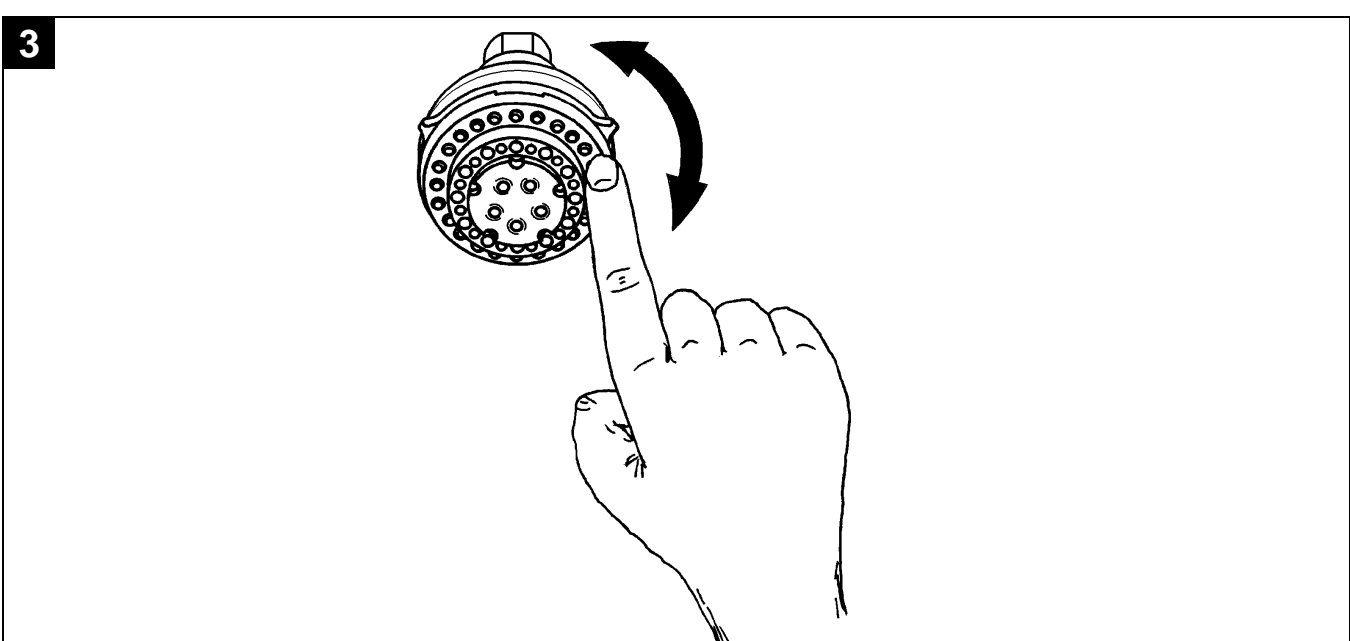
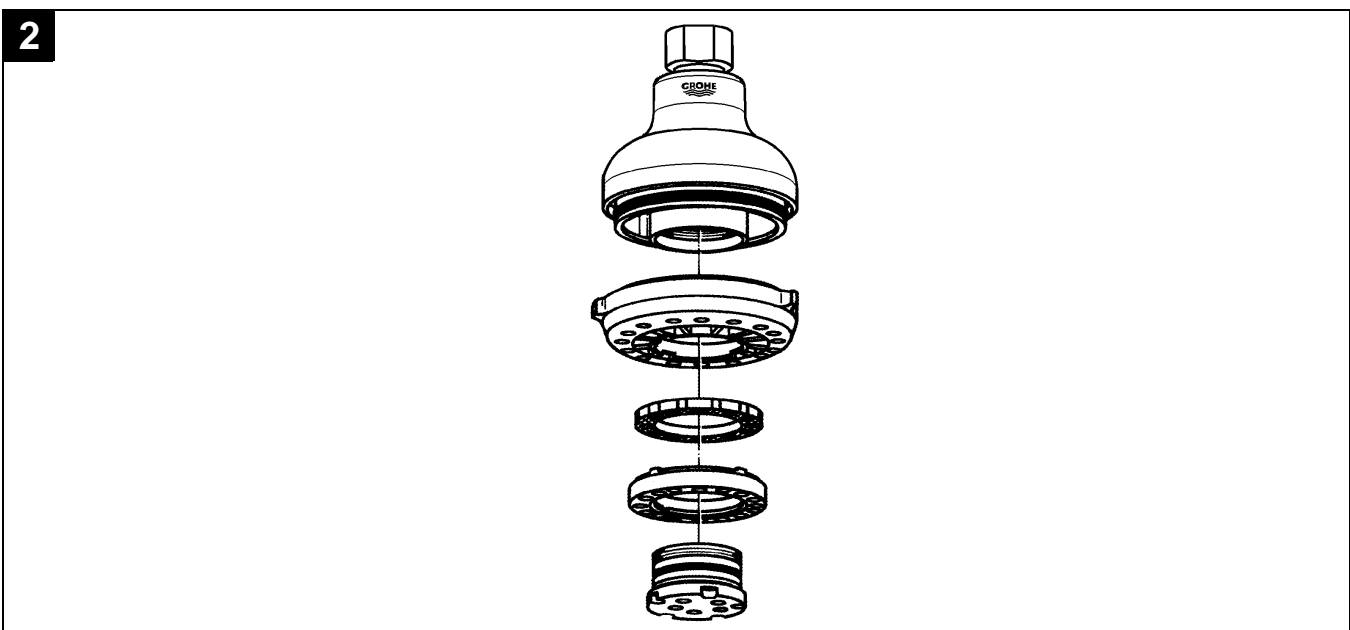
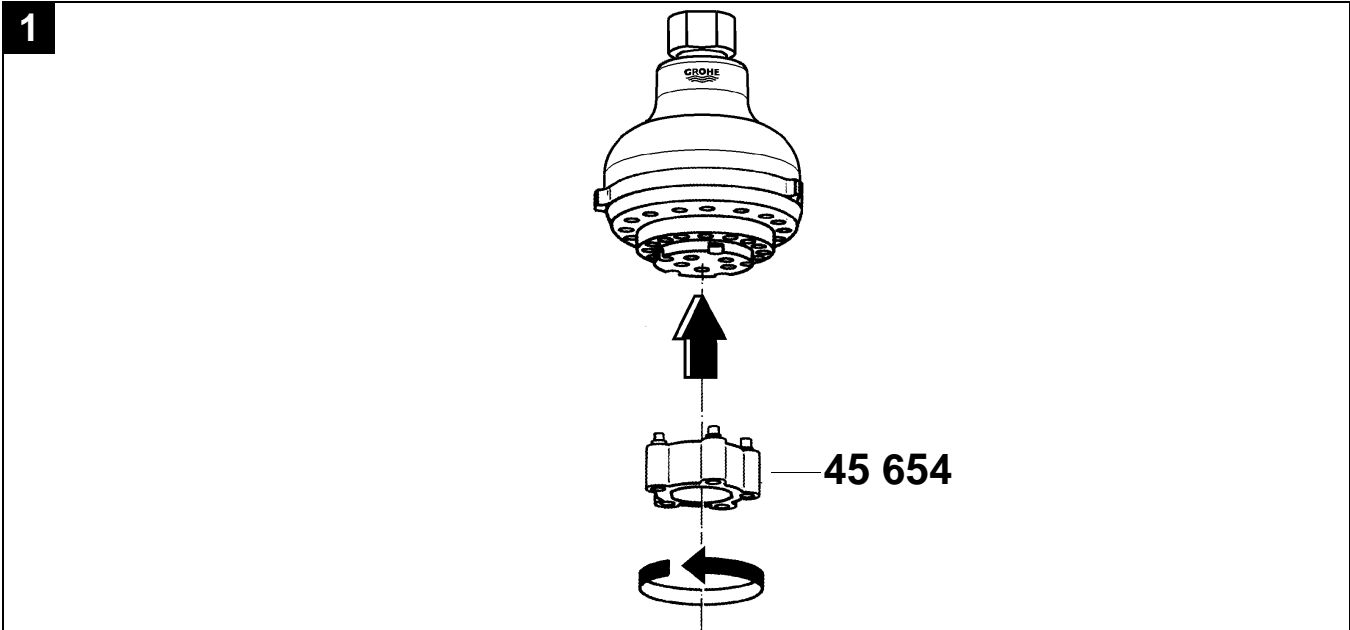

English

Technical data

- Max. flow 9,5 L/min or 2,5 gpm/ 80 psi

Installation

To be installed according to local codes and regulations.

Maintenance

Disassembly, see figs. [1] and [2].

Maintenance (quick descaling), see fig. [3].

We guarantee that the SpeedClean nozzles will continue to function for a period of five years. Simply rub nozzles in order to remove limescale.

Replacement parts, see fold-out page 1 (* = special accessories).

Français

Caractéristiques techniques

- Débit maxi. 9,5 l/min ou 2,5 g/min/ 5,5 bar

Installation

Il faut que ce soit installé conformément aux lois et prescriptions locales.

Maintenance

Démontage, voir fig. [1] et [2].

Maintenance (détartrage rapide), voir fig. [3].

Les buses SpeedClean sont garanties 5 ans. Les dépôts de tartre sont supprimés par simple frottement des doigts ou d'une éponge.

Pièces de rechange, voir volet 1 (* = accessoires spéciaux).

Español

Datos técnicos

- Caudal máx 9,5 L/min o 2,5 gpm/ 80 psi

Instalación

Tiene que instalarse conforme a las disposiciones legales del lugar.

Mantenimiento

Desmontaje, véanse la figs. [1] y [2].

Mantenimiento (descalcificación rápida) véase la fig. [3].

Los conos SpeedClean tienen 5 años de garantía en cuanto a funcionamiento estable. Los depósitos calcáreos se eliminan simplemente a base de frotar.

Repuestos, véase la página desplegable 1 (* = accesorios especiales).

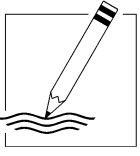

A series of 20 horizontal lines spaced evenly down the page, providing a template for handwriting practice. The lines are solid black and extend across most of the page width.

