

PORCHER® INSTALLATION INSTRUCTIONS

Lutezia/Pomezia Elongated & Round Front Two-Piece Toilet

Models 9015X, 9016X, 9028X, 9035X

Thank you for selecting Porcher - the benchmark of fine quality for over 100 years. To ensure this product is installed properly, please read these instructions carefully before you begin. (Certain installations may require professional help.) Also be sure your installation conforms to local codes.

⚠ CAUTION: PRODUCT IS FRAGILE. TO AVOID BREAKAGE AND POSSIBLE INJURY HANDLE WITH CARE!

NOTE: Pictures may not exactly define contour of china and components.

RECOMMENDED TOOLS AND MATERIALS

Putty Knife	Regular Screwdriver	Adjustable Wrench	Sealant	Tape Measure
Hacksaw	Wax Ring/Gasket	Flexible Supply Tube	Closet Bolts	Carpenters Level

1 REMOVE OLD TOILET

- Close toilet supply valve and flush tank completely. Towel or sponge remaining water from tank and bowl.
 - Disconnect and remove supply line. NOTE: *If replacing valve, first shut off main water supply!*
 - Remove old mounting hardware, remove toilet and plug floor waste opening to prevent escaping sewer gases.
 - Remove closet bolts from flange and clean away old wax, putty, etc. from base area.
- NOTE: *Mounting surface must be clean and level before new toilet is installed!*

2 ROUGHING-IN DIMENSIONS:

ELONGATED

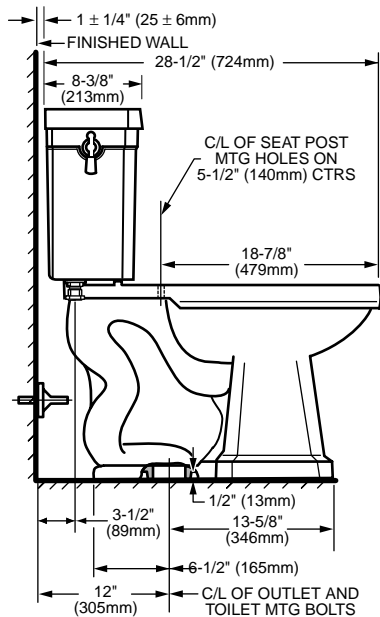

ROUND FRONT

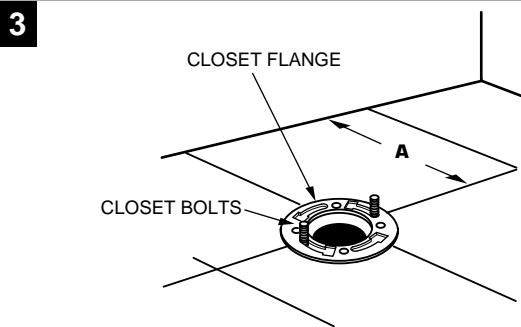
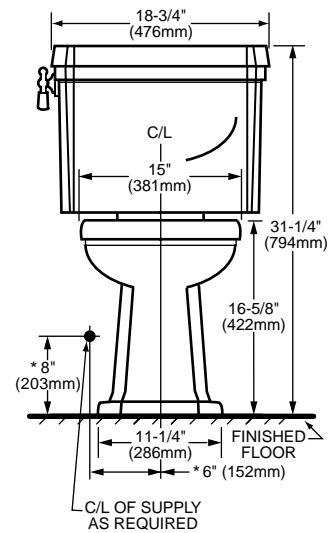
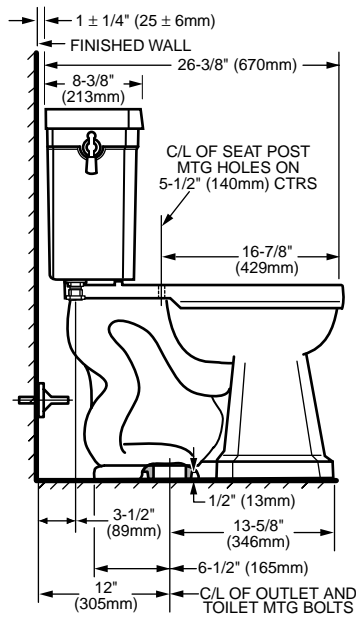

INSTALL CLOSET BOLTS

Install closet bolts in flange channel, turn 90°, and slide into place 6" (152 mm) apart and parallel to wall.

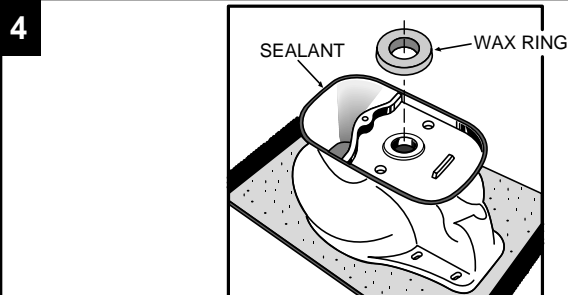

INSTALL WAX SEAL

Invert toilet on floor (cushion to prevent damage), and install wax ring evenly around waste flange (horn), with tapered end of ring facing toilet. Apply a thin bead of sealant around toilet base.

SAVE FOR FUTURE USE

5

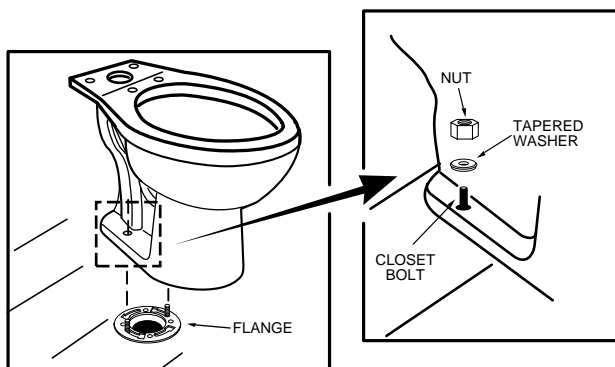

POSITION TOILET ON FLANGE

- Unplug floor waste opening and install toilet on closet flange so bolts project through mounting holes.
- Loosely install retainer washers and nuts. Side of washers marked "THIS SIDE UP" must face up!

6

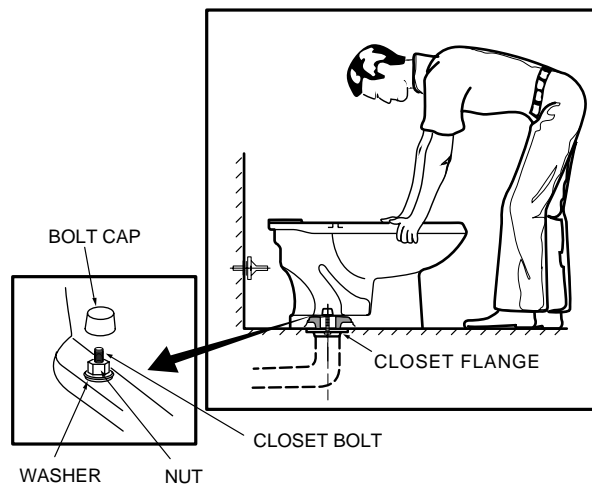

INSTALL TOILET

- Position toilet squarely to wall and, with a rocking motion, press bowl down fully on wax ring and flange. Alternately tighten nuts until toilet is firmly seated on floor.

CAUTION:

DO NOT OVERTIGHTEN NUTS OR BASE MAY BE DAMAGED!

- Install caps on washers. (If necessary, cut bolt height to size before installing caps.)
- Smooth off the bead of sealant around base. Remove excess sealant.

7

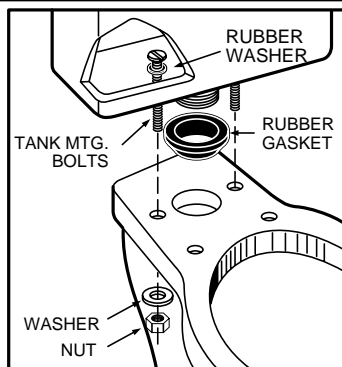

INSTALL TANK

- Install large rubber gasket over threaded outlet on bottom of tank and lower tank onto bowl so that tapered end of gasket fits evenly into bowl water inlet opening.
- Insert tank mounting bolts and rubber washers from inside tank, through mounting holes, and secure with metal washers and nuts.
- With tank parallel to wall, alternately tighten nuts until tank is snugged down evenly against bowl surface.

CAUTION:

DO NOT OVERTIGHTEN NUTS MORE THAN REQUIRED FOR A SNUG FIT!

8

INSTALL TOILET SEAT Install toilet seat in accordance with manufacturer's directions.

9a

Before continuing, determine the type of water supply connection you have from the chart below and use the appropriate assembly parts required to properly reconnect the water supply. **DO NOT** use plumber's putty to seal these fittings.

METAL/COPPER FLARED TUBING

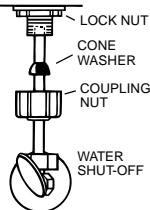

These parts must be used as illustrated to insure water-tight connection. Use of existing coupling nut may result in water leakage. Water supply tube or pipe must extend at least 1/2" inside threaded shank of valve (does not apply to flanged tubing).

CAUTION: DO NOT USE CONE WASHER WITH PLASTIC SUPPLY LINE.

METAL FLANGED TUBING

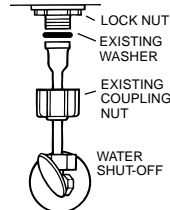

Use existing coupling nut and washer.

METAL SPIRAL TUBING

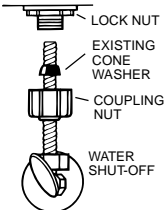

Use existing spiral cone washer. Fluidmaster cone washer may not seal completely on spiral type supply line.

CAUTION: Overtightening of LOCK NUT or COUPLING NUT could result in breakage and potential flooding.

VINYL/BRAIDED CONNECTOR

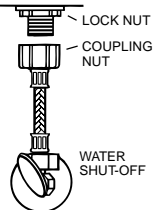

Captive cone washers already included. No additional washers needed.

9b

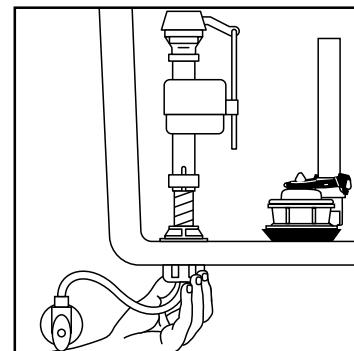

With correct washers in place (see Step 10a), tighten COUPLING NUT 1/4 turn beyond hand tight. **DO NOT OVERTIGHTEN.**

10

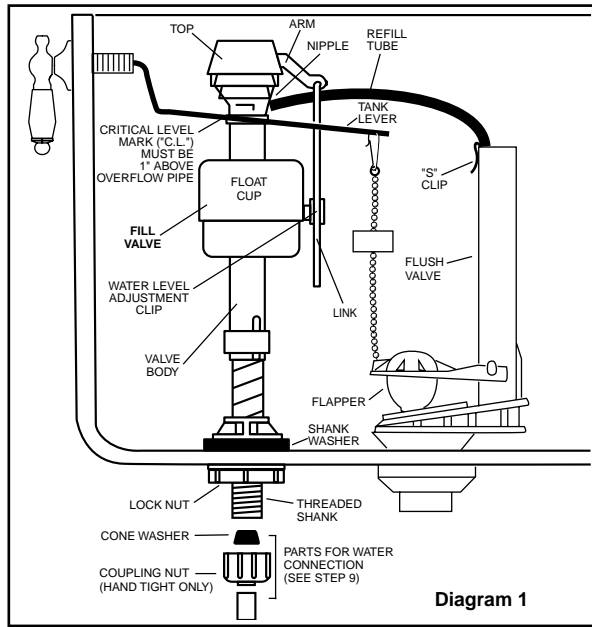

Diagram 1

ADJUSTMENTS

- a. Adjust water level. Water level should be adjusted to level indicated on tank by adjusting float cup.

See Step 11 for water level adjustment method
- b. If bowl fails to siphon, an adjustment may be required with the lift chain. Simply remove the bead chain from the retainment clip (see Fig. 10A) and take up slack on the chain, and reinsert on lift rod. Make sure the chain is not too taught.

11

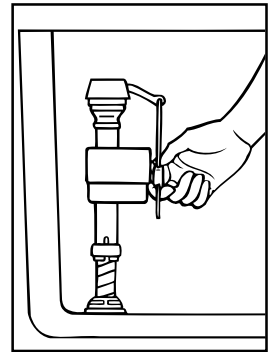

Turn on water supply. Adjust water to desired level by squeezing water level adjustment clip and moving FLOAT CUP up or down along stainless steel link.

12 CARE AND CLEANING

When cleaning your toilet, wash it with mild, soapy water, rinse thoroughly with clear water and dry with a soft cloth. Avoid detergents, disinfectants, or cleaning products in aerosol cans. NEVER use abrasive scouring powders or abrasive pads on your toilet seat. Some bathroom chemicals and cosmetics may damage the seat's finish.

! WARNING: Do not use in-tank cleaners. Products containing chlorine (calcium hypochlorite) can seriously damage fittings in the tank. This damage can cause leakage and property damage.
Porcher shall not be responsible or liable for any tank fitting damage caused by the use of cleaners containing chlorine (calcium hypochlorite).

REPAIR PARTS LIST

Repair parts are determined by toilet tank number which can be found marked inside tank.

NOTE: "XXX" represents color or trim finish options. Specify when ordering.

INDEX NO.	PART NO.	DESCRIPTION	QTY. USED	90150	90152	90155	90160	90162	90165	90280	90282	90285	90350	90352	90355
1	41150.00.001	POMEZIA TANK ASSEMBLY COMPLETE W/CHROME TRIP LEVER	1	X									X		
	41152.00.001	POMEZIA TANK ASSEMBLY COMPLETE W/POLISHED BRASS TRIP LEVER	1		X									X	
	41155.00.001	POMEZIA TANK ASSEMBLY COMPLETE W/BRUSHED NICKEL TRIP LEVER	1			X									X
	41160.00.001	LUTEZIA TANK ASSEMBLY COMPLETE W/CHROME TRIP LEVER	1				X			X					
	41162.00.001	LUTEZIA TANK ASSEMBLY COMPLETE W/POLISHED BRASS TRIP LEVER	1					X			X				
	41165.00.001	LUTEZIA TANK ASSEMBLY COMPLETE W/BRUSHED NICKEL TRIP LEVER	1						X			X			
2	80150.00.001	POMEZIA COVER TANK	1	X	X	X							X	X	X
	80160.00.004	LUTEZIA COVER TANK	1				X	X	X	X	X	X			
3	80150.00.000	TRIP LEVER ASSEMBLY, CHROME (W/ BEZEL & MTG HARDWARE)	1	X		X				X			X		
	81052.00.000	TRIP LEVER ASSEMBLY, POLISHED BRASS (W/ BEZEL & MTG HRDWRE)	1		X		X				X			X	
	81055.00.000	TRIP LEVER ASSEMBLY, BRUSHED NICKEL (W/ BEZEL & MTG HRDWRE)	1			X			X			X			X
4	83020.00.000	FLUSH VALVE ASSEMBLY (W/FLAPPER ASSY, GASKET, AND NUT)	1	X	X	X	X	X	X	X	X	X	X	X	X
5	84150.00.000	WATER CONTROL ASSEMBLY (W/ MTG HARDWARE)	1	X	X	X	X	X	X	X	X	X	X	X	X
6	230-C	KIT, COUPLING, BOWL/TANK (W/ GASKET & MTG HARDWARE)	1	X	X	X	X	X	X	X	X	X	X	X	X
7	82010.00.001	BOLT CAP	1	X	X	X	X	X	X	X	X	X	X	X	X
8	40150.00.001	BOWL, ELONGATED	1	X	X	X	X	X	X						
	40280.00.000	BOWL, ROUND FRONT	1							X	X	X	X	X	X

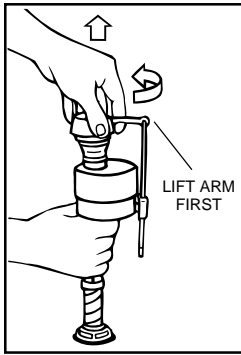

IMPORTANT: Always clear sand and rust from system.

- Make sure water supply is off. Remove valve TOP by lifting arm and rotating top and arm 1/8 turn counterclockwise, pressing down slightly on cap.



- While holding a container over the uncapped VALVE to prevent splashing, turn water supply on and off a few times. Leave water supply off.

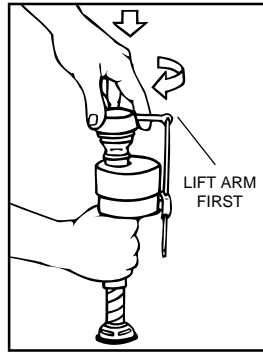

- Replace TOP by engaging lugs and rotating 1/8 turn clockwise. **MAKE CERTAIN TIP IS TURNED TO THE LOCKED POSITION. VALVE MAY NOT TURN ON IF TOP IS NOT FULLY TURNED TO THE LOCKED POSITION.**

TROUBLESHOOTING FILL VALVE

IF FILL VALVE SHUTS OFF BUT CONTINUES TO LEAK SLOWLY, repeat Step 13.

IF FILL VALVE TURNS OFF AND ON DURING PERIODS OF NON-USE, it is a signal you are wasting water because:

- The end of the refill tube is inserted into overflow pipe, below water level in tank. Attach refill tube to overflow pipe using "S" clip provided.
- The flush valve is leaking because it's worn, dirty or misaligned with tank ball or flapper (replace with a new flapper).

IF FILL VALVE WON'T TURN ON OR SHUT OFF or REFILL OF TANK WATER IS SLOW after valve has been in use for some time, Fluidmaster Model 242 Replacement Seal may be needed.

For troubleshooting information please contact:



30800 Rancho Viejo Road
San Juan Capistrano, CA 92675
(949) 728-2000 (800) 631-2011
www.fluidmaster.com

© 2001 Fluidmaster, Inc.
® Registered trademark of Fluidmaster, Inc.

GUARANTEE: This Fluidmaster product is guaranteed to be free from defective materials and workmanship for a period of one year. Units returned to Fluidmaster will be replaced without charge.

Always use quality Fluidmaster repair parts when maintaining your Fluidmaster products. Fluidmaster shall not be responsible or liable for any damages caused by products used with Fluidmaster valves that were not manufactured by Fluidmaster, Inc.

TROUBLESHOOTING GUIDE

PROBLEM	POSSIBLE CAUSE	CORRECTIVE ACTION
Does not flush	a. Water supply valve closed.	a. Open valve and allow water to fill tank.
	b. Supply line blocked.	b. Shut off water supply, disconnect supply line, and inspect all gaskets and washers. Reassemble. Also, see Fluidmaster maintenance (see step 13).
	c. Flush valve chain too loose or disconnected.	c. Readjust chain length as required.
	d. Sand or debris lodged in water control.	d. Shut off water supply. Remove cap and clean per Step 13.
Poor or sluggish flush	a. Bowl water level too low.	a. Check that refill tube is connected to water control and inserted into tank overflow without being kinked or damaged.
	b. Supply valve partly closed.	b. Open supply valve fully. Be sure that proper supply tube size is used.
	c. Partially clogged trapway and/or drain pipe and/or vent.	c. Remove obstruction. Consult a plumber if necessary.
	d. Supply pressure too low.	d. Normal supply pressure must be at least 20 psi.
Toilet leaks	a. Poor supply line connection.	a. Review Step 9 of installation procedure.
	b. Poor bowl to tank/floor connection.	b. Review Step 4 through 7 of installation procedure.
Toilet does not shut off	a. Flush valve chain too tight, holding flush valve open.	a. Readjust chain length as needed. Review step 10.
	b. Flush valve seat and/or flapper worn or deformed.	b. Replace flapper/flush valve assembly, as needed.
	c. Sand or debris lodged in water control.	c. Shut off water supply. Remove cap and clean per Step 13.

PORCHER ONE-YEAR LIMITED WARRANTY

If inspection of this Porcher plumbing product, within one year after its initial purchase, confirms that it is defective in materials or workmanship, Porcher will repair or, at its option, exchange the product for a similar model.

This warranty **does not apply** to local building code compliance. Since local building codes vary considerably, the purchaser of this product should check with a local building or plumbing contractor to insure local code compliance before installation.

This warranty **shall be void** if the product has been moved from its initial place of installation; if it has been subjected to faulty maintenance, abuse, misuse, accident or other damage; if it was not installed in accordance with Porcher's instructions; or if it has been modified in a manner inconsistent with the product as shipped by Porcher.

Porcher's option to repair or exchange the product under this warranty does not cover any labor or other costs of removal or installation, **nor shall Porcher be responsible for any other incidental or consequential damages attributable to a product defect or to the repair or exchange of a defective product, all of which are expressly excluded from this warranty.** (Some states or provinces do not allow the exclusion or limitation of implied warranties, so this exclusion may not apply to you.)

This warranty gives you specific legal rights. You may have other statutory rights that vary from state to state or from province to province, in which case this warranty does not affect such statutory rights.

For service under this warranty, it is suggested that a claim be made through the contractor or dealer from or through whom the product was purchased, or that a service request (including a description of the product model and of the defect) be sent to the following address:

In the United States:
Porcher,
P.O. Box 6820
Piscataway, New Jersey 08855
Attention: Director of Consumer Affairs

In Canada:
Porcher,
2480 Stanfield Rd.,
Mississauga, Ontario
Canada L4Y 1S2

In Mexico:
Porcher,
Planta Santa Clara
Via Morelos #330
Santa Clara Coatitla
de Morelos 55540
Estado de Mexico, Mexico

For residents of the United States, warranty information may also be obtained by calling the following toll free number: (800) 359-3261

Toll Free: (800) 387-0369