

SERIES "S" SURFACE/RECESS MOUNTED CABINET

General Notes

- Unpack the cabinet and check thoroughly for all hardware and loose parts as follows:
 - Cabinet
 - Shelving
 - Hardware Bag
 - Mounting Bar
 (Do not throw any parts away until install is complete.)
- A square and plumb installation insures proper door operation. A square and level are necessary for proper installation.
- Improper installation voids the warranty. Installed cabinets cannot be returned.
- If you experience any problems with your cabinet contact your dealer or Robern directly.

Robern • 701 N Wilson Ave • Bristol, PA 19007
800 877 2376 • FAX 215 826 9666

Limited Warranty One Year Term







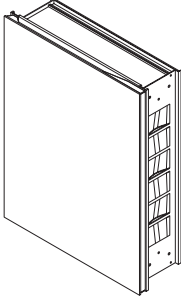
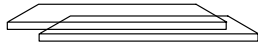

ROBERN warrants to the original purchaser that, it will, at its election repair, replace, or make appropriate adjustment to products made by this company shown to have significant defects in material or workmanship which are reported to ROBERN in writing within one (1) year from the date of delivery. ROBERN is not responsible for installation costs.

The warranty is void in the event the product is damaged in transit, or if damage or failure is caused by abuse, misuse, abnormal usage, faulty installation, damage in an accident, improper maintenance, or any repairs other than those authorized by ROBERN. At the expiration of the one year warranty period, ROBERN shall be under no further obligation under any warranty, expressed or implied, including the implied warranty of merchantability.

ROBERN shall not be liable for any consequential damages arising out of or in connection with the use or performance of its products. Some states do not allow limitations on how long an implied warranty lasts or do not allow the exclusion or limitation of incidental or consequential damages, so the above limitation or exclusion may not apply to you.

Any liability against ROBERN under any implied warranty, including the warranty of merchantability, is expressly limited to the terms of this warranty. Permission to return any merchandise under this warranty must be authorized by ROBERN and returned prepaid by the purchaser. Claims under this warranty should be sent directly to your dealer.

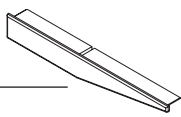
Parts List – Series "S" Cabinet

- Cabinet 
- Glass Shelves
 - 3 Shelves are provided with 26" tall cabinets
 - 2 Shelves are provided with 18" tall cabinets
- Hardware Bag • Contains the Following
 - A. 8 #10 hole plugs 
 - B. 4 #8 hole plugs 
 - C. 4 SMS/wood screws 
 - D. 4 screw head caps 
 - E. 2 mounting clips 
 - F. 2 hingebar endcaps 
 - G. 2 fingerpull endcaps 
 - H. 4 wall anchors 

Cabinet Model #'s & Dimensions

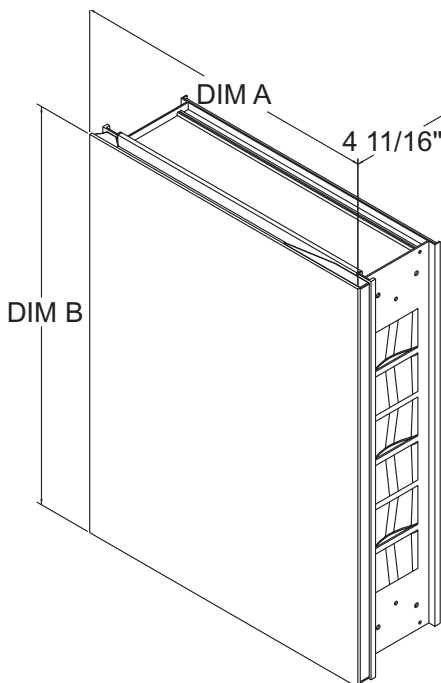

	SEE "DIM A"	SEE "DIM B"	Mirror Type BVS = Bevel FLS = Flat
S	14	18	FLS
S	14	18	BVS
S	14	26	FLS
S	14	26	BVS
S	19	26	FLS
S	19	26	BVS
S	23	26	FLS
S	23	26	BVS

Mounting & Installation

A. Surface Mounting

1. Locate & mark on the wall the center of the cabinet.
2. Locate & drill 2 holes in the mounting bar using a 3/16" drill bit. Holes may be placed inline with a stud for added support.
3. Using the mounting bar as a template & a level, place 2 marks on the wall where holes will be drilled. If no stud is present behind the marks, a 3/16" drill bit will be required to drill a hole for a provided wall anchor to be installed.
4. Attach the mounting bar to the wall using the screws provided. Be sure mounting bar is level.
5. Place & locate cabinet on mounting bar (assistance may be needed, door may also be removed for easier installation). While holding the cabinet, place mounting clip at the top of cabinet as shown in Figure C. Mounting clip should be slid as far to the edge of cabinet as possible. Place a mark thru the hole of the mounting clip. Do the same for the other side. Remove the cabinet from the wall.
6. If no stud is present behind the marks, a 3/16" drill bit will be required to drill a hole for a provided wall anchors to be installed.
7. Place & locate cabinet on mounting bar. Attach mounting clips to the wall using the provided screws.

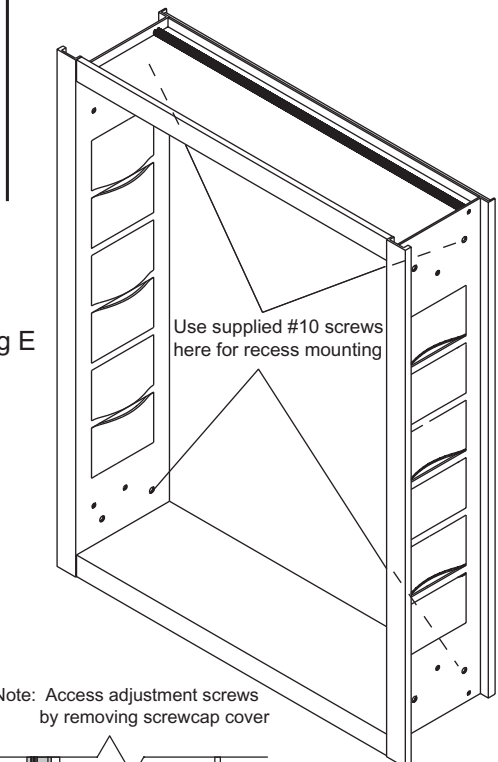
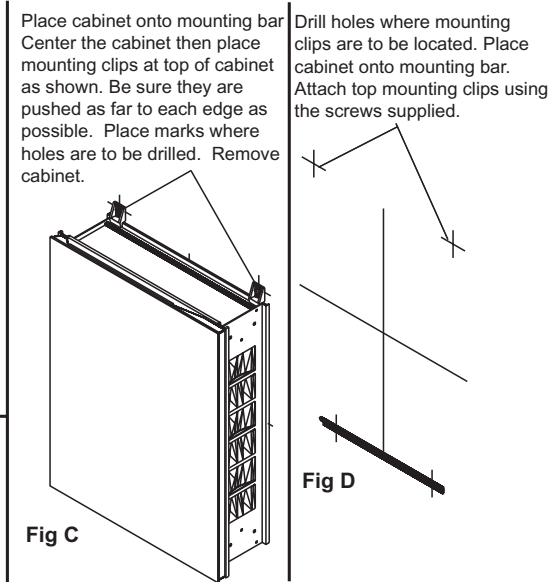
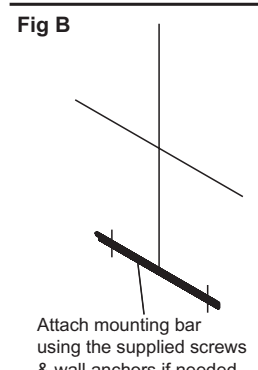
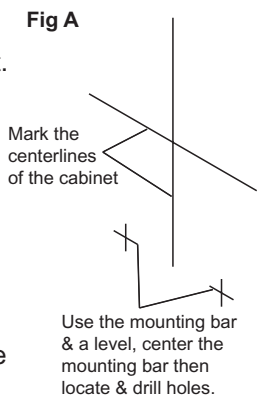

B. Recess Mounting

- Minimum 3 7/8" depth required for recess mounting.
1. See Fig. F for cutout dimensions. Mark the cutout on the wall using a level as a guide.
 2. Cut the wall following the marks on the wall.
 3. 2" x 4" studs should be placed inside to the left & right of the opening. Spacing between studs should be the same as the rough opening.
 4. Place cabinet into recessed opening and secure to the studs thru the holes shown in Fig. E using the #10 screws provided. Screw caps are provided to cover the heads.

C. Shelf Installation

1. Remove the door using the 2 levers on the back of each hinge.
2. Place shelves in the desired location.
3. Replace door by clipping each hinge back on.

D. Installation Completion

1. Place the hingebar & fingerpull endcaps onto each end of the hingebar and fingerpull
2. #8 & #10 holes plugs are provided for unused holes that are inside the cabinet.
3. Adjust the doors to avoid interference as shown in Fig. G.

Fig F

Rough Openings :

- 14" x 18" cabinets = 13 1/2" x 17 1/2" rough opening
- 14" x 26" cabinets = 13 1/2" x 25 1/2" rough opening
- 19" x 26" cabinets = 18 1/2" x 25 1/2" rough opening
- 23" x 26" cabinets = 22 1/2" x 25 1/2" rough opening

Fig G

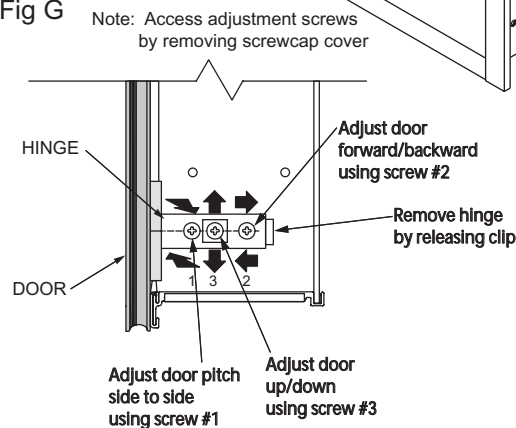

Checklist • Care & Maintenance

1. Cleaning

- A. The cabinet door and interior are constructed of mirror and aluminum. Use only a damp cloth to clean. Mirrors are damaged by the use of ammonia or vinegar based cleaning agents. Use rubbing alcohol for stubborn marks.
- B. Use no abrasive cleansers on any part of the cabinet.