



English

# GUARDIAN ALERT 911™

*Enjoy the Freedom of Independent Living*

## OPERATING INSTRUCTIONS Model No. 30911

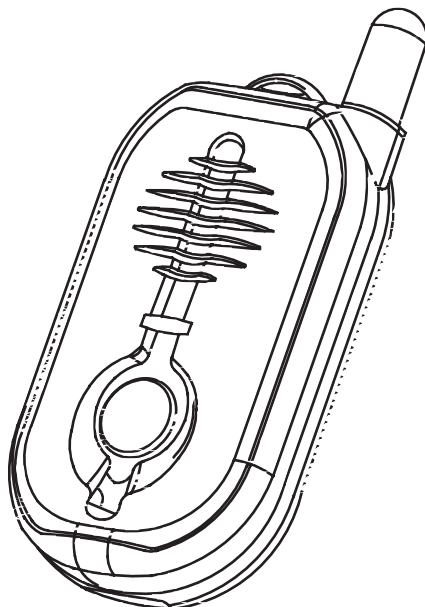

LogicMark

v2.1





**Note: Battery must be installed before use.**

Thank you for choosing the Guardian Alert 911 – your personal link to the 911 emergency operator when you need it.

**PLEASE READ THIS MANUAL COMPLETELY AND SAVE IT FOR REFERENCE.**

**Contents:**

The items below are included with your Guardian Alert 911 . Additional parts or replacements can be ordered from LogicMark, LLC by calling our Customer Service department at 703-934-7934.

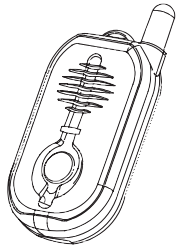

**Pendant**

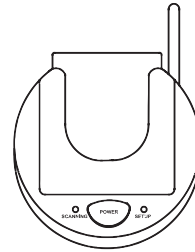

**Base Unit**



**Belt Clip**

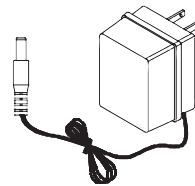

**AC Adapter**

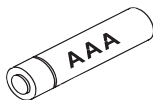

**AAA Alkaline Battery**



**Phone Cord**



**Screwdriver**

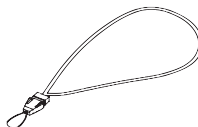

**Lanyard**

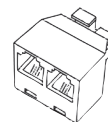

**Line Splitter**





## Optional Accessories:



**Battery Backup #30912**



**Lock Box #30913**

## TABLE OF CONTENTS

<b>Overview of the Guardian Alert 911 .....</b>	<b>4</b>
<b>Installing the Battery .....</b>	<b>5</b>
<b>Locating the Base Unit.....</b>	<b>5</b>
<b>Pendant Features .....</b>	<b>6</b>
<b>Base Unit Features .....</b>	<b>6</b>
<b>Connecting the Guardian Alert 911</b>	
The Standard Connection.....	7
Connecting a Second Phone.....	7
If Your Home Has DSL.....	8
<b>Operating the Guardian Alert 911</b>	
About the Pendant.....	9
Attaching the Lanyard.....	9
Water Resistance .....	9
Battery Check.....	10
System Check.....	11
Emergency Dialing Using the Panic Button .....	12
Hanging Up.....	13
Operating Range .....	13
<b>Troubleshooting Guide .....</b>	<b>14</b>



## Overview Of The Guardian Alert 911:

The Guardian Alert 911 is a tiny cordless speaker phone, small enough to be worn around your neck. It is smaller than most cell phones.

By pressing a single button, the Guardian Alert 911 automatically dials the universal 911 emergency number. You will then be able to speak directly to the 911 operator about your emergency. There is no need to register the product. Simply install it according to these directions and your Guardian Alert 911 is ready.

It has enough range to cover most homes and even into the yard. It is NOT a cell phone, and therefore will not work far from your home. It is designed to be used primarily inside the home. You can use the System Check feature (see page 10) to confirm that the PENDANT is within range of the BASE UNIT.

The Guardian Alert 911 PENDANT has its own replaceable battery. The battery must be installed prior to use. It will last at least 6 to 12 months in standby (or normal use) mode. Because the PENDANT never needs charging, it can be kept with you at all times. We recommend that the PENDANT battery be replaced every six months.

Like most cordless phones, the Guardian Alert 911 must be plugged into a power outlet using an AC adapter (included) to work. An optional battery backup is available which can keep the Guardian Alert 911 BASE UNIT working for up to 24 hours in case of a power failure. It can be ordered from the Customer Service number on the back of this manual. Ask for part number 30912.





## Installing the Battery:

The PENDANT requires one AAA battery. We recommend using a fresh, high quality alkaline or lithium cell from a recognized brand. Under normal use, the battery will last 6 to 12 months. When activated during an emergency, you can talk for up to 30 minutes (depending on battery strength). Follow the diagram to the right to install the battery which came with your kit.

**Insert positive end of battery into the compartment first.**

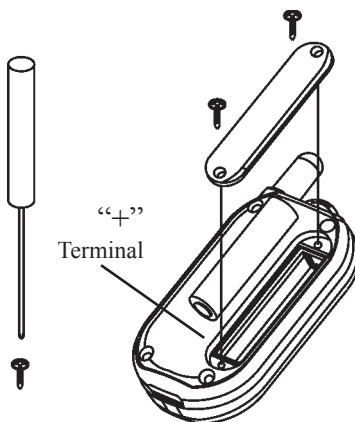

To insure that your Guardian Alert 911 will be ready when you need it, replace the battery every 6 months.

**NOTE:** *The battery cover will only fit easily on the case in one direction.*

## Locating the Base Unit:

For best results and longest range, locate the BASE UNIT in an area away from household appliances which could present electrical interference. These include microwave ovens, televisions, electric mixers or blenders, hairdryers, or other cordless phones.

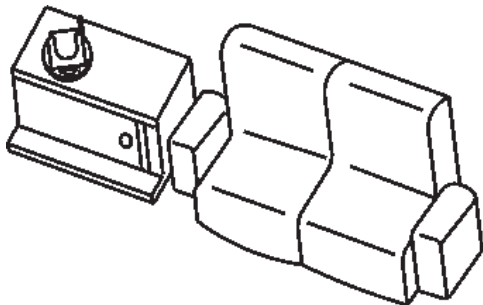

**Good Location**

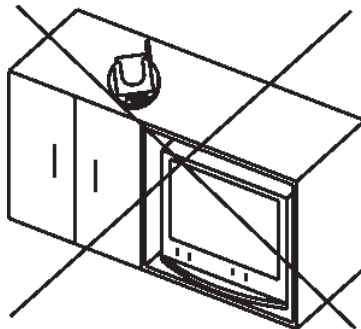

**Bad Location**

If more than one Guardian Alert 911 is to be used in one home, it is recommended that the BASE UNITS be located at least 10' apart.





## Pendant Features:

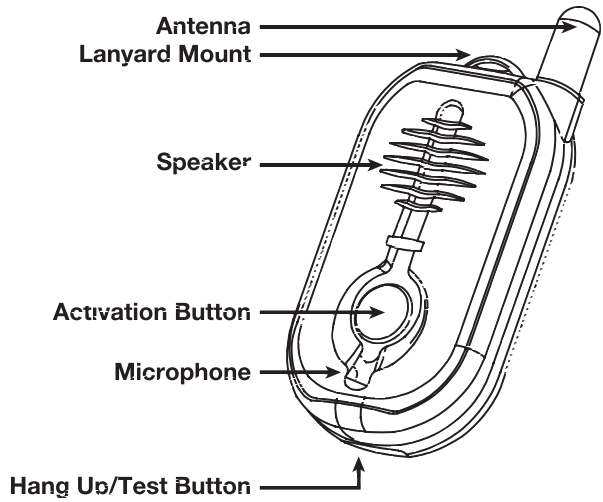

## Base Unit Features:

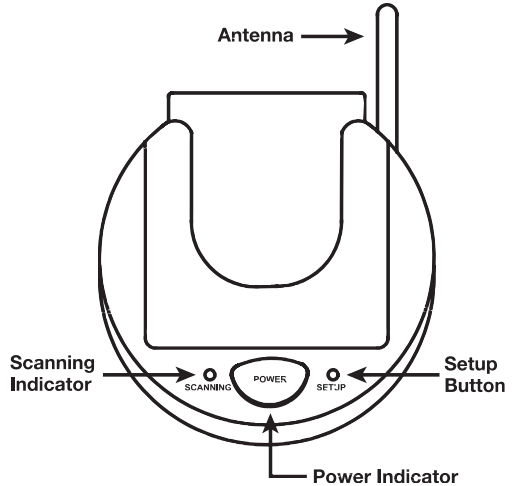



## Connecting The Guardian Alert 911:

### The Standard Connection:

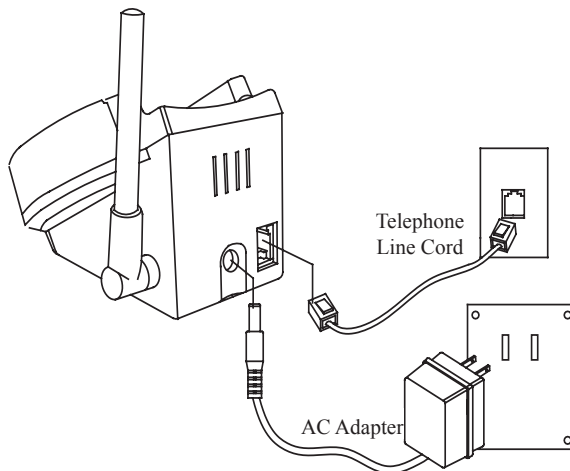

No special phone line or special service is required to use your Guardian Alert 911. Your phone will work with your existing touch-tone phone line and existing service. It works the same way as any cordless phone.

Simply plug in the AC ADAPTER and TELEPHONE LINE CORD as shown.

---

**Caution: Do not plug the AC ADAPTER into an outlet which is controlled by a switch. The switch could accidentally be turned off, thus rendering the BASE UNIT inoperable.**

---

### Connecting A Second Phone

You may need to plug a conventional telephone into same outlet used by the Guardian Alert 911. This is done very simply by using the telephone line splitter (included). See illustration on right.

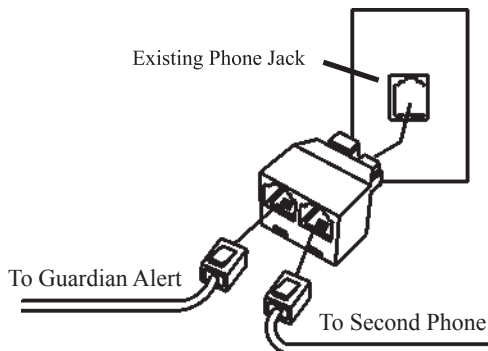



## If Your Phone System is VoIP.

Guardian Alert 911 will work well on most Voice Over IP systems. These systems send voice over the internet. You must however plug the Guardian Alert 911 into the special VoIP analog telephone adapter you use for your home phones. If you are not sure about this - consult your VoIP provider.

## If Your Home Has DSL

If your home has DSL service for your computer, you will need to use a DSL filter in line with the Guardian Alert 911 OR IT WILL NOT WORK. This filter can be obtained from a local electronics supplier or your DSL service provider. See illustration to the right.

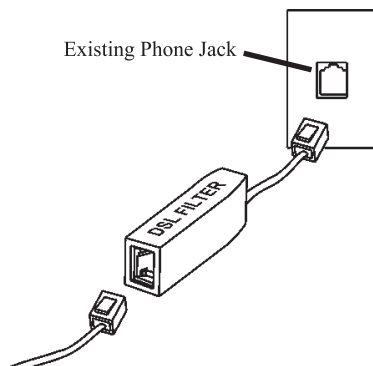





# Operating the Guardian Alert 911

## About The Pendant:

The PENDANT is a tiny, cordless speaker phone. It may be worn around the neck, on a belt using the supplied clip, or kept in your pocket.

There is a large blue button on the front of the PENDANT which activates the system and automatically dials the 911 emergency number when pressed for more than 1 second.

Once connected, you can speak directly with the 911 operator and explain the nature of your emergency.

## Attaching The Lanyard

If the neck strap is to be used, attach it as shown to the right.

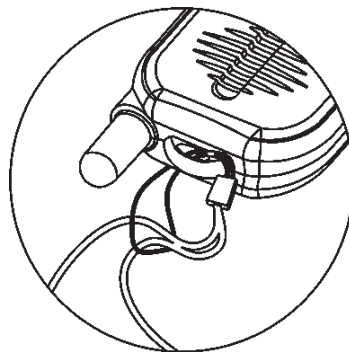

## Water Resistance

Please note that although the pendant is water resistant, it is not waterproof. Regular exposure to water, soaps, shampoos and conditioners can damage the water seals over time as well as affect the performance of the speaker – reducing the volume. To prolong the life of your pendant, we recommend laying the pendant just outside of the shower or bathtub – but well within reach should an accident happen in the shower or bathtub area.





## Battery Check

The Guardian Alert 911 has a built-in battery tester. When you press the button on the bottom of the PENDANT, a voice announcement will inform you of the battery condition. One of the following messages will be heard:

Test Button

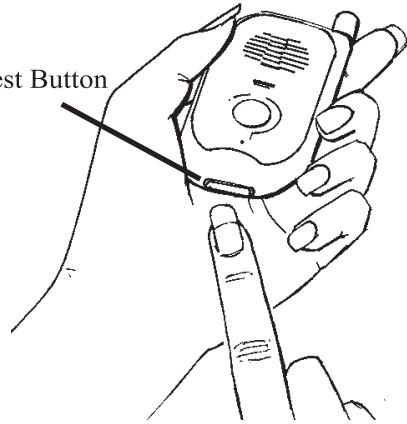

### “Battery is OK.”

Check the battery condition twice a month.

### “Replace battery soon.”

The battery should be replaced within the next week or two.

### “Replace battery now.”

The battery should be replaced by the next day.

Please note: If there is no response after pressing the button for one second or more, the battery is dead and must be replaced immediately.

---

***The battery should be tested twice a month along with the System Check outlined on the next page. If the battery is tested every day, it will be drained much more quickly and will not last as long.***

---



## System Check

The button on the bottom of the pendant case which is used to perform the BATTERY CHECK, will also perform a SYSTEM CHECK. Press and hold this button for more than four (4) seconds. One of the following announcements will be made.

Test Button

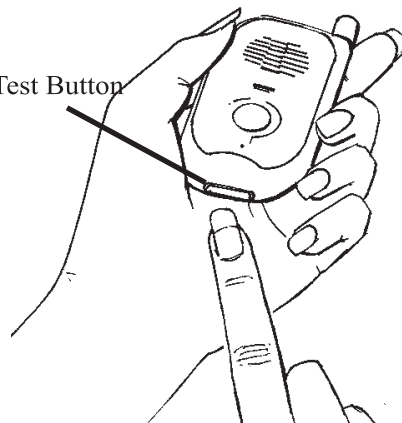

### “System check, all functions are OK.”

This confirms the following:

Battery status.

The PENDANT is working.

The BASE UNIT is working.

The BASE UNIT is connected to a working phone line.

The PENDANT is within range of the BASE UNIT.

### “System check failed.”

This confirms one or more of the following:

The PENDANT has malfunctioned.

The BASE UNIT has malfunctioned.

The PENDANT and BASE UNIT are not communicating with each other or are out of range.

The BASE UNIT is not connected to the phone line or can not get a dial tone for some reason.

If you receive a “System check failed.” notification, please refer to the TROUBLESHOOTING guide at the back of this manual to determine the cause.

**This feature is very useful - allowing you to confirm that the system has coverage from all parts of your home. Simply walk to the various parts of your home and push the Battery Check / System Check button until you hear the dial tone and the “SYSTEM CHECK, ALL FUNCTIONS ARE OK” voice prompt.**





**We highly recommend that you perform this System Check every month to confirm that your system is working properly and that the pendant and base station are in good communication and that the base station can get a dial tone. It is also recommended to perform this system check after a lightening storm that could damage the base station which is plugged into the phone line.**

## Emergency Dialing Using the Panic Button

In the event of an emergency, press the blue panic button on the front of the PENDANT. When this button is pressed for more than 1 second, the Guardian Alert 911 will automatically dial 911. When the emergency response operator answers, speak in a normal voice and you will be heard. There is no need to put the PENDANT up to your ear unless you are having trouble hearing. There is no need to hold the PENDANT up to your mouth. You will be clearly heard, even if the PENDANT is an arm's length away.

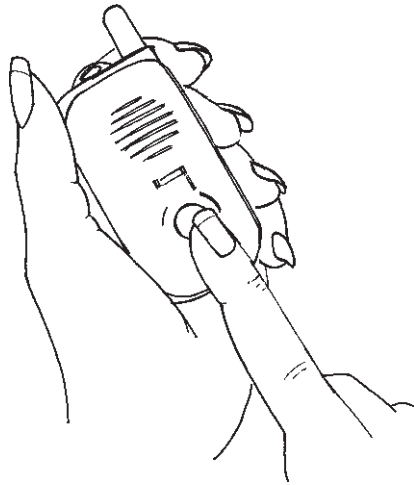



## Hanging Up

You can hang up any time by pressing the TEST BUTTON on the bottom of the pendant case. If the 911 operator does hang up the phone, and you do not hang-up with this test button, the system will still automatically turn off in 4 to 6 minutes

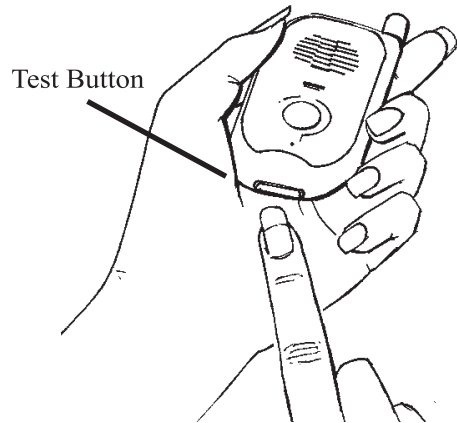

## Operating Range:

The operating range of your Guardian Alert 911 will depend on many factors including intervening walls, electrical interference or various appliances such as vacuum cleaners, microwave ovens, mixers, coffee grinders, hair dryers and other sources of electrical noise around the house. The system should cover your typical home (less than 3,500 sq ft) and a short distance into the front, side and back yards. Perform the System Check on page 11 to determine the boundaries of your system to know the limits of operation in your home and surroundings.



## TROUBLESHOOTING GUIDE

### What if I can't get the Guardian Alert 911 to work?

#### Step 1 – Check the PENDANT.

What to do:

Press the BATTERY CHECK/SYSTEM CHECK button on the bottom of the PENDANT.

What to expect:

A voice should announce the condition of the battery.

A light on the front of the PENDANT will come on.

If nothing happens, the most likely cause is that the battery is dead or has been installed backwards.

If the PENDANT says “Battery OK”, go on to step 2.

#### Step 2 – Check the connections on the BASE UNIT

What to do:

Make sure the AC ADAPTER is plugged into a live AC outlet and into the BASE UNIT.

What to expect:

The blue POWER light will be on if the BASE UNIT is connected to power.

If the POWER light is on and the BASE UNIT is connected to a working phone line, go on to step 3.



### **Step 3 – Make sure the PENDANT and the BASE UNIT are communicating with each other.**

Background information: The PENDANT and the BASE UNIT are connected by a wireless radio link. They must be synchronized to work together. They should have already been synchronized at the factory, but resetting this is simple.

What to do:

1. Press the “SET UP” button on the BASE UNIT until the red “SCANNING” light comes on. Release the SET UP button.
2. Now press and hold the PANIC BUTTON **and** the TEST BUTTON buttons (on the pendant) **at the same time** until the “SCANNING” light on the BASE UNIT turns off. It should turn off right after you push both buttons together.

What to expect:

The red light on the BASE UNIT will go out immediately after the 2 buttons are pressed at the same time. This indicates the PENDANT and the BASE UNIT are synchronized. At this point, everything should be working fine.

Now perform the System Check (pg 11) test again to make sure all is well.

**If your Guardian Alert 911 is still not working, call our TECH SUPPORT department at 703-934-7934.**

Information The FCC Wants You To Know:

FCC ID: TYD30911

This device complies with Part 15 of the FCC Rules. Operation is subject to the following two conditions: (1) this device may not cause harmful interference, and (2) this device must accept any interference received, including interference that may cause undesired operation.

Privacy of communications may not be ensured when using this phone.





## General Warnings And Precautions!

### Warning!

- LogicMark, LLC DOES NOT represent this unit to be completely waterproof. To reduce the risk of damage to the unit, DO NOT expose the pendant or base unit to prolonged water, rain or moisture.
- The Guardian Alert 911 is intended for residential use only. It may not work properly if connected to some commercial phone systems.
- The Guardian Alert 911 works with tone dialing systems only. Do not use if you have pulse dialing only.
- This product and/or accessories may contain lead, a chemical known to the State of California to cause birth defects or other reproductive harm.

Note: Gaurdian Alert 911 does not interfere with pacemakers.

### Important Safety Instructions:

**When using your Guardian Alert 911 , please observe the following instructions in order to reduce the risk of personal injury, electrical shock, or fire.**

1. Save these instructions for future reference.
2. Read all instructions carefully and make sure you understand them.
3. Unplug this product from the electrical outlet before attempting to clean it. Do not use any liquids for cleaning either the Base Unit or the Pendant. Use only a soft damp cloth.
4. Do not locate the Base Unit near any source of water, such as in the bathroom, near a sink in the kitchen, or the like.
5. Do not open the unit, (except the battery compartment as directed in these instructions) on the Pendant for any reason. Any attempt to open the case of the Base Unit or the Pendant will void the warranty and may damage the unit or prevent it from working properly.
6. Do not use any power source other than that supplied from LogicMark, LLC specifically for this product. Use of any other power source could damage your unit or make it unsafe.
7. If your unit becomes damaged do not attempt to repair it. Please return it to LogicMark, LLC for service or replacement as stipulated below under “ONE YEAR LIMITED WARRANTY”.







## LogicMark Disclaimer and Limited Warranty

**DISCLAIMER:** LogicMark, LLC. will not be responsible for the improper use of the Guardian Alert 911, nor will it be responsible for failure resulting from the use of other equipment connected to the same phone line. We will not be responsible for the quality of the phone line or the reliability or quality of the phone service with which the Guardian Alert 911 is used. LogicMark, LLC. will not be responsible for the installation of the Guardian Alert 911. It will not be responsible for the improper use or abuse of this unit.

**COMMUNICATION AND RESPONSE LIMITATIONS:** Purchaser acknowledges that signals which are transmitted over telephone lines, or other modes of communication pass through communication networks wholly beyond the control of LogicMark LLC and are not maintained by LogicMark LLC, and, therefore, LogicMark LLC shall not be responsible for any equipment or communication failure which prevents transmission signals from reaching police emergency 911 operators or damages arising therefrom. Purchaser acknowledges that LogicMark LLC provides no response to its Guardian Alert 911 equipment. The equipment is designed to communicate with police emergency 911 operators and LogicMark LLC is not and shall not be responsible for police or other emergency response time or that any response will be provided by the police emergency 911 response center.

**ELECTRIC AND TELEPHONE SERVICE IS NECESSARY AND PURCHASER'S RESPONSIBILITY:** Purchaser acknowledges that the Guardian Alert 911 equipment (including optional Battery Back-up accessory) plugs into a standard telephone jack and communicates over standard telephone lines using two way voice communication. You must use a special adaptor (not supplied) for the equipment to work with VOIP Internet transmission. VOIP Internet will not work when your electricity service is interrupted unless you have battery back up for your computer and Guardian Alert 911 system. Purchaser acknowledges that the Guardian Alert 911 equipment (and the optional Battery Back-up accessory) requires 110 Volt AC power and electrical outlets and receptacles, telephone hook-ups, RJ11 Block or equivalent, all of which is Purchaser's responsibility to obtain and





**TESTING AND SERVICE OF Guardian Alert 911 EQUIPMENT:** The Guardian Alert 911 equipment (and optional Battery Back-up accessory), once installed, are in the exclusive possession and control of the Purchaser, and it is Purchaser's sole responsibility to test the operation of equipment and request warranty service if the equipment is under warranty.

**LIMITED WARRANTIES OR REPRESENTATIONS.** LogicMark LLC does not represent nor warrant that the Guardian Alert 911 system will prevent any loss, damage or injury to person or property, or that the personal emergency alert system will in all cases provide the protection for which it is installed or intended. Purchaser acknowledges that LogicMark LLC is not an insurer, and that Purchaser assumes all risk for loss or injury to Purchaser's property or person. LogicMark LLC has made no representation or warranties, except those expressed herein and hereby disclaims any warranty of merchantability or fitness for any particular use.

**PURCHASER'S EXCLUSIVE REMEDY:** Purchaser's exclusive remedy for LogicMark LLC's default hereunder is to require LogicMark LLC to repair or replace, at LogicMark LLC's option, any equipment or part of the personal emergency alert system which is non-operational during LogicMark LLC's warranty period.

**LIMITATION OF LIABILITY:** The Guardian Alert 911 equipment is not designed or guaranteed to prevent any loss or injury. This Limited Warranty and Disclaimer of Liability constitutes the terms of sale and use of the Guardian Alert 911 (and accessory) equipment, and if, notwithstanding these terms of sale and use of the product, there should arise any liability on the part of LogicMark LLC as a result of any cause whatsoever, regardless of whether or not such loss, damage, or personal injury was caused by or contributed to by LogicMark LLC's negligence to any degree or failure to perform any obligation or strict products liability, such liability will be limited to an amount paid by the Purchaser to LogicMark LLC for the product, or to the sum of \$150.00, whichever is greater.





## **ONE YEAR LIMITED WARRANTY**

LogicMark, LLC warrants to the original consumer/purchaser that this product shall be free of defects in material and workmanship under normal use and circumstances for a period of **one** (1) year from the date of original purchase for use. When the original consumer/purchaser returns the product pre-paid to LogicMark, LLC; 10106 Bluegrass Pkwy; Louisville KY, 40299, USA within the warranty period, and if the product is defective, LogicMark, LLC will at its option repair or replace such.

This warranty shall constitute the sole liability of LogicMark, LLC concerning the product. LogicMark, LLC expressly disclaims all other warranties INCLUDING, WITHOUT LIMITATION, THE WARRANTIES OF MERCHANT ABILITY AND FITNESS FOR A PARTICULAR PURPOSE. NO PERSON, FIRM, OR CORPORATION IS AUTHORIZED TO ASSUME FOR LogicMark, LLC. ANY OTHER LIABILITY IN CONNECTION WITH THE SALE AND USE OF THE PRODUCT. LogicMark, LLC and agents and distributors will bear no liability whatsoever for incidental or consequential damages or charges of any kind.

Some states do not allow the exclusion or limitation of incidental or consequential damages, so the above disclaimer regarding incidental or consequential damages may not apply to you.

This warranty is void if the product has been damaged or tampered with or if the product or any such parts have been opened. In all cases of damage during shipment, a claim must be filed with the shipping carrier and not with LogicMark, LLC.

This warranty gives you specific legal rights; you may also have other rights which vary from state to state.

## **OUT OF WARRANTY REPAIRS**

If the warranty period has expired or if you are not the original owner of the product, LogicMark, LLC will at its option either (1) replace this product with a functionally similar (but not necessarily identical) refurbished product or (2) repair the original product and return it to the original consumer/purchaser after payment of repair/replacement charges has been received.





# LogicMark

10106 Bluegrass Pkwy;  
Louisville KY, 40299

Tel: 1-703-934-7934

Toll Free: 1-800-519-2419

Fax: 1-703-934-7935

**[www.LogicMark.com](http://www.LogicMark.com)**

©2012 LogicMark, LLC