

Easel Plus

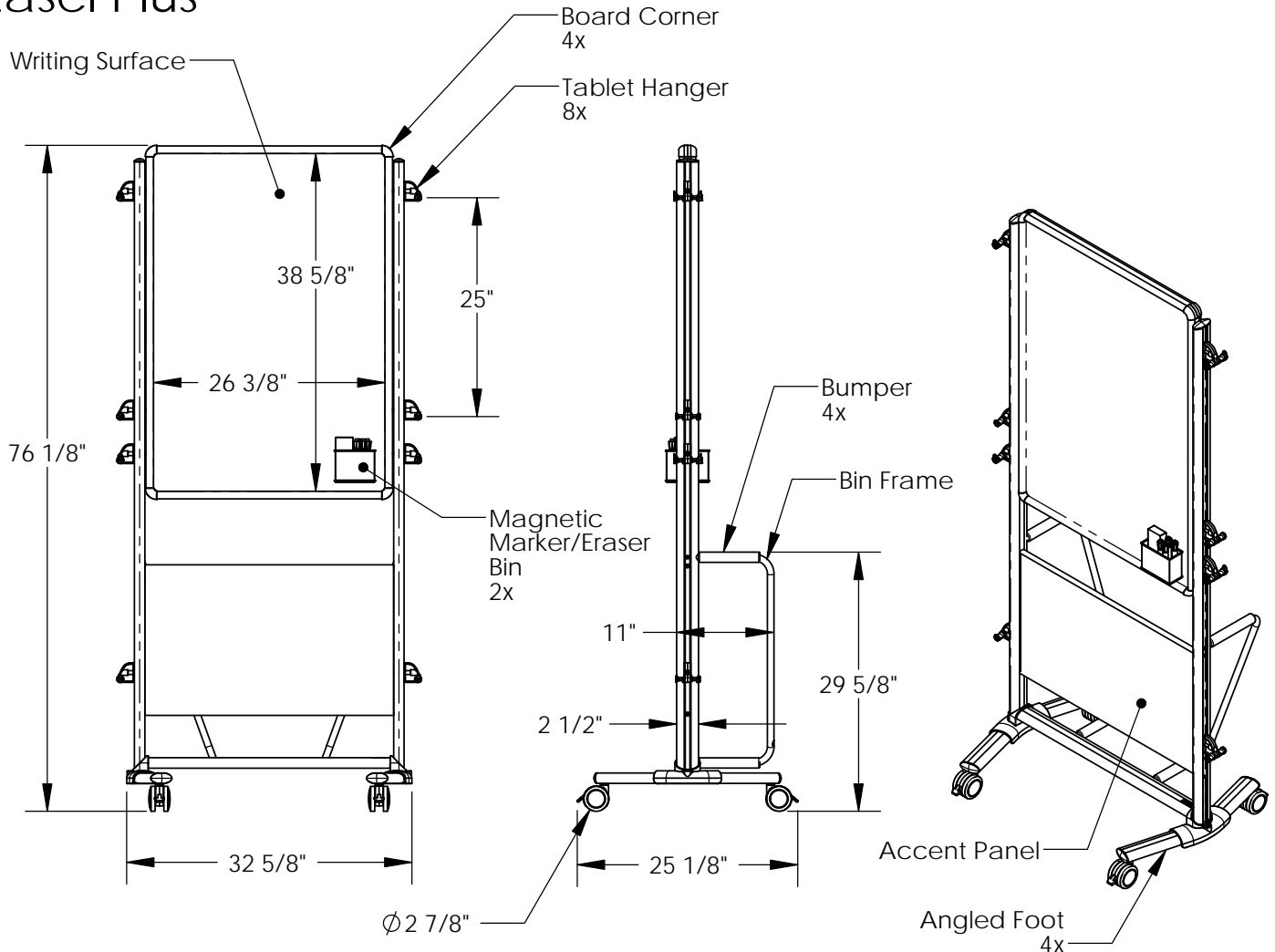

Materials:

- Framing: Satin anodized aluminum extrusion
- Foot Castings: Powder coated die cast aluminum
- Writing Surfaces: White porcelain coated 28 gage steel sheet
- Board Corners, Rail Caps, Tablet Hangers, and Hanger Pegs: Gray thermoplastic
- Swivel Casters with Wheel Locks: Thermoplastic elastomer
- Bumpers: Black NPVC foam
- Magnetic Marker/Eraser Bins: Silver painted steel mesh weldment
- Accent Panels: Plastic

Features:

- Writing surface on front and back.
- Has angled feet for grouping with other Nexus easels and/or IdeaWalls
- Includes 2 magnetic marker/eraser bins, 1 eraser, and 4 assorted color dry erase markers.
- Designed to store and display 8 Nexus Tablets - hung from the side posts.
- The accent panels are available in 4 colors - Carbon, Emerald, Sand, and Pacific
- Guaranteed for 10 years

Notes:

- Some assembly required
- Related Products: Nexus X-Pegs, Nexus Caddy, Nexus Tablet, Nexus Easel and Nexus IdeaWall