

**Bilbao Series
BBS213**

Features

Geometric banded wall mount sconce is ADA compliant and provides low brightness control. Open top and bottom for wall wash effect. Fixture mounts to standard junction box (not included).

Construction

Back plate is die-formed of 22-gauge steel. Frame consists of .06" aluminum extruded bands that are screwed to vertical supports. Standard mounting holes and hardware are included. Power supply connections must be made inside a junction box (not included).

Finish

Back plate is finished in lighting grade white baked gloss enamel paint. Frame assembly consists of extruded satin aluminum bands with clear lacquer topcoat.

Diffuser

Diffuser is .100" thick frosted white slump glass.

Electrical

This unit can be ordered in the following options: with UL listed instant-start, electronic normal power factor ballast; 120V 60Hz AC (EC suffix), 120-277 Universal 50/60Hz AC (MV suffix).

Lamping

For use with 2/13 or 2/26 watt compact fluorescent 4 pin quad lamps; supplied by others.

Certification

All fixtures are cULus listed for damp locations.

Options

120-277V HPF
Dimming
ENERGY STAR qualified when ordered with 120V ballast and lamp

For photometric information, consult factory.

Specifications and dimensions
subject to change without notice.

Ordering Information:

Model No.	Lamps		Dimensions				
	120V	120-277V	Qty	Lamp	H	W	D
Satin Aluminum	BBS213SAEC	BBS213SAMV	2	13W CFQ 4 PIN	11-1/8"	10"	4"

Project		Fixture Type
Location		Quantity
Approved By	Date	Catalog Number

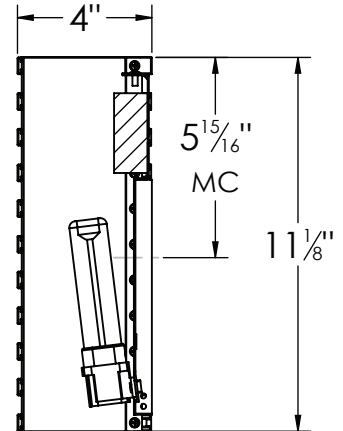
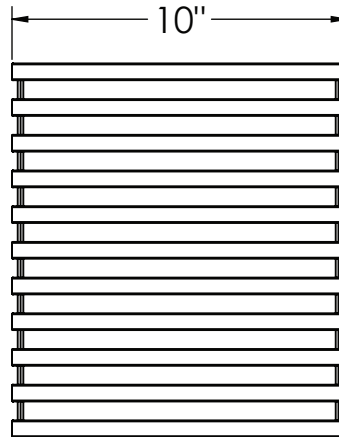

MC - Mounting Center