

# PBENDSS

## Space Saver Parts Bender



**STOP!** CONTACT CUSTOMER SERVICE WITH QUESTIONS OR PROBLEMS.

DO NOT RETURN THIS PRODUCT TO THE RETAILER.

If you experience a problem or need parts for this product, visit our website <http://www.buffalotools.com> or call our customer help line at **1-888-287-6981, Monday-Friday, 8 AM - 4 PM Central Time**. A copy of the sales receipt is required.

KEEP THIS INFORMATION, SALES RECEIPT & APPLICABLE WARRANTY FOR FUTURE REFERENCE. READ ALL INSTRUCTIONS AND WARNINGS BEFORE USING THIS PRODUCT. When unpacking, check to make sure all parts listed are included. If any parts are missing or broken, please call Customer Service at 1-888-287-6981.

FOR CONSUMER USE ONLY - NOT FOR PROFESSIONAL USE

# PARTS LIST

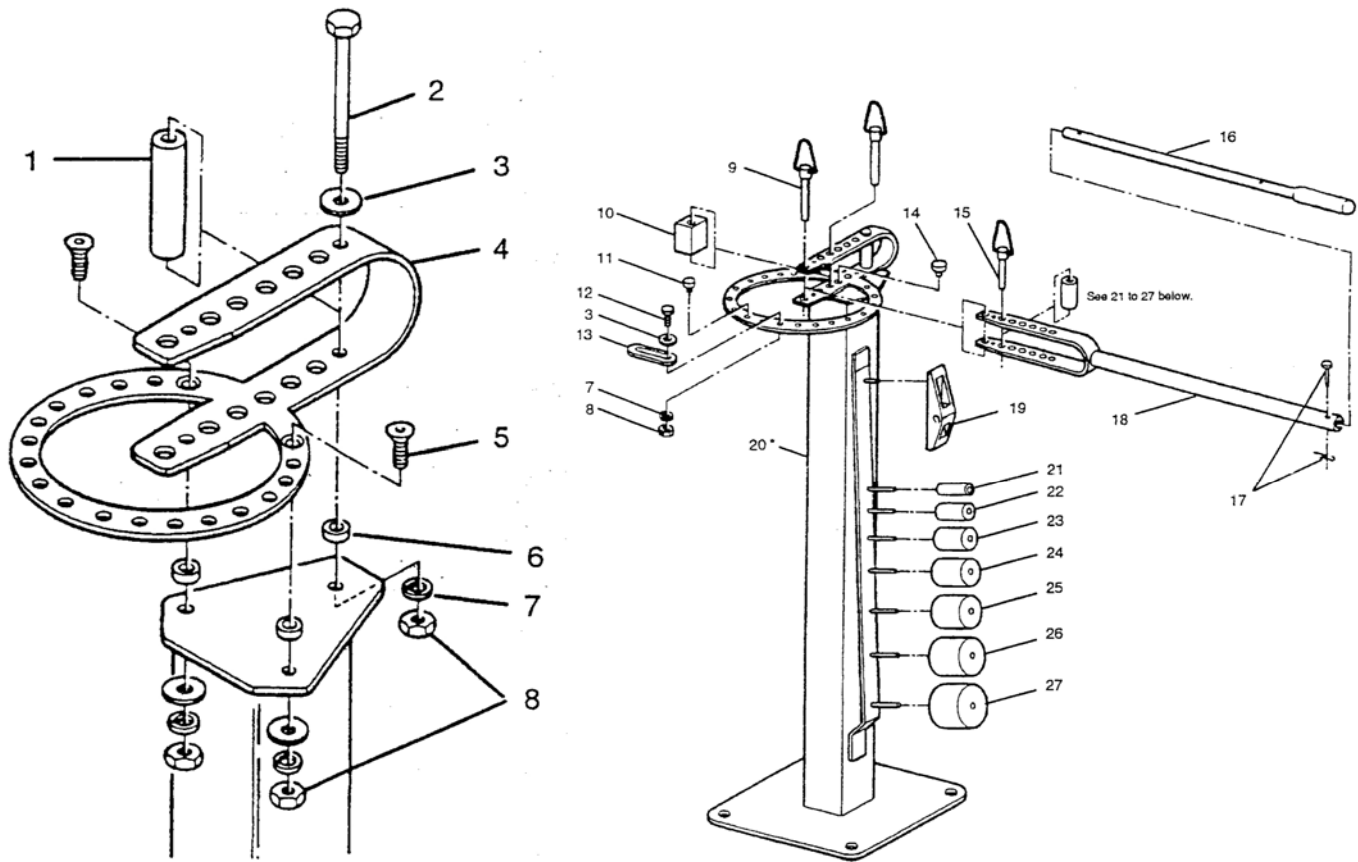

#	Description	Part #	#	Description	Part #
1	Spacer, Loop	BT20001	5	Bolt, Flat Head 3/8 Inch	BT20005
2	Bolt 3/8 In x 4 1/8 In	BT20002	6	Spacer Ring	BT20006
3	Washer, Flat 3/8 In	BT20003	7	Washer Lock 3/8 Inch	BT20007
4	Ring Assembly	BT20004	8	Nut	BT20008
9	Hitch Pin, Long	BT20009	19	Attachment Sharp-Angle-Bend	BT200019
10	Stop Block	BT200010	20	Stand	BT200020
11	Support Block	BT200011	21	Die 1 Inch	BT200021
12	Bolt. 3/8 inch x 1 1/8 in	BT200012	22	Die 1 1/4 Inch	BT200022
13	Stop, Adjustable	BT200013	23	Die 1 1/2 Inch	BT200023
14	Stop, Fixed	BT200014	24	Die 1 3/4 Inch	BT200024
15	Hitch Pin, Short	BT200015	25	Die 2 Inch	BT200025
16	Arm Handle Extension	BT200016	26	Die 2 1/2 Inch	BT200026
17	Pin Handle With Hairclip	BT200017	27	Die 3 Inch	BT200027
18	Handle	BT200018			

# Assembly

1. To attach the ring assembly to the stand (refer to the illustration below):
  - a. Attach the loop end of the ring assembly to the stand. Use the long bolt, flat washer, thick spacer (inside the loop), thin spacer, lock washer, and lock nut.
  - b. Attach the ring end to the stand with the two flat-head bolts, using thin spacers, flat washer, lock washers, and lock nuts.
2. Insert the loop end of the handle inside the loop of the ring assembly, and secure it by inserting one of the two longer hitch pins.
3. Remove the hairclip from the handle pin, then remove the pin from the handle. Pull out the extension arm, install the pin in the outer hole, and reinstall the hairclip.
4. Set the Bender in the position where you intend it to be used. Rotate the handle as far as it will go in both directions, to be sure there will be no obstructions when bending.
5. Attach the Bender's base securely to the floor.

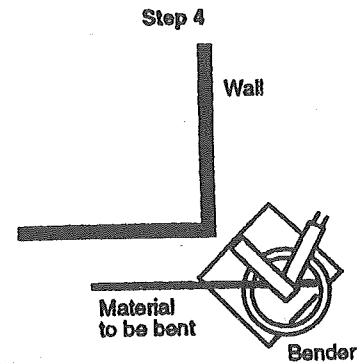
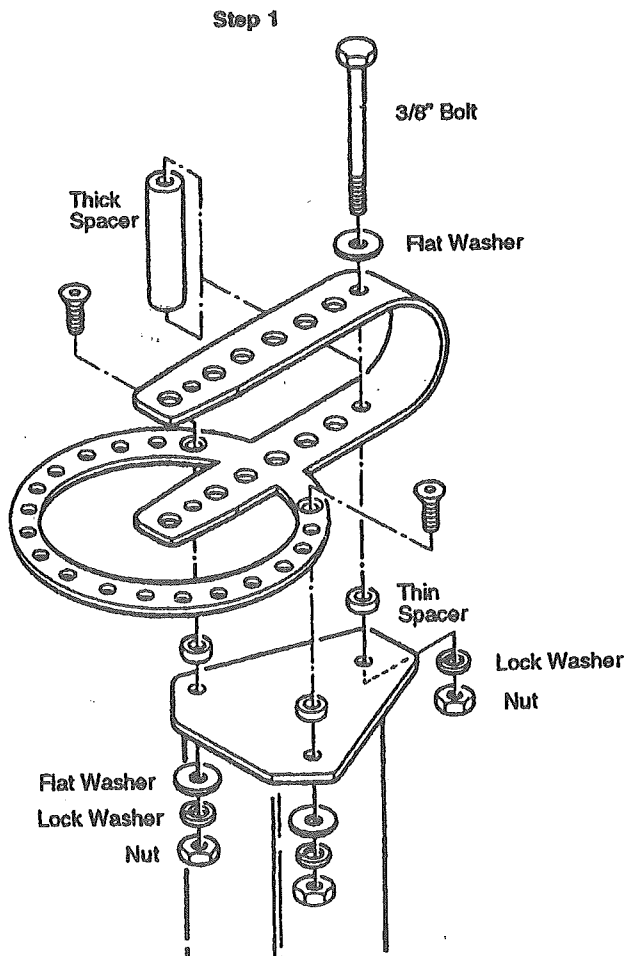
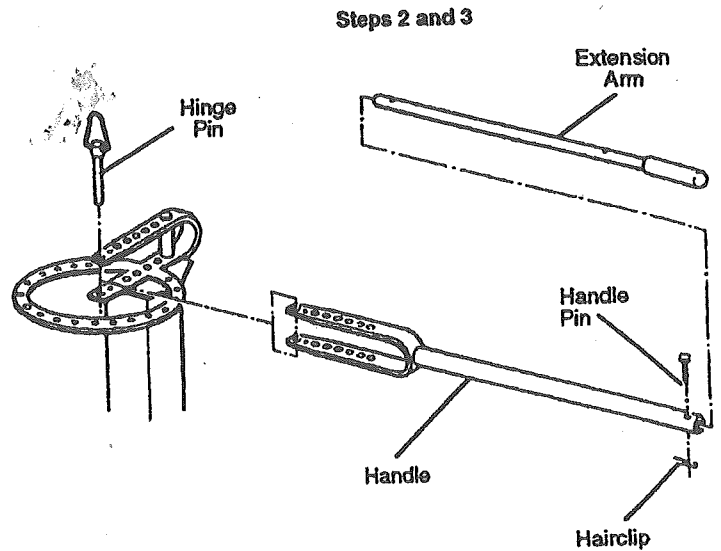

**! WARNING**

To avoid serious injury, do not operate the Bender unless it is securely attached to the floor or workbench.

# Operation: General Information

## Basic Operation

Most of this manual is devoted to showing you how to make some common parts at a typical size. Other than those specific instructions, setting up the Bender to form your particular parts will involve a certain amount of trial-and-error.

You will notice some differences in operation depending on whether you are forming the piece around a die, or whether you are making a sharp-angle bend in the piece. However, in general you will:

1. Determine the appropriate material and size for the part(s) to be made.
2. Determine the appropriate dies to install on the center pin and/or the pin installed in the handle. Determine the appropriate hole for attaching the handle to the ring assembly's loop.
3. Install the stop block or the sharp-angle-bend attachment, as appropriate. Install the block support. If the stop block is used, orient it properly. Refer to pages 4 and 5 for more information on the stop block and the sharp-angle-bend attachment.
4. Insert the blank stock into the Bender, and position it properly for the first bend.
5. Make the first bend. Recheck the angle and location before continuing.
6. Make any additional bends in the same way. In some cases, you may have to remove the piece from the Bender and turn it end-for-end or upside-down.

## Hole Identification

In the examples shown in this manual, the holes in the loop and those in the handle are identified by a number. Refer to the illustration at right.

## Measuring Bend Angles

When accuracy is required, you will need a suitable device for measuring the bend angles.

## Fixed and Adjustable Stops

If you are making multiple parts with the same bend angle, using the same setup (dies and hole locations), the operation will be speeded up by installing either the fixed or adjustable stop in the appropriate hole in the ring assembly.

After determining the handle rotation, insert the fixed stop into the next open hole and use as a guide for bending additional parts.

When greater precision is required, attach the adjustable stop as accurately as you can at the limit of handle rotation. Make a test part with scrap material, and reposition the adjustable stop as necessary. Tighten bolt and nut securely before bending production parts.

## Notes

- ◆ If precise dimension are required, start by making a test part using scrap material of the same thickness. Readjust the setup as necessary.
- ◆ Once you determine the dimensions, die size(s), holes, and bending sequence for a part, write down the information for future reference.

Hole Identification

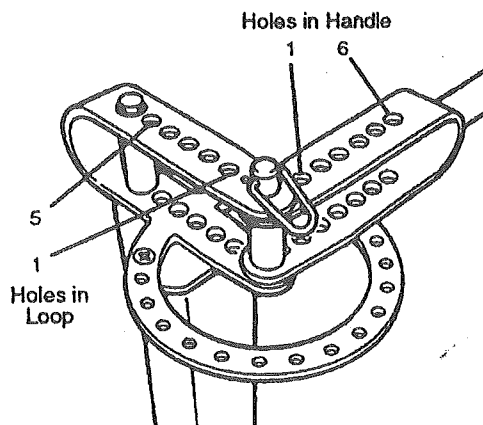

Fixed and Adjustable Stops

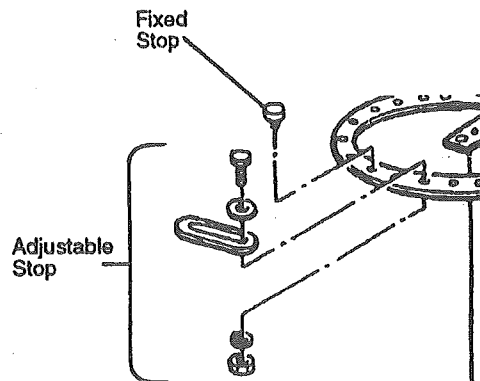

# Operation: Using the Stop Block

**IMPORTANT:** Read page 3 before you proceed to this section.

## Purpose of the Stop Block

The stop block prevents the material from rotating while a forming die in the handle bends the material around either the center pin or another die that has been installed on the center pin.

When you are bending material, the stop block will be located (using a hitch pin) at one of the five large holes in the middle of the ring assembly's loop. (The large hole at the open-end of the loop is for the center pin.) You will have to determine by trial which hole you will use, depending on the thickness of the material being bent, the size of the center-pin die, and the orientation of the stop block.

## Positioning the Stop Block

The stop block can be placed in several orientations by rotating it on the hinge pin or by turning it upside down and rotating it on the pin. However, only four of the possible orientations are used when bending. Throughout this manual, those four orientations are identified by a number (refer to the illustration at right).

**CAUTION:** Always position the stop block **off-center to the right**—no matter which face is used against the material. If positioned off-center to the left, the block will turn and the material will slip in the Bender.

To position the stop block (that is, to select the proper orientation and the proper hole in the loop):

1. Connect the handle to the center pin of the loop, with the appropriate die installed on the center pin.
2. Install the appropriate die at the appropriate hole in the handle.
3. Inset a piece of the material to be formed. With the handle all the way back (counterclockwise), install the stop block—in the orientation that places it as close to the center pin as possible.

**IMPORTANT:** Always use the loop hole that places the stop block as close to the center pin or die as possible, while leaving space for the material to be inserted.

If there is too much space between the stop block and the center pin or die, turn the block to a different orientation or move the block one hole closer to the center.

## Positioning the Block Support

The block support must be located under the stop block as shown, to keep the block centered vertically in the loop.

Install the support in the appropriate loop hole where it will support the stop block but not interfere with inserting the hitch pin all the way through the block hole and the lower hole in the loop.

## Clamping

If the stop block is positioned correctly, the material will normally not have to be clamped in the Bender. However, when you are making special bends or need precise dimensions, it is helpful to clamp the material against the stop block using a vise-grip pliers as shown at right.

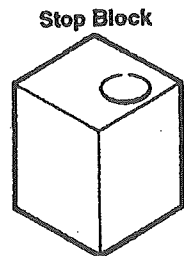

Stop Block Orientations

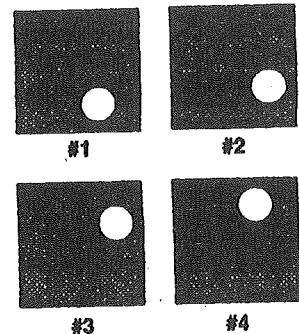

Positioning the Block Support

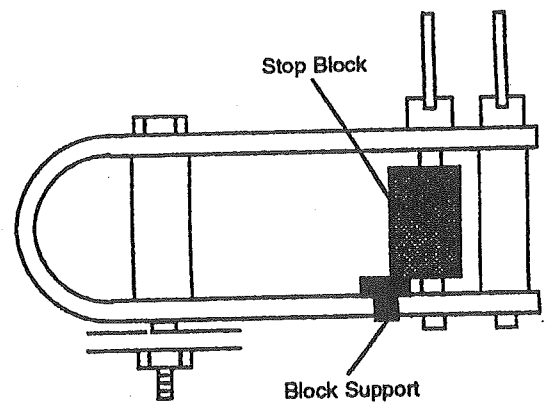

Clamping the Material

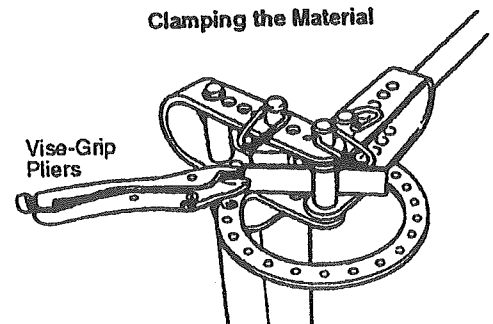

# Operation: Using the Sharp-Angle-Bend Attachment

**IMPORTANT:** Read page 4 before you proceed to this section.

## Purpose of the Attachment

The sharp-angle-bend attachment is used instead of the stop block (page 6) when you make a right-angle bend or other sharp bend in flat material.

## Positioning the attachment

In contrast to the stop block, the sharp-angle bend attachment has only one correct orientation—as shown at right, and with the hinge pin in the #2 hole in the loop.

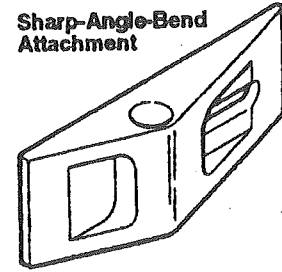

## Positioning the Block Support

The block support must be located under the sharp-angle-bend attachments, to keep the attachment centered vertically in the loop. (Compare the illustration on page 4, with the stop block.)

Install the support in the #3 loop hole, so it will support the attachment but not interfere with inserting the hitch pin all the way through the attachment's hole and the lower hole in the loop.

## Clamping

The material should not need to be clamped when using the sharp-angle-bend attachment.

## Bending the Material

Make thin chalk marks on the flat material to show where you want to make the bends. For an example, see page 7.

Insert the material into the Bender so that half the width of the chalk mark shows and the other half is covered by the bending edge of the attachment.

If you are making **two right-angle bends** on the same side of the material, space their chalk marks about  $\frac{1}{8}$ -in. farther apart than the desired inside dimension after the bend.

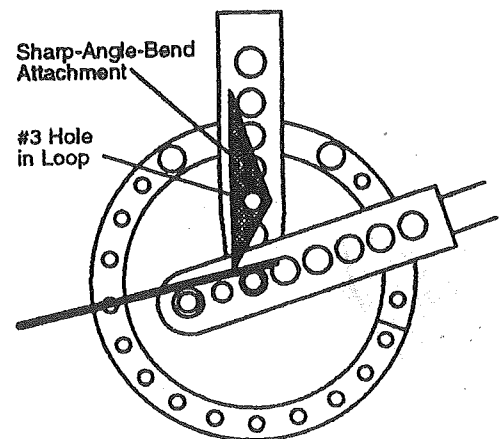

# Example: Bending Handles

## Handles from Round Stock

To make a typical handle, using a 9-in. length of  $\frac{3}{8}$ -in. round stock and two pieces of flat stock:

**NOTE:** To make other sizes of handles, experiment to find the appropriate die sizes and stop block orientation.

1. With a long hinge pin, attach the handle and ring loops at their center-pin holes. Install a 1-in. die on the center pin.

With the short hinge pin, install a 2-in. die in the handle (#2 hole).

2. With a long hinge pin, install the stop block (oriented as in A).

3. Insert the round stock into the Bender so that it extends 2-in. beyond the center-pin die (see B), and make the first bend to 90°.

4. Turn the part end-for-end, position it as in C, and make the second 90° bend. Remove the stock from the Bender.

5. Drill  $\frac{5}{8}$ -in. holes in the flat stock, and insert the handle halfway through the holes.

**NOTE:** Always drill the holes the same size as the diameter of the handle stock.

6. Weld the flat stock pieces in place from the back side. If any weld material extends below the surface of the flat plate, grind it flush.

TYPICAL HANDLES FROM ROUND STOCK

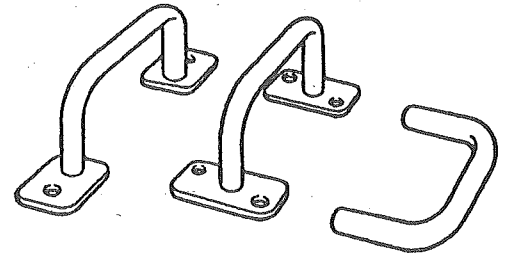

STOCK REQUIRED (for this example)  
One 9-in. length of  $\frac{3}{8}$ -in. round stock  
Two pieces of flat stock, of desired size

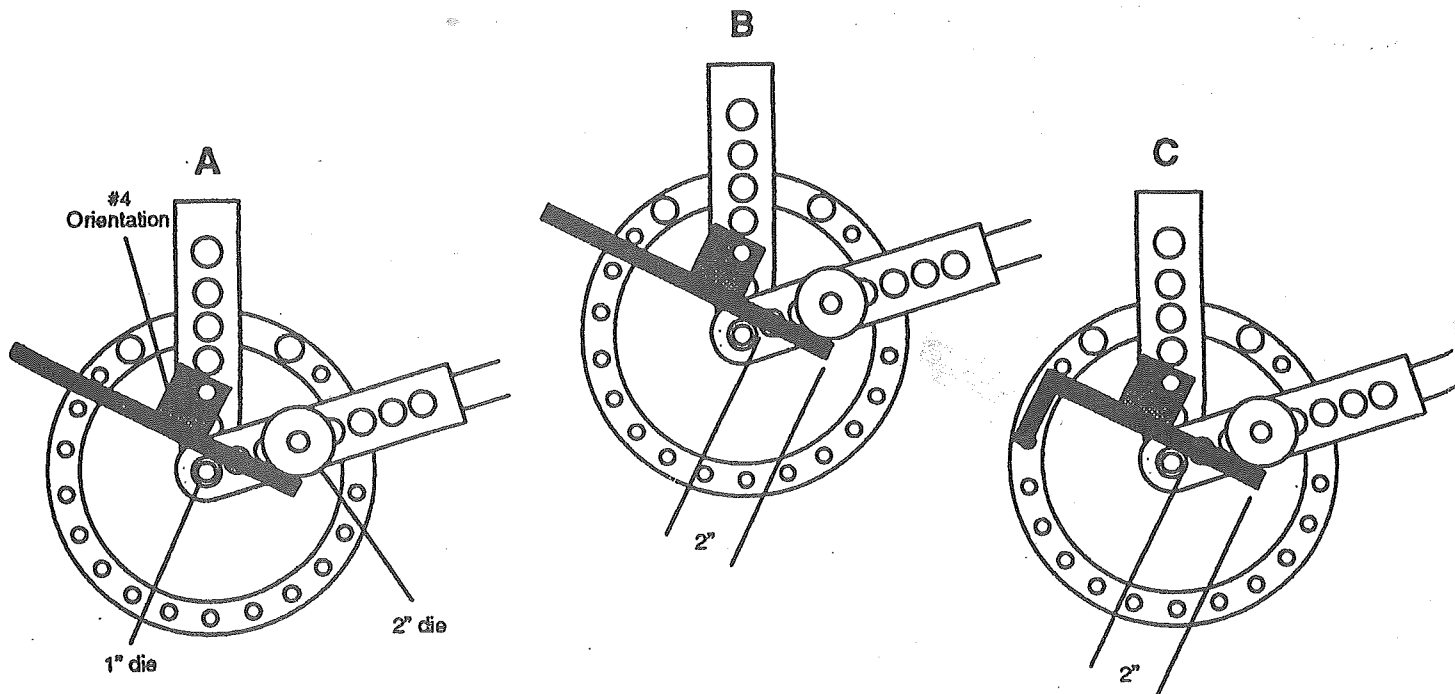

## Example: Bending Handles (continued)

### Handles from Flat Stock

To make a typical handle, using a 9-in. length of  $\frac{3}{16}$ -in x 1-in. hot-rolled flat stock:

**NOTE:** To make other sizes of handles, experiment to find the appropriate bend locations.

1. Install the sharp-angle-bend attachment.
2. Place chalk marks on the material as shown under "Bend Sequence." the #1 and #2 marks are on one face of the material, and the #3 and #4 marks are on the opposite face.
3. Insert the flat stock into the Bender to the #1 mark (as in A) and make a 90° bend. Check the angle before continuing.
4. Set the adjustable stop so each bend will be 90°.
5. Turn the stock end-for-end. Insert it to the #2 mark (as in B), and make a 90° bend.
6. Turn the stock over front-to-back. Insert it to the #3 mark (as in C), and make a 90° bend.
7. Turn the stock end-for-end. Insert it to the #4 mark (as in D), and make a 90° bend.
8. Grind and sand all sharp corners.

TYPICAL HANDLE FROM FLAT STOCK

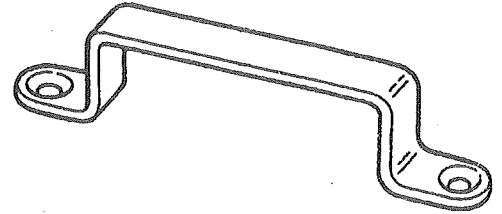

STOCK REQUIRED (for this example)  
One 9-in. length of  $\frac{3}{16}$ -in x 1-in. hot-rolled flat stock

BEND SEQUENCE

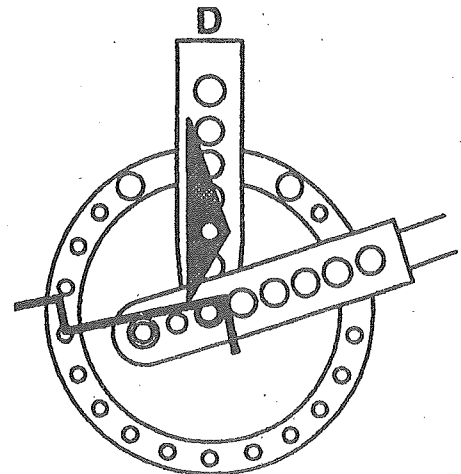
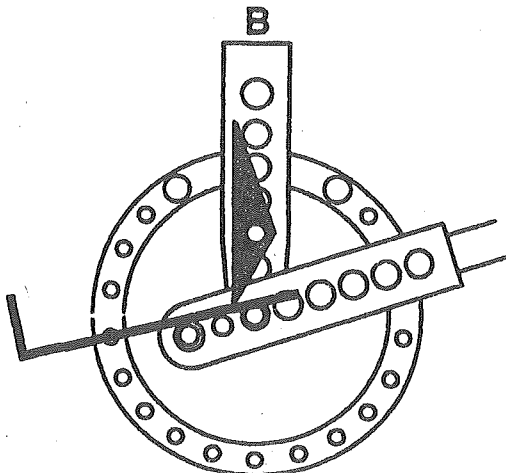
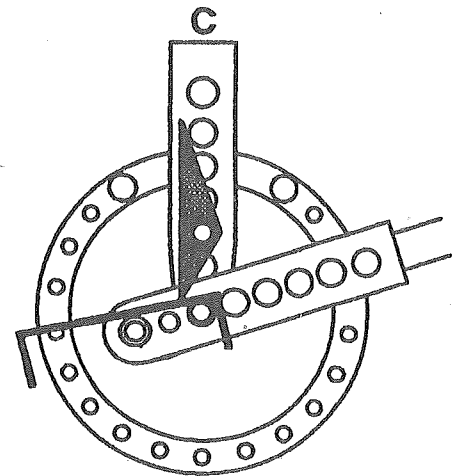
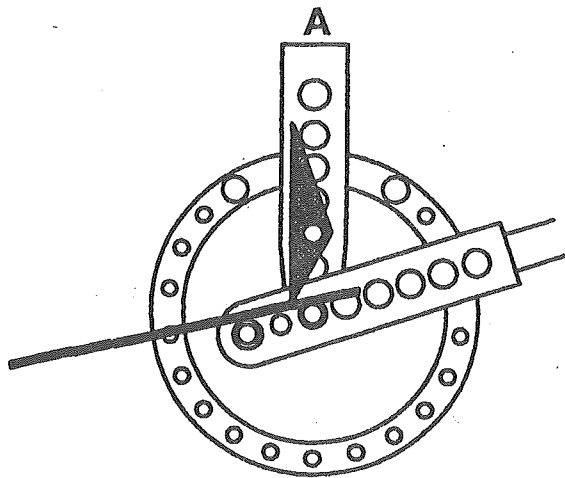



# Example: Bending Tube Clamps

## Single-Tube Clamp

To make a 1-in. I.D. tube clamp (for clamping 1-in. O.D. tubing), using a 4½-in length of ⅜-in. x 1-in. hot-rolled flat stock:

**NOTE:** To make other sizes of clamps, experiment to find the appropriate die sizes and stop block orientation.

1. With a long hinge pin, attach the handle and ring loops at their center-pin holes. Install a 1-in. die on the center pin.

With the short hinge pin, install a 1½-in. die in the handle (#2 hole).

2. With a long hinge pin, install the stop block (oriented as in A).

3. Insert the flat stock into the Bender so that it extends 1½-in. beyond the center-pin die (as in B).

Clamp the stock against the stop block using a vice-grip pliers, to prevent the stock from slipping.

4. Make the first bend by pulling the handle around until the handle die runs off the end of the piece.

5. Remove the stop block and the two dies. Change the handle connection, and install the sharp-angle-bend attachment (as in C).

6. Insert the stop pin into the 6th hole of the ring (counting clockwise from the closed end of the loop).

7. Make the second bend by pulling the handle until it is about ⅛ in. from the stop pin.

TYPICAL TUBE CLAMPS

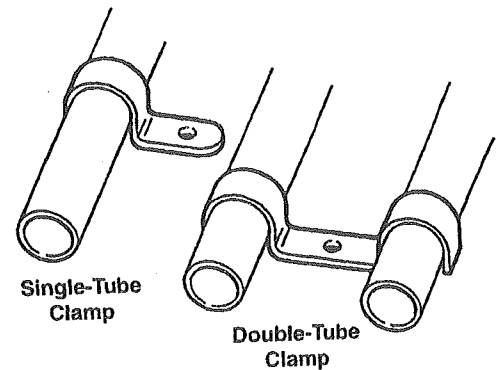

STOCK REQUIRED (for this example)

One 4½-in. length of ⅜-in x 1-in. hot-rolled flat stock

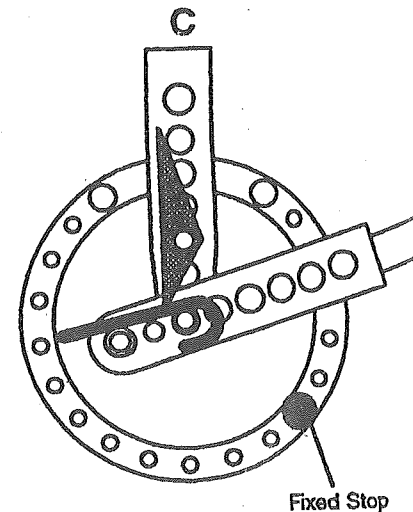
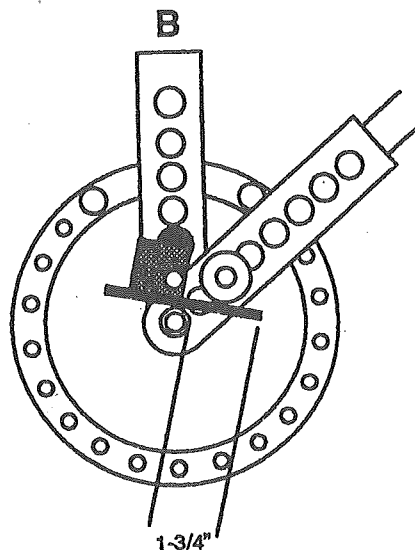
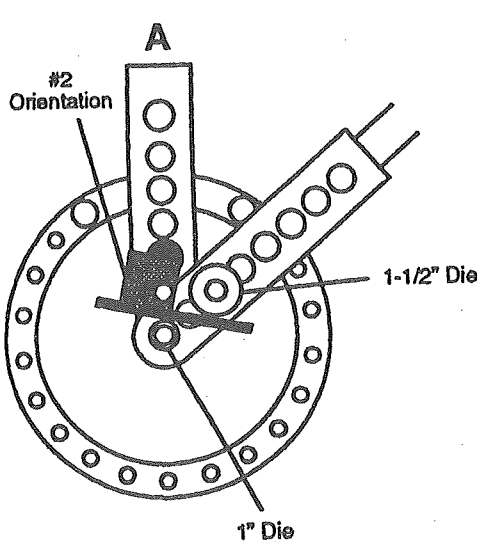

## Example: Bending Tube Clamps (continued)

STOCK REQUIRED (for this example)

One 6½-in. length of ⅜-in x 1-in. hot-rolled flat stock

### Double-Tube Clamp

To make a 1-in. I.D. tube clamp (for clamping two lengths of 1-in. O.D. tubing), using a 4½-in length of ⅜-in. x 1-in. hot-rolled flat stock:

**NOTE:** To make other sizes of clamps, experiment to find the appropriate die sizes and stop block orientation.

1. With a long hinge pin, attach the handle and ring loops at their center-pin holes. Install a 1-in. die on the center pin.

With the short hinge pin, install a 1½-in. die in the handle (#2 hole).

2. With a long hinge pin, install the stop block (oriented as in A).
3. Insert the flat stock into the Bender so that it extends 1¾-in. beyond the center-pin die (as in B).
4. Make the first bend by pulling the handle around until the handle die runs off the end of the piece.
5. Reverse the part end-for-end. Insert it into the Bender so that it extends 1¾-in. beyond the center-pin die (as in C).
6. Make the second bend by pulling the handle around until the handle die runs off the end of the piece.
7. Remove the stop block, and install the sharp-angle-bend attachment.
8. You will have to temporarily remove the center pin to insert the piece into the Bender. Slide the piece as far left as possible, against the center pin (as in D).
9. Make the third bend by pulling the handle until it is about ⅛-in. from the stop pin.
10. Reverse the part end-for-end. Slide the piece as far left as possible, against the center pin (as in E). You will again have to temporarily remove the center pin to insert the piece into the Bender.
11. Make the fourth bend by pulling the handle until it is about ⅛ in. from the fixed stop.

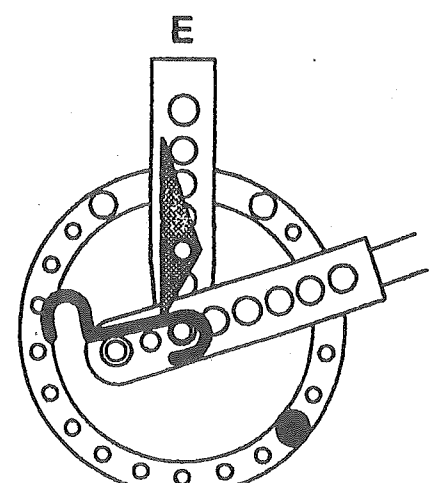
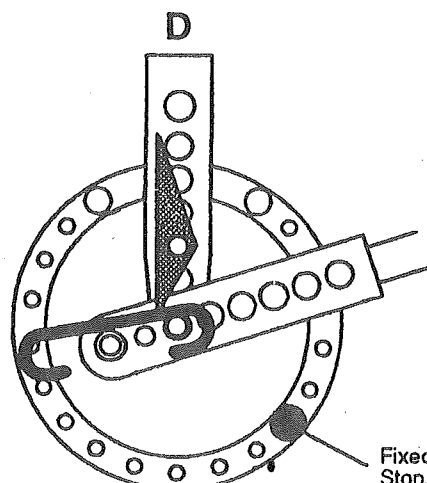
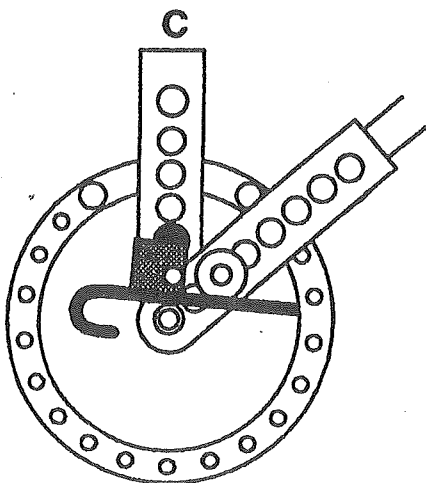
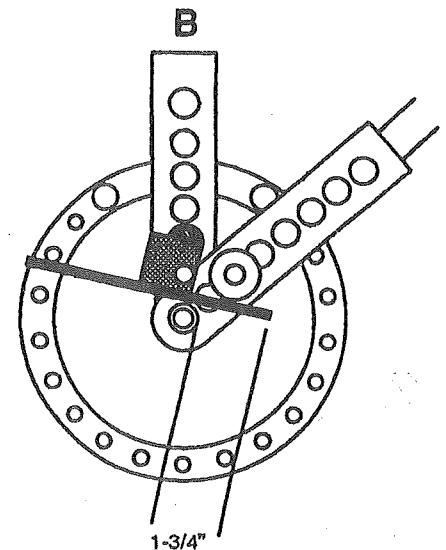
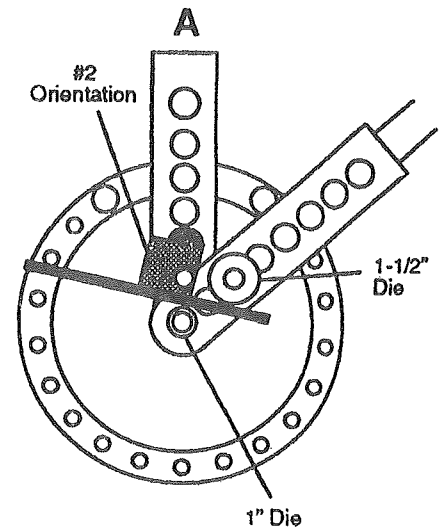

# Example: Bending Anchor Bolts and U-Bolts

## Anchor Bolts

To make a 10-in. long anchor bolt shown, from a 12¼-in. blank:

**NOTE:** To make another-length bolt, just use a shorter or longer blank. Or, change the dimension given in Step 3 below (being sure that enough material is caught by the block).

1. With a long hinge pin, attach the handle and ring loops at their center-pin holes. Install a 1-in. die on the center pin.

With the short hinge pin, install a 2-in. die in the handle (#2 hole).

2. With a long hinge pin, install the stop block. Orient the block appropriately for the diameter of the bolt blank: #2 orientation for ¾-in. or ½-in. bolts; #4 orientation for ⅝-in. bolts.
3. Insert the bolt blank into the Bender so that the **unthreaded** end extends beyond the stop block: ½-in. for ¾-in. bolts; ⅝-in. for ½-in. bolts; ¼-in. for ⅝-in. bolts.
4. Pull the handle around until the bolt shaft is 90° from the anchor.

TYPICAL U-BOLTS AND ANCHOR BOLTS

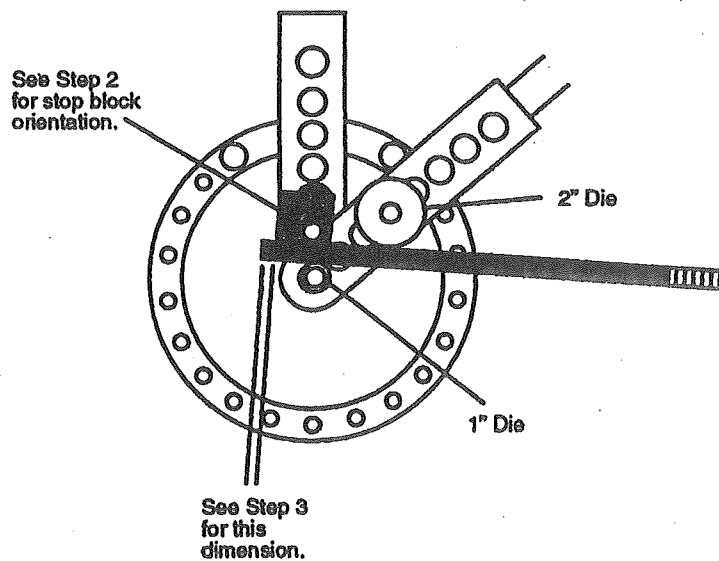
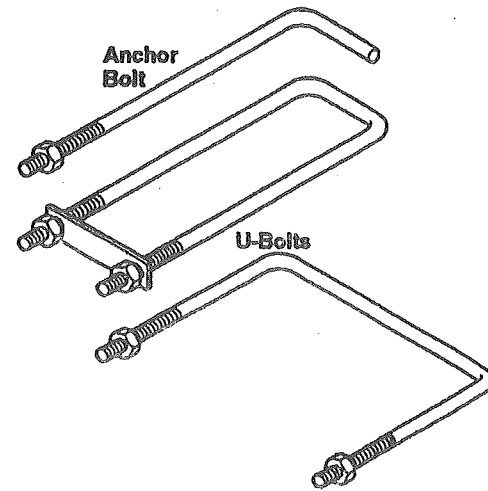

## Example: Bending Anchor Bolts and U-Bolts (continued)

### U-Bolts

The tables on pages 12 and 13 show the appropriate setup for making U-bolts in typical finished lengths and bend radiuses, from common diameters of round stock.

The illustration below shows the setup for making a U-bolt that is 3½-in. long and 2-in. I.D., using ⅝-in.-diameter stock. For other sizes, adjust the die sizes, stop block orientation, etc., as shown in the tables.

### Length

For longer U-bolts, add twice the additional length desired to the "blank length" indicated (for example, to make a U-bolt that is 1 in. longer, add 2 in. to the blank length).

### Bend Radius

Eight bend radiuses are possible—by selecting from the seven forming dies, or by using center pin without a die. However to avoid bending the center pin, always use a forming die with round stock larger than ⅝-in. diameter.

### Notes

- ◆ Because blank stock may vary slightly in content or size, we recommend making a test bend using unthreaded stock before you make a quantity of U-bolts.
- ◆ Keep a record of die sizes, die positions, and other measurements for future reference.

#### Typical Setup for Bending U-Bolts from Round Stock

(see tables on pages 12 and 13 for specific information)

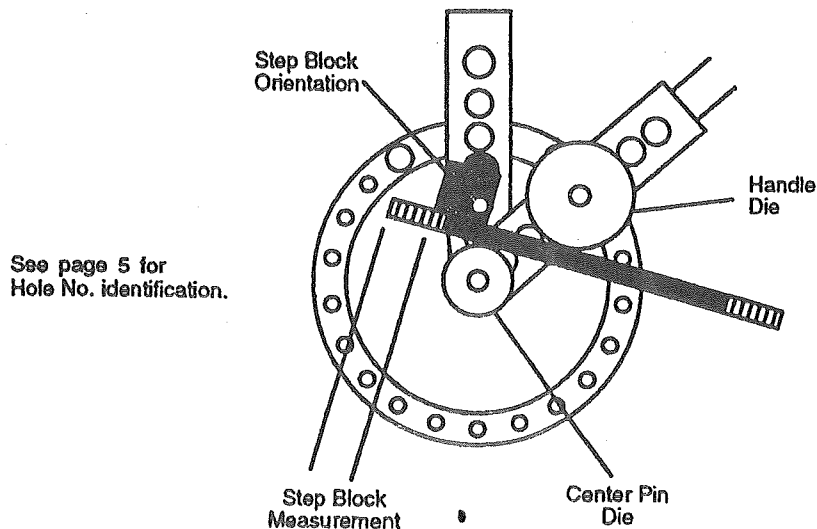

**Example: Bending Anchor Bolts and U-Bolts (continued)**

**Bending U-Bolts from 1/4-in. Round Stock**

FINISHED SIZE		SETUP FOR BENDING						
Length	I.D.	Blank Length	Loop Hole No.	Stop Block Orientation	Stop Block Meas't	Center Pin Die	Handle Die	Handle Hole No.
2"	1"	5"	1	#2	Flush	1"	2"	2
2 1/4"	1 1/4"	5 1/4"	1	#2	1/4"	1 1/4"	2"	2
2 1/2"	1 1/2"	6 3/8"	1	#1	3/8"	1 1/2"	2"	2
3"	1 3/4"	7 1/2"	2	#4	1/4"	1 1/4"	2"	2
3 1/2"	2"	8 5/8"	2	#4	7/8"	2"	1 3/4"	2

**Bending U-Bolts from 1/4-in. Round Stock**

FINISHED SIZE		SETUP FOR BENDING						
Length	I.D.	Blank Length	Loop Hole No.	Stop Block Orientation	Stop Block Meas't	Center Pin Die	Handle Die	Handle Hole No.
2 1/2"	1 1/4"	6 1/4"	1	#1	5/16"	1 1/4"	2"	2
3"	1 1/2"	7 3/8"	2	#4	1/4"	1 1/2"	2"	2
3"	1 3/4"	7 5/8"	2	#4	3/8"	1 3/4"	2"	2
3 1/2"	2"	8 3/4"	2	#4	15/16"	2"	2"	2

**Bending U-Bolts from 3/8-in. Round Stock**

FINISHED SIZE		SETUP FOR BENDING						
Length	I.D.	Blank Length	Loop Hole No.	Stop Block Orientation	Stop Block Meas't	Center Pin Die	Handle Die	Handle Hole No.
2 1/2"	1 1/4"	6 1/2"	1	#1	5/8"	1 1/4"	2"	2
3"	1 1/2"	7 1/2"	2	#4	7/16"	1 1/2"	3"	3
3"	1 3/4"	7 3/4"	2	#4	9/16"	1 3/4"	3"	3
3"	2"	8"	2	#3	1/8"	2"	3"	3

**Example: Bending Anchor Bolts and U-Bolts (continued)**

**Bending U-Bolts from 1/2-in. Round Stock**

FINISHED SIZE		SETUP FOR BENDING						
Length	I.D.	Blank Length	Loop Hole No.	Stop Block Orientation	Stop Block Meas't	Center Pin Die	Handle Die	Handle Hole No.
2 3/4"	1 1/2"	7 1/4"	2	#4	7/16"	1 1/2"	3"	3
3"	1 3/4"	8"	2	#4	15/16"	1 3/4"	3"	3
3 1/4"	2"	8 3/4"	2	#3	3/4"	2"	2 1/2"	3
4"	2 1/2"	10 1/8"	2	#2	1"	2 1/2"	2"	3
4 1/2"	3"	11 5/8"	3	#4	1"	3"	2"	3

**Bending U-Bolts from 5/8-in. Round Stock**

FINISHED SIZE		SETUP FOR BENDING						
Length	I.D.	Blank Length	Loop Hole No.	Stop Block Orientation	Stop Block Meas't	Center Pin Die	Handle Die	Handle Hole No.
3 1/2"	2"	9 1/4"	2	#2	1"	2"	3"	3
2 1/2"	2 1/2"	11 1/2"	2	#1	1 5/8"	2 1/2"	2"	3
5"	3"	12 3/4"	3	#4	1 7/8"	3"	2"	3

## Example: Bending Letters for Signs

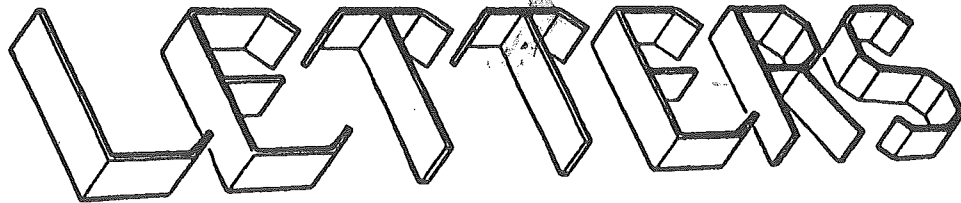

The following pages show how to make all 26 letters of the alphabet, in a typical style. Using the procedure that is shown on these pages results in letters (from  $\frac{3}{16}$ -in. flat stock) which are:

- ◆ 6 in. high
- ◆ 2 in. wide (deep)

### Notes

- ◆ Use only hot-rolled mild steel for forming the letters.
- ◆ Follow the bending steps exactly, and in the sequence given. This is especially important for the letter "S", which is the most difficult to form.
- ◆ To avoid wasting material, practice some of the letters using  $\frac{3}{16}$ -in. stock that is only  $\frac{1}{2}$ -in. wide before you attempt the finished version.
- ◆ If you have two or more identical letters, make all of them before proceeding to a different letter.

## Example: Bending Letters for Signs (continued)

### STOCK REQUIRED

$\frac{3}{16}$ -in. stock; 2-in. max. width

One 14-in. blank

One 3½-in. blank

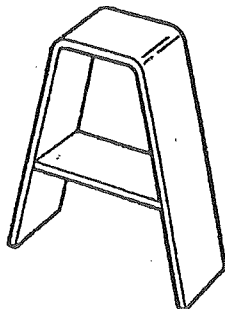

### BEND SEQUENCE

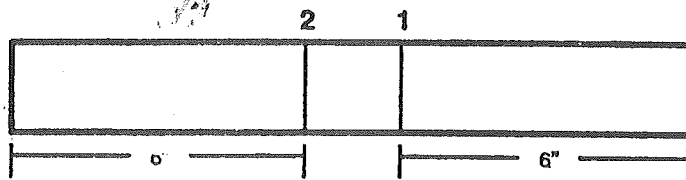

### Setup

Make chalk marks on the 14-in. blank as shown on the "Bend Sequence."

### Bend No. 1

Insert the stock into the Bender to the #1 chalk mark (as in A), and bend it to 76°. Recheck the angle before you go on to the second bend.

### Bend No. 2

Slide the stock to the #2 chalk mark (as in B), and bend it to 76°. Recheck the angle.

To remove the part from the Bender, remove the pin that holds the sharp-angle-bend attachment.

### Finishing

Tack-weld the 3½-in. insert piece between the legs of the "A," parallel to the top edge.

Grind and sand all sharp corners.

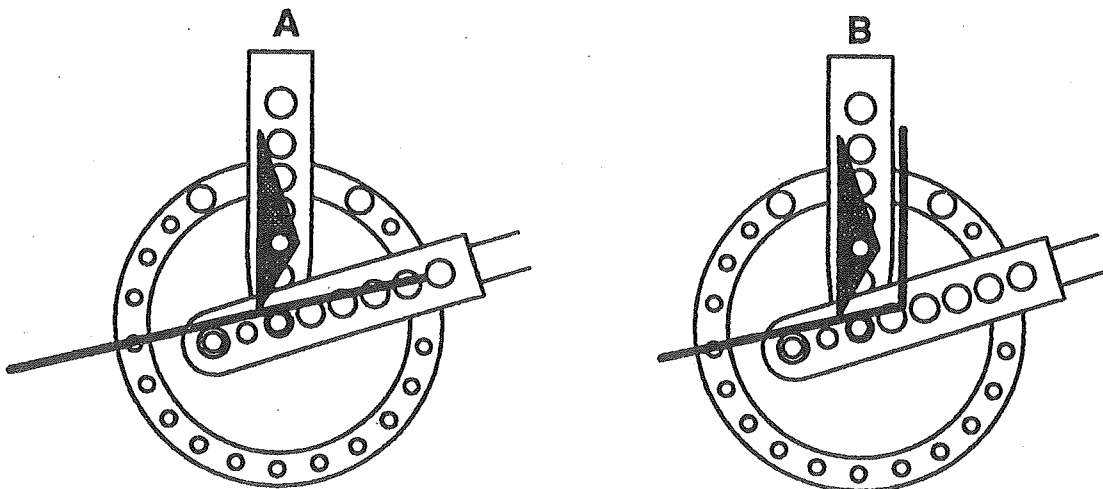



## Example: Bending Letters for Signs (continued)

### STOCK REQUIRED

$\frac{3}{16}$ -in. stock; 2-in. max. width

One  $8\frac{7}{8}$ -in. blank  
One 6-in. blank

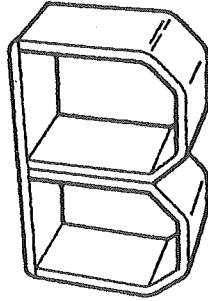

### BEND SEQUENCE

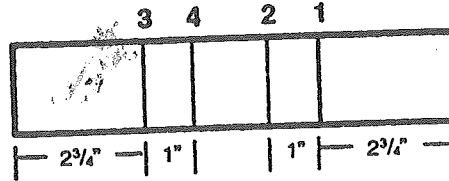

Two pieces,  
 $8\frac{7}{8}$ " each

### Setup

Make chalk marks on the two  $8\frac{7}{8}$ -in. blanks as shown on the "Bend Sequence."

### Bend No. 1

Insert one of the blanks into the Bender to the #1 chalk mark (as in A), and bend it to 45°. Recheck the angle before you go on to the second bend.

Chalk-mark the ring, or set a stop, for ease of repeating the 45° bend.

### Bend No. 2

Slide the stock to the #2 chalk mark (as in B), and bend it to 45°. Recheck the angle.

### Bend No. 3

Reverse the stock end-for-end. Slide it to the #3 chalk mark (as in C), and bend it to 45°. Recheck the angle.

### Bend No. 4

Again reverse the stock end-for-end. Move it to the #4 chalk mark (as in D), and bend it to 45°. Recheck the angle.

To remove the part from the Bender, remove the pin that holds the sharp-angle-bend attachment.

### Finishing

Tack-weld the two loops together. Tack-weld the 6 in. piece to form the back of the letter "B".

Grind and sand all sharp corners.

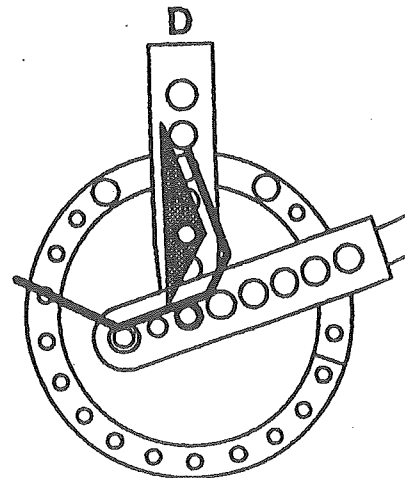
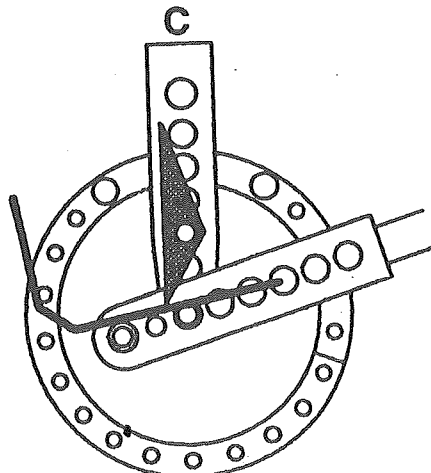
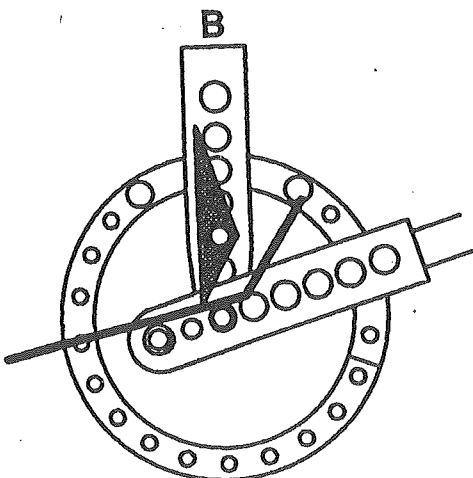
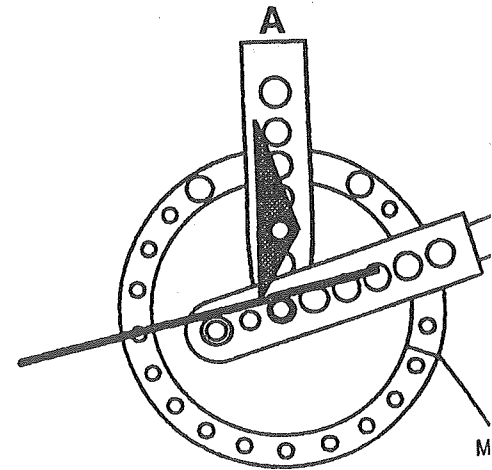

## Example: Bending Letters for Signs (continued)

### STOCK REQUIRED

$\frac{3}{16}$ -in. stock; 2-in. max. width

One 14-in. blank

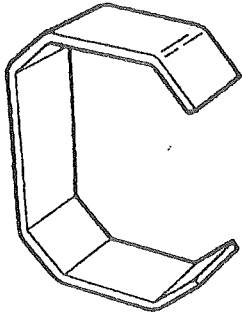

### STOCK REQUIRED

$\frac{3}{16}$ -in. stock; 2-in. max. width

One 14-in. blank

### BEND SEQUENCE

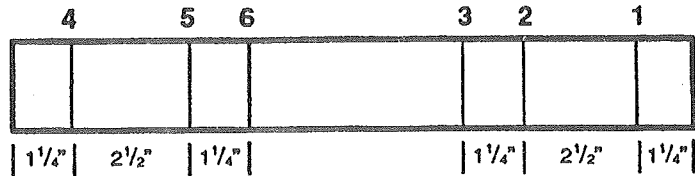

### Setup

Make chalk marks on the 14-in. blank as shown on the "Bend Sequence."

### Bend No. 1

Insert the stock into the Bender to the #1 chalk mark (as in **A**), and bend it to 45°. Recheck the angle before you go on to the second bend.

### Bend No. 2

Slide the stock to the #2 chalk mark (as in **B**), and bend it to 45°. Recheck the angle.

### Bend No. 3

Slide the stock to the #3 chalk mark (as in **C**), and bend it to 45°. Recheck the angle.

### Finishing

Reverse the stock end-for-end. Slide it to the #4 chalk mark (as in **D**), and bend it to 45°. Recheck the angle.

*(continued on next page)*

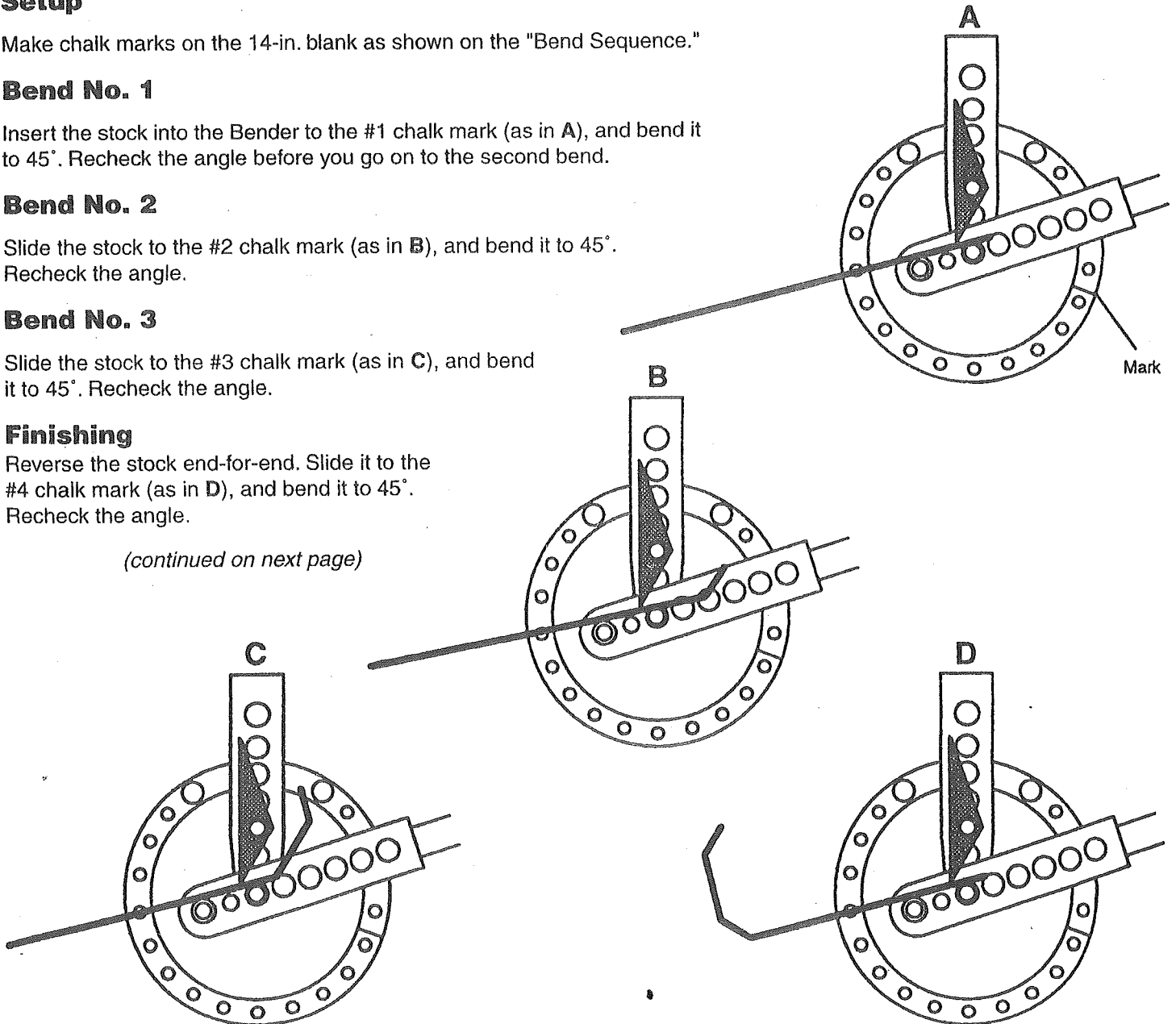

## Example: Bending Letters for Signs (continued)

### Bend No. 5

Slide the stock to the #5 chalk mark (as in E), and bend it to 45°. Recheck the angle.

### Bend No. 6

Slide the stock to the #6 chalk mark (as in F), and bend it to 45°. Recheck the angle.

To remove the part from the Bender, remove the pin that holds the sharp-angle-bend attachment.

### Finishing

Grind and sand all sharp corners.

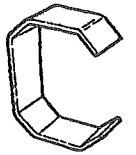

Continued

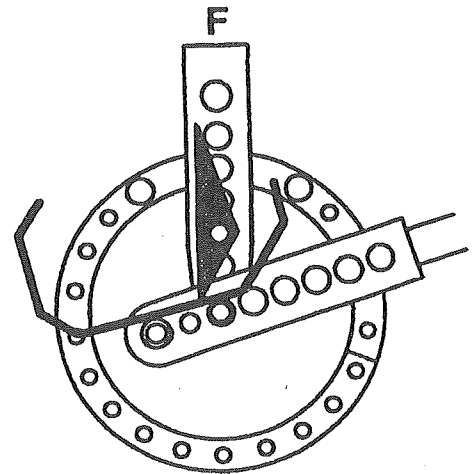
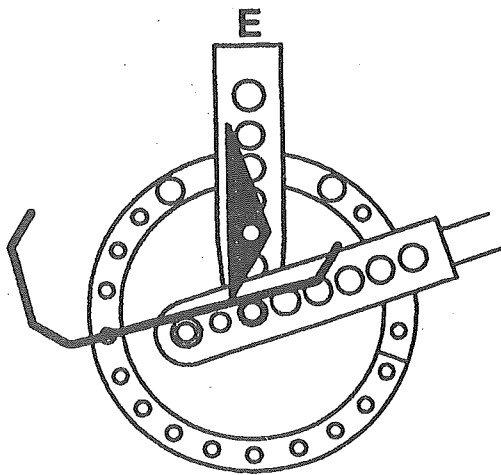

### STOCK REQUIRED

$\frac{3}{16}$ -in. stock; 2-in. max. width

One 12 $\frac{1}{8}$ -in. blank

One 6-in. blank

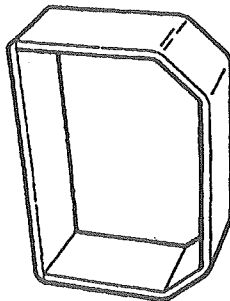

### BEND SEQUENCE

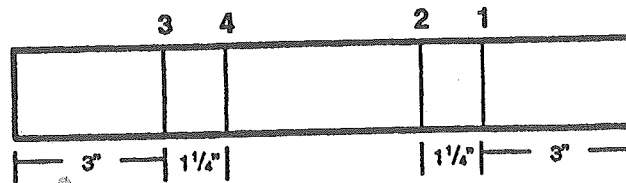

### Setup

Make chalk marks on the two 12 $\frac{1}{8}$ -in. blank as shown on the "Bend Sequence."

(continued on next page)

## Example: Bending Letters for Signs (continued)

### Bend No. 1

Insert the blank into the Bender to the #1 chalk mark (as in A), and bend it to 45°. Recheck the angle before you go on to the second bend.

Chalk-mark the ring, or set a stop, for ease of repeating the 45° bend.

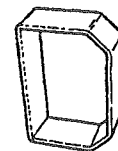

Continued

### Bend No. 2

Slide the stock to the #2 chalk mark (as in B), and bend it to 45°. Recheck the angle.

Remove the blank from the Bender. Recheck that the bend leg is at 90° to the front of the "D".

### Bend No. 3

Reverse the stock end-for-end. Slide it to the #3 chalk mark (as in C), and bend it to 45°. Recheck the angle.

### Bend No. 4

Slide the stock to the #4 chalk mark (as in D), and bend it to 45°. Recheck the angle. Recheck that the two legs are parallel.

To remove the part from the Bender, remove the pin that holds the sharp-angle-bend attachment.

### Finishing

Tack-weld the 6 in. piece to form the back of the letter "D".

Grind and sand all sharp corners.

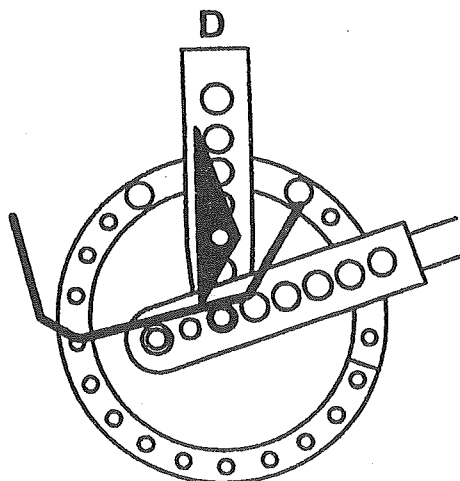
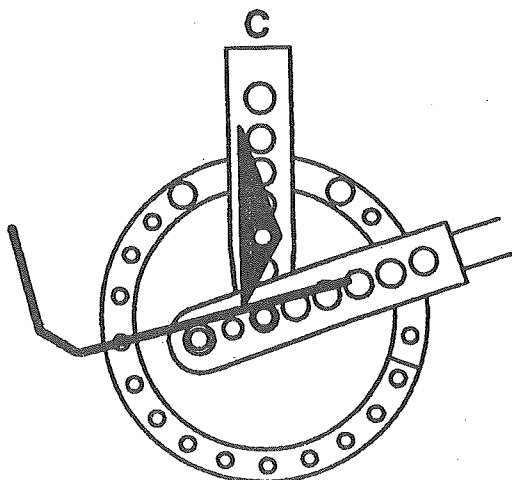
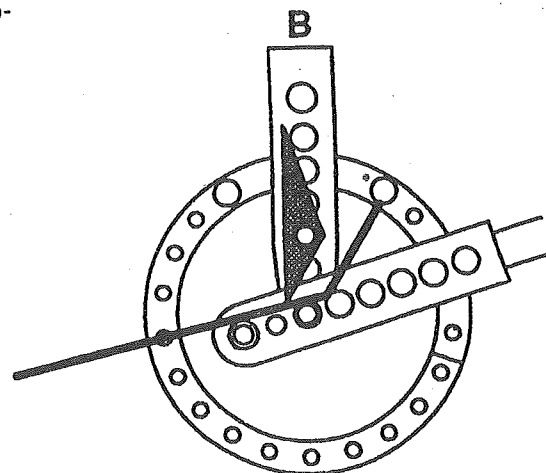
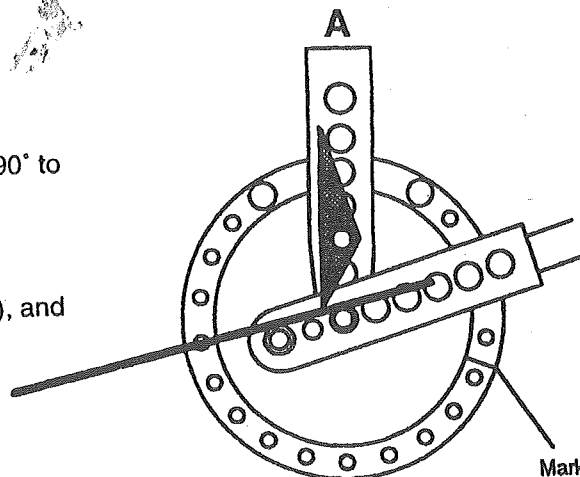

## Example: Bending Letters for Signs (continued)

### STOCK REQUIRED

$\frac{7}{16}$ -in. stock; 2-in. max. width

One  $14\frac{9}{16}$ -in. blank

One  $2\frac{1}{2}$ -in. blank

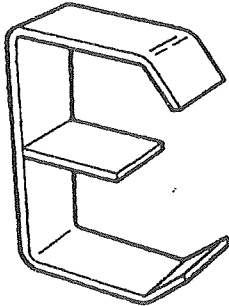

### BEND SEQUENCE

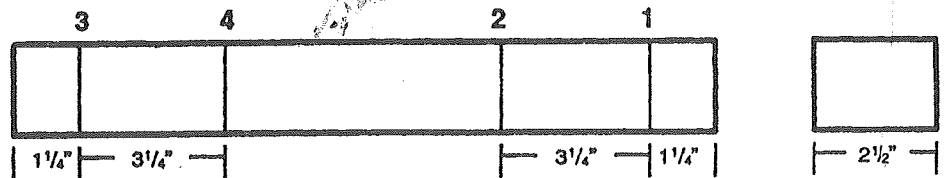

### Setup

Make chalk marks on the  $14\frac{9}{16}$ -in. blank as shown on the "Bend Sequence."

### Bend No. 1

Insert the blank into the Bender to the #1 chalk mark (as in A), and bend it to  $45^\circ$ . Recheck the angle before you go on to the second bend.

### Bend No. 2

Slide the stock to the #2 chalk mark (as in B), and bend it to  $90^\circ$ . Recheck the angle.

### Bend No. 3

Reverse the stock end-for-end. Slide it to the #3 chalk mark (as in C), and bend it to  $45^\circ$ . Recheck the angle.

### Bend No. 4

Slide the stock to the #4 chalk mark (as in D), and bend it to  $90^\circ$ . Recheck the angle. Check that the top and bottom of the "E" are parallel.

To remove the part from the Bender, remove the pin that holds the sharp-angle-bend attachment.

### Finishing

Tack-weld the  $3\frac{1}{2}$ -in. insert piece between the legs of the "A," parallel to the top edge.

Grind and sand all sharp corners.

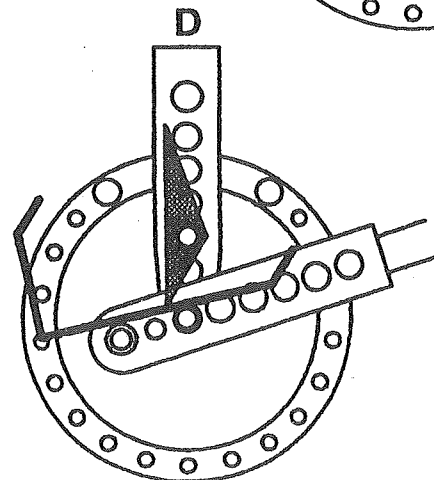
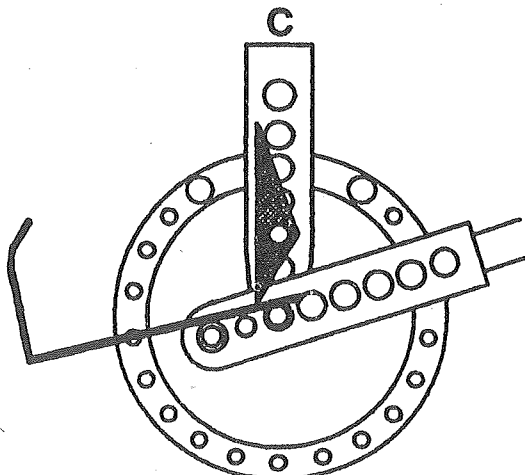
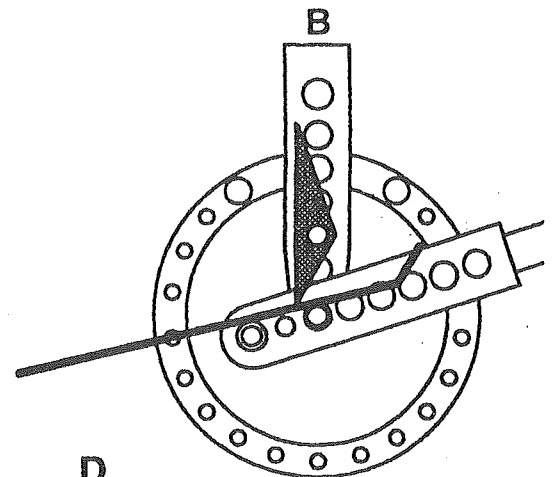
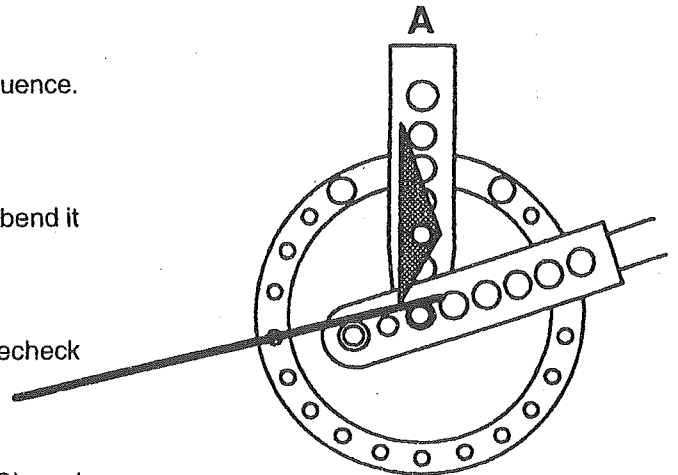

## Example: Bending Letters for Signs (continued)

### STOCK REQUIRED

$\frac{3}{16}$ -in. stock; 2-in. max. width

One  $10\frac{1}{2}$ -in. blank

One  $2\frac{1}{2}$ -in. blank

### Setup

Make a letter "L" as shown on page 24.

### Finishing

Position the  $2\frac{1}{2}$ -in. piece as shown and tack-weld it.

Grind and sand all sharp corners.

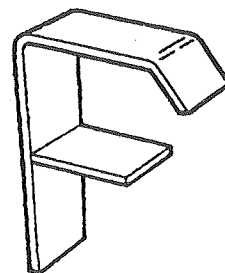
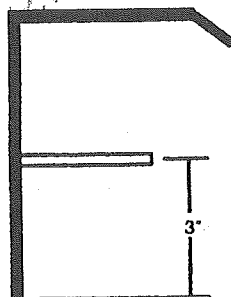

### STOCK REQUIRED

$\frac{3}{16}$ -in. stock; 2-in. max. width

One 14-in. blank

One 3-in. blank

### BEND

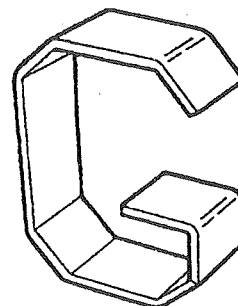
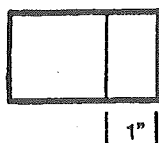

### Setup

Make a letter "C" as shown on page 17.

### Bend

Insert the 3-in. blank into the Bender to the chalk mark, and bend it to 90°. Recheck the angle.

To remove the part from the Bender, remove the pin that holds the sharp-angle-bend attachment.

### Finishing

Position the 3-in. piece as shown and tack-weld it.

Grind and sand all sharp corners.

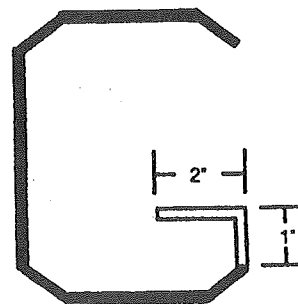

## Example: Bending Letters for Signs (continued)

### STOCK REQUIRED

$\frac{7}{16}$ -in. stock; 2-in. max. width

Two 6-in. blanks

One  $3\frac{1}{4}$ -in. blank

### Setup

None.

### Finishing

Tack-weld the pieces together as shown. Recheck that the pieces are at 90° angles to each other.

Grind and sand all sharp corners.

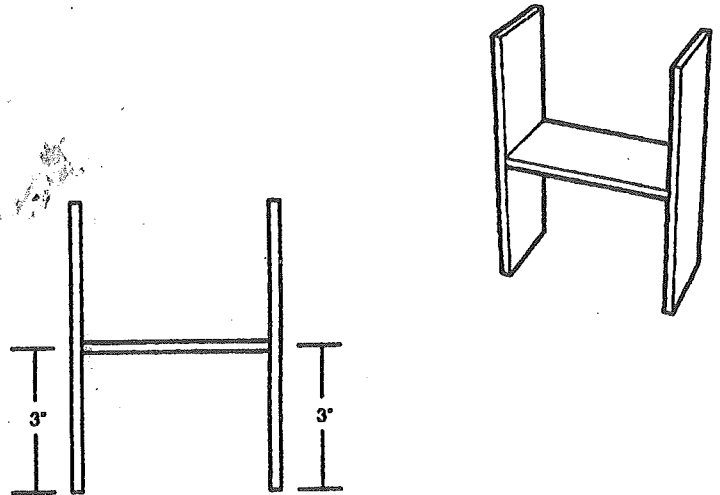

### STOCK REQUIRED

$\frac{7}{16}$ -in. stock; 2-in. max. width

Two 5-in. blanks

One  $5\frac{1}{2}$ -in. blank

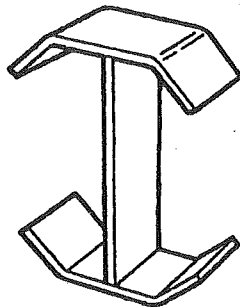

### BEND SEQUENCE (5-in. blanks)

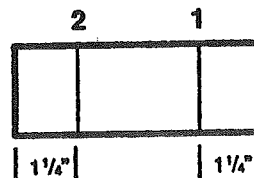

### Setup

Make chalk marks on the 5-in. blanks as shown on the "Bend Sequence."

### Bend No. 1

Insert the blank into the Bender to the #1 chalk mark, and bend it to 45°. Recheck the angle.

Chalk mark the ring, or set a stop, for ease of repeating the 45° bend.

### Bend No. 2

Reverse the stock end-for-end. Slide it to the #2 chalk mark, and bend it to 45°. Recheck the angle.

To remove the part from the Bender, remove the pin that holds the sharp-angle-bend attachment.

### Finishing

Position the  $5\frac{1}{2}$ -in. piece between the bent pieces as shown and tack-weld it. Recheck that the parts are 90°.

Grind and sand all sharp corners.

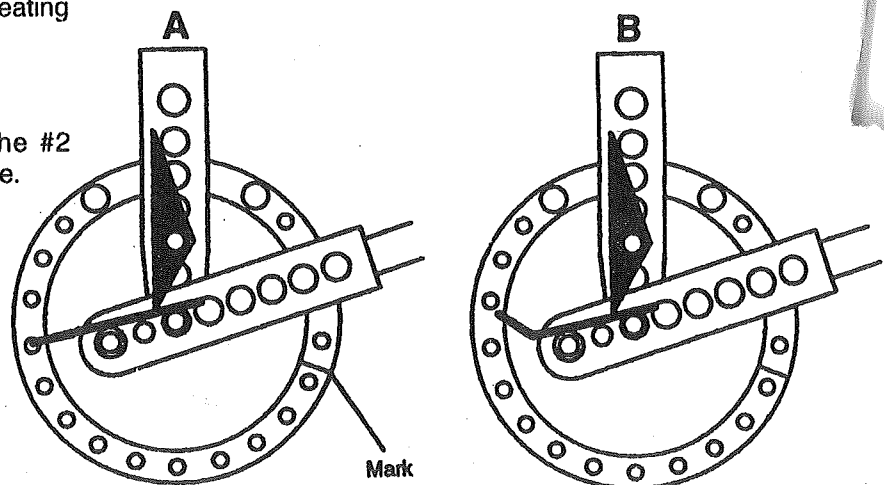

## Example: Bending Letters for Signs (continued)

### STOCK REQUIRED

$\frac{3}{16}$ -in. stock; 2-in. max. width

One 10-in. blank

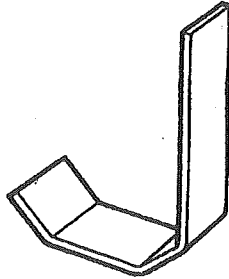

### BEND SEQUENCE

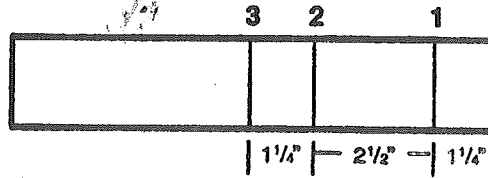

### Setup

Make chalk marks on the blanks as shown on the "Bend Sequence."

### Bend No. 1

Insert the blank into the Bender to the #1 chalk mark, (as in A), and bend it to 45°. Recheck the angle before you go on to the second bend.

Chalk mark the ring, or set a stop, for ease of repeating the 45° bend.

### Bend No. 2

Slide the stock to the #2 chalk mark (as in B), and bend it to 45°. Recheck the angle.

### Bend No. 3

Slide the stock to the #3 chalk mark (as in C), and bend it to 45°. Recheck the angle.

To remove the part from the Bender, remove the pin that holds the sharp-angle-bend attachment.

### Finishing

Grind and sand all sharp corners.

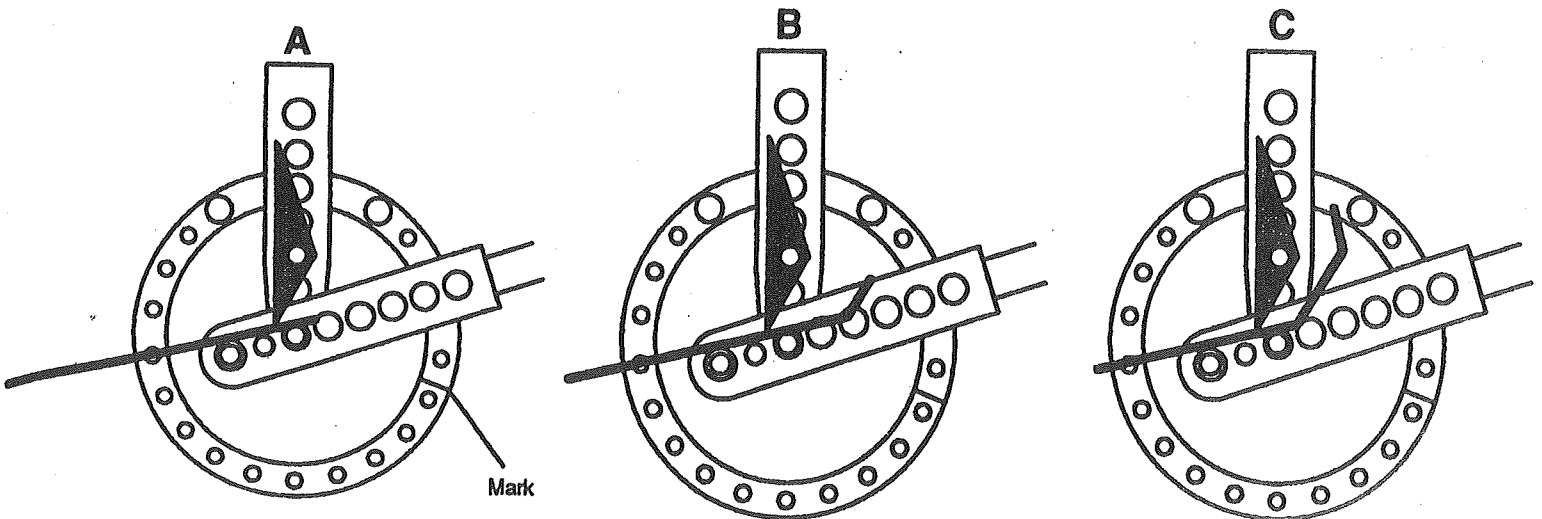



## Example: Bending Letters for Signs (continued)

### STOCK REQUIRED

$\frac{3}{16}$ -in. stock; 2-in. max. width

One 7-in. blank  
One 6-in. blank  
One 2½-in. blank

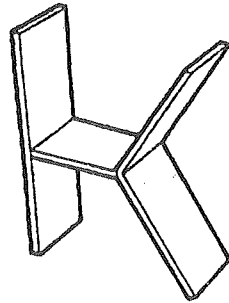

BEND (7-in. blank)

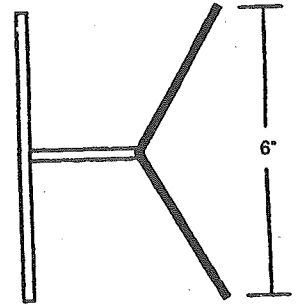
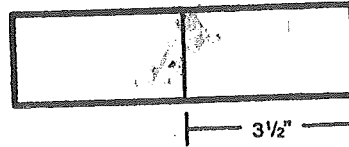

### Setup

Make chalk marks on the 7-in. blanks as shown on the "Bend Sequence."

### Bend

Insert the blank into the Bender to the chalk mark, and bend until it measures 6 in. as shown.

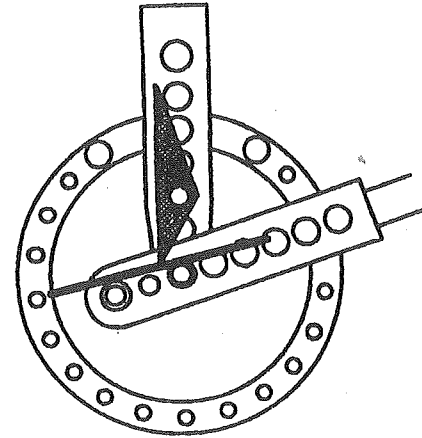

### Finishing

Tack-weld the pieces together as shown. Recheck that the outer tips of the bent piece are equal distances from the straight piece. Grind and sand all sharp corners.

### STOCK REQUIRED

$\frac{3}{16}$ -in. stock; 2-in. max. width

One 10½-in. blank

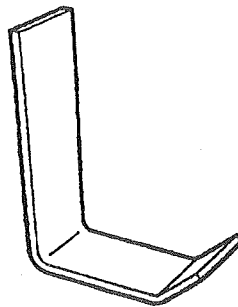

BEND SEQUENCE

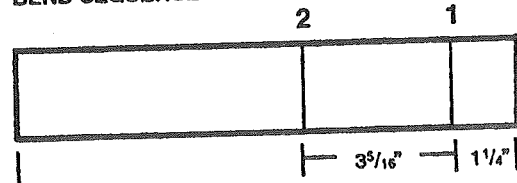

### Setup

Make chalk marks on the blanks as shown on the "Bend Sequence."

### Bend No. 1

Insert the blank into the Bender to the #1 chalk mark, and bend it to 45°. Recheck the angle.

### Bend No. 2

Slide the stock to the #2 chalk mark, and bend to 90°. Recheck the angle.

To remove the part from the Bender, remove the pin that holds the sharp-angle-bend attachment.

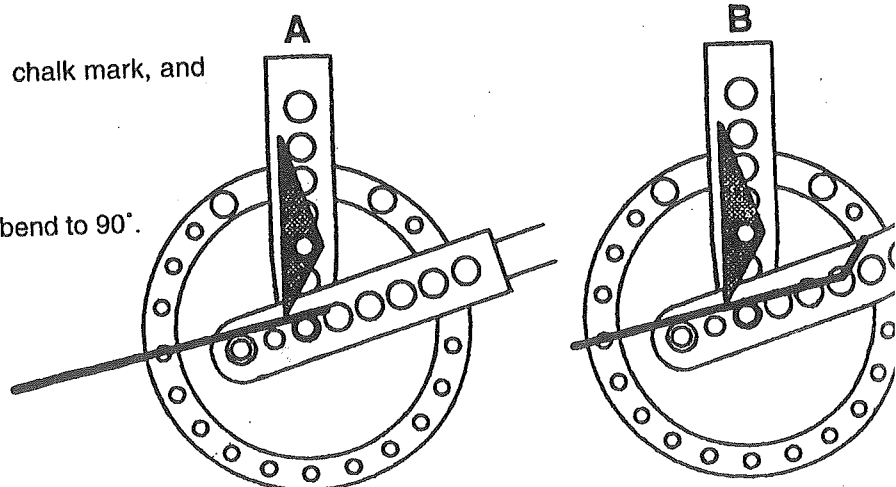

### Finishing

Grind and sand all sharp corners.

## Example: Bending Letters for Signs (continued)

### STOCK REQUIRED

$\frac{3}{16}$ -in. stock; 2-in. max. width

Two 13½-in. blanks

### Setup

Make two letter "V"s as shown on page 32.

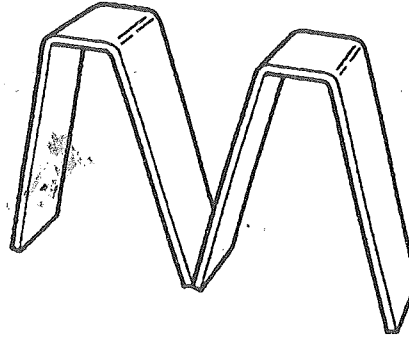

### Finishing

Turn the "V"s upside-down, and tack-weld them together as shown.

Check that the three bottom tips are aligned.

Grind and sand all sharp corners.

---

### STOCK REQUIRED

$\frac{3}{16}$ -in. stock; 2-in. max. width

One 8½-in. blank

Two 6-in. blanks

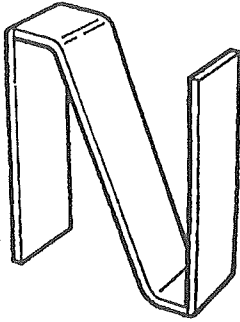

BEND SEQUENCE (8½-in. blank)

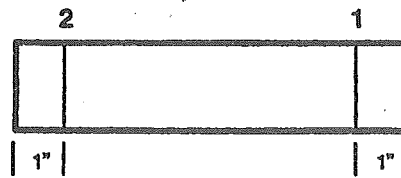

### Setup

Make chalk marks on the 8½-in. blanks as shown on the "Bend Sequence."

### Bend No. 1

Insert the blank into the Bender to the #1 chalk mark, (as in A), and bend it to 73°. Recheck the angle.

### Bend No. 2

Reverse the stock end-for-end. Slide it to the #2 chalk mark, and bend it to 73°. Recheck the angle.

To remove the part from the Bender, remove the pin that holds the sharp-angle-bend attachment.

### Finishing

Tack-weld the pieces together. Recheck that the straight legs are parallel.

Grind and sand all sharp corners.

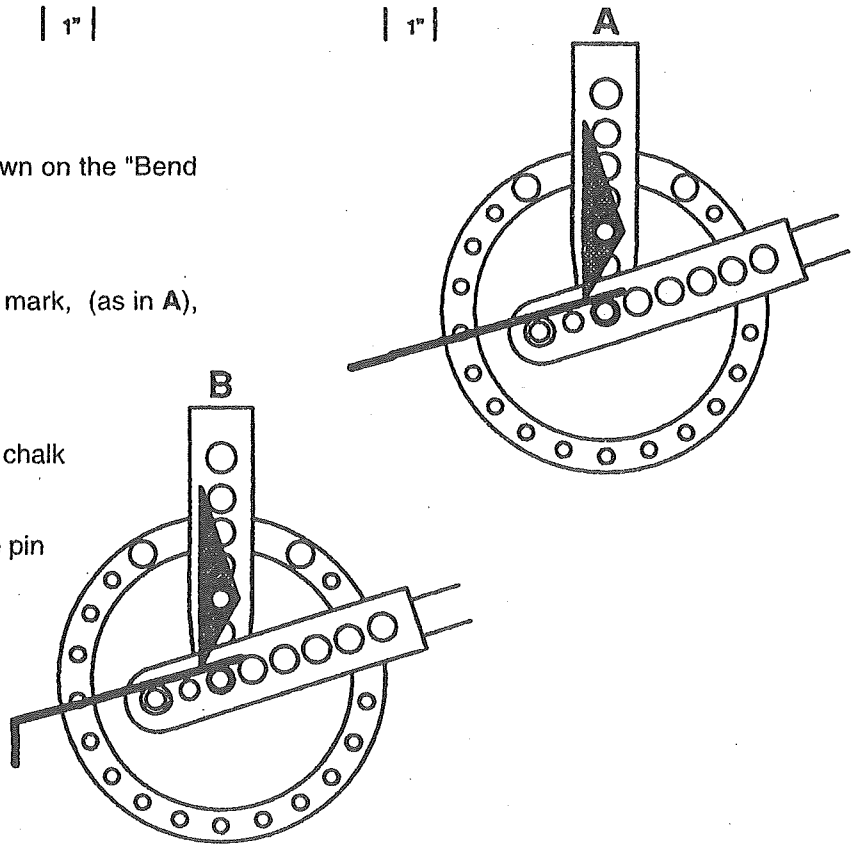

## Example: Bending Letters for Signs (continued)

### STOCK REQUIRED

$\frac{3}{16}$ -in. stock; 2-in. max. width

- One 14-in. blank
- One  $\frac{3}{8}$ -in. blank

### Setup

Make a letter "C" from the 14-in. blank as shown on page 17.

### Finishing

Tack-weld the two pieces together as shown.  
Grind and sand all sharp corners.

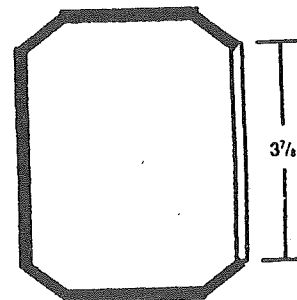
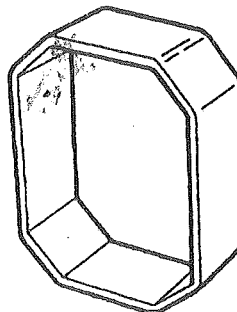

### STOCK REQUIRED

$\frac{3}{16}$ -in. stock; 2-in. max. width

- One  $8\frac{1}{8}$ -in. blank
- One 6-in. blank

### Setup

Make part of a letter "B" (page 16)—the straight piece and one loop.

### Finishing

Tack-weld the pieces together.  
Grind and sand all sharp corners.

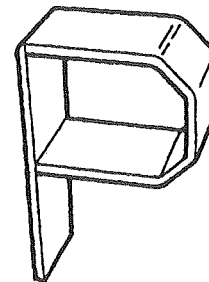

### STOCK REQUIRED

$\frac{3}{16}$ -in. stock; 2-in. max. width

- One 14-in. blank
- One  $\frac{3}{8}$ -in. blank
- One 2-in. blank
- One  $\frac{3}{4}$ -in. blank

### Setup

Make a letter "O" (above).

### Finishing

Tack-weld the short pieces to the "O" as shown above.  
Grind and sand all sharp corners.

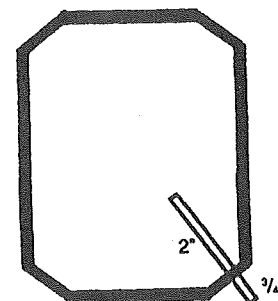
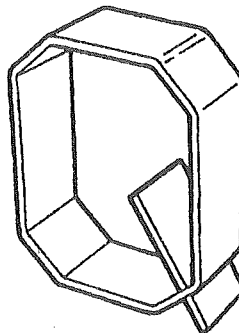

## Example: Bending Letters for Signs (continued)

### STOCK REQUIRED

3/8-in. stock; 2-in. max. width

One 8 7/8-in. blank

One 6-in. blank

One 3 1/8-in. blank

### Setup

Make part of a letter "P" (page 26).

### Finishing

Tack-weld the 3 1/8-in. piece to the "P" as shown.

Grind and sand all sharp corners.

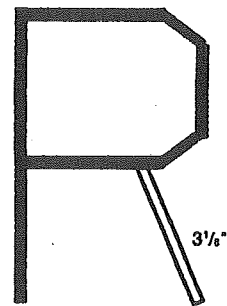
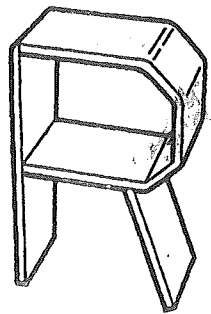

### STOCK REQUIRED

3/8-in. stock; 2-in. max. width

One 16 1/2-in. blank

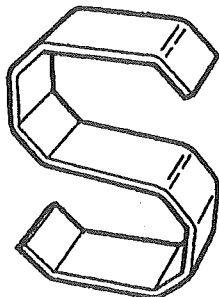

### BEND SEQUENCE

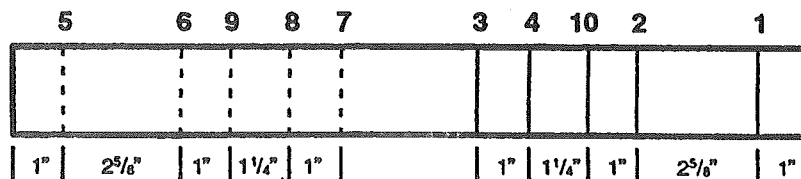

**CAUTION:** Because of the number of bends, it is especially important to check all bend angles carefully when making the letter "S."

### Setup

Make chalk marks on the blank as shown on the "Bend Sequence."

" Note that the five chalk marks on one end of the blank must be on the opposite face from the five marks on the other end.

### Bend No. 1

Insert the blank into the Bender to the #1 chalk mark (as in A), and bend it to 45°. Recheck the angle.

Chalk-mark the ring, or set a stop, for ease of repeating the 45° bend. (Note that Bends #3 and #7 are to 41°.)

### Bend No. 2

Slide the blank to the #2 chalk mark (as in B), and bend it to 45°.

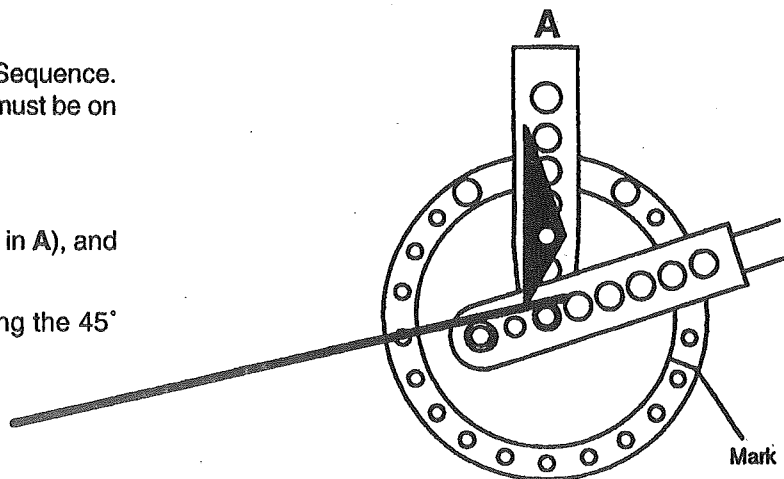

(continued on next page)

## Example: Bending Letters for Signs (continued)

### Bend No. 3

Slide the blank to the #3 chalk mark (as in C), and bend it to 41°. Recheck the angle.

### Bend No. 4

Slide the blank back to the #4 chalk mark (as in D), and bend it to 45°.

### Bend No. 5

Reverse the stock end-for-end. Slide the blank to the #5 chalk mark (as in E), and bend it to 45°. Recheck the angle.

### Bend No. 6

Slide the blank back to the #6 chalk mark (as in F), and bend it to 45°. Recheck the angle.

*(continued on next page)*

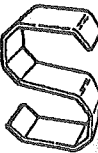

Continued

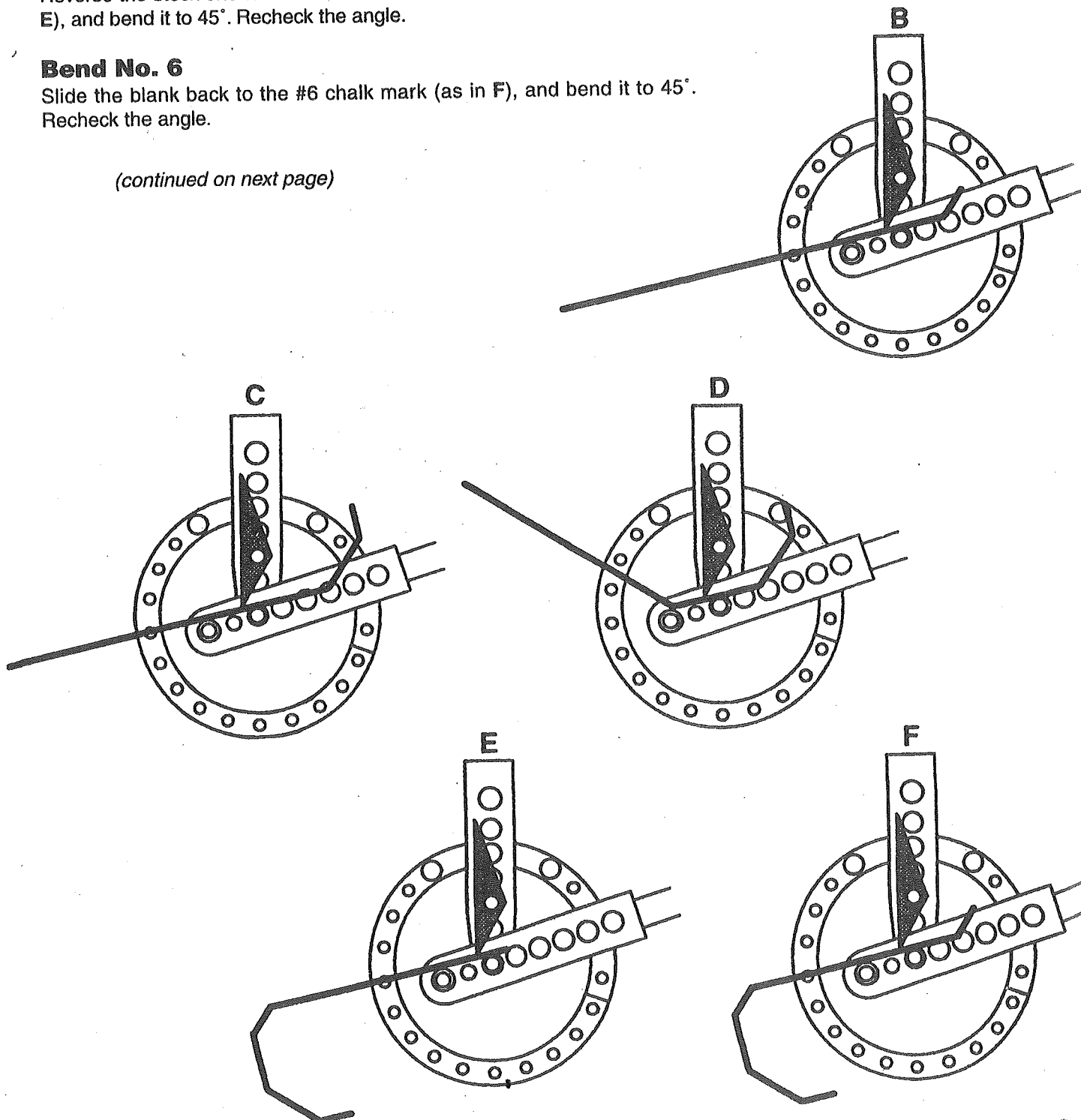

## Example: Bending Letters for Signs (continued)

### Bend No. 7

Slide the blank to the #7 chalk mark (as in G), and bend it to 41°. Recheck the angle.

### Bend No. 8

Slide the blank back to the #8 chalk mark (as in H), and bend it to 45°. Recheck the angle.

### Bend No. 9

Reverse the stock end-for-end. Pull the pin in the sharp-angle-bend attachment to allow space for the blank. Insert the blank, and reinstall the pin.

Slide the blank to the #9 chalk mark (as in I), and bend it to 45°. Recheck the angle.

### Bend No. 10

Again reverse the stock end-for-end. Slide the blank to the #10 chalk mark (as in J), and bend it to 45°. Recheck the angle, and check that the top and bottom of the "S" are parallel.

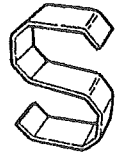

*Continued*

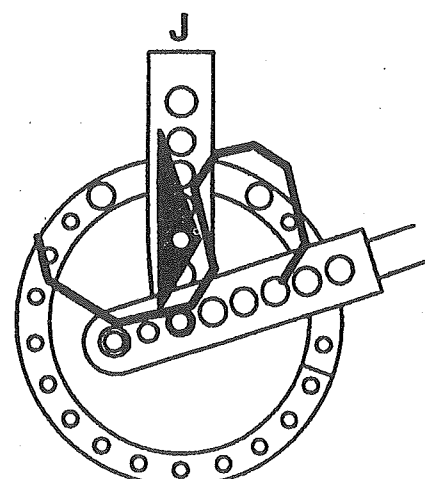
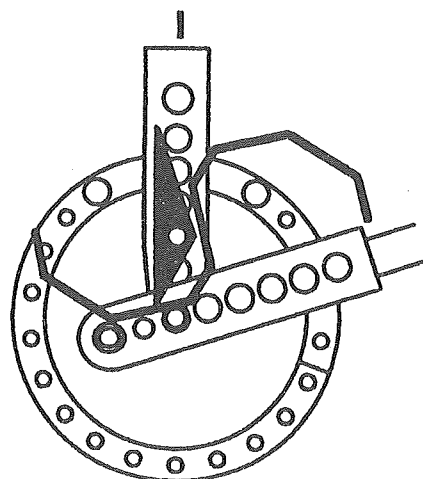
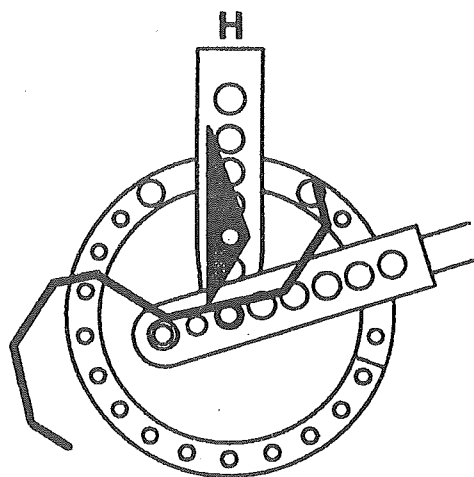
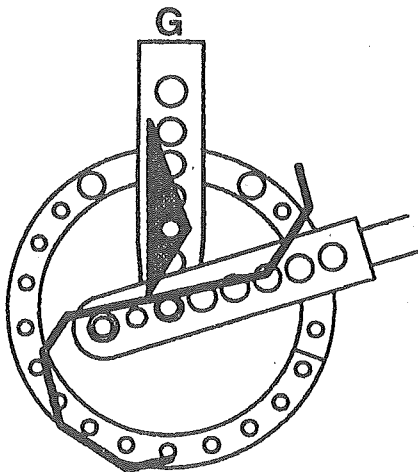

## Example: Bending Letters for Signs (continued)

### STOCK REQUIRED

$\frac{3}{16}$ -in. stock; 2-in. max. width

One 6-in. blank

One  $5\frac{13}{16}$ -in. blank

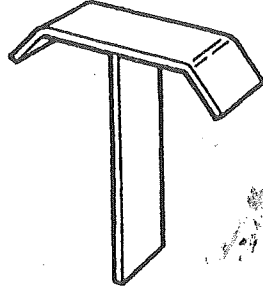

### BEND SEQUENCE ( $5\frac{13}{16}$ -in. blank)

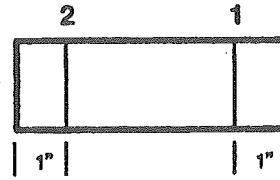

### Setup

Make chalk marks on the  $5\frac{13}{16}$ -in. blank as shown on the "Bend Sequence."

### Bend No. 1

Insert the blank into the Bender to the #1 chalk mark (as in A), and bend it to  $45^\circ$ . Recheck the angle.

Chalk mark the ring, or set a stop, for ease of repeating the  $45^\circ$  bend.

### Bend No. 2

Reverse the stock end-for-end. Slide it to the #2 chalk mark (as in B), and bend it to  $45^\circ$ . Recheck the angle.

### Finishing

Grind and sand all sharp corners.

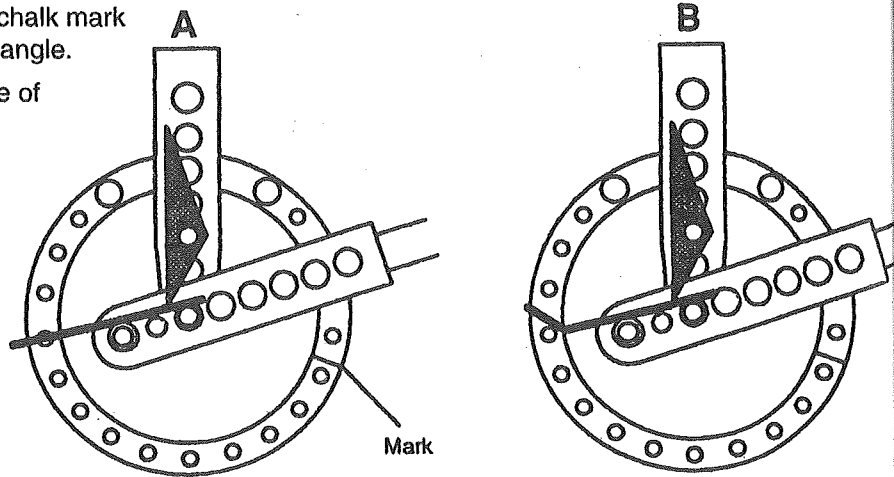

### STOCK REQUIRED

$\frac{3}{16}$ -in. stock; 2-in. max. width

One  $14\frac{1}{4}$ -in. blank

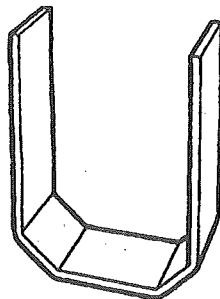

### BEND SEQUENCE

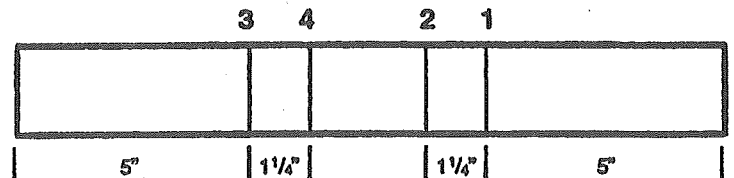

### Setup

Make chalk marks on the blank as shown on the "Bend Sequence."

(continued on next page).

## Example: Bending Letters for Signs (continued)

### Bend No. 1

Insert the blank into the Bender to the #1 chalk mark, (as in A), and bend it to 45°. Recheck the angle.

Chalk-mark the ring, or set a stop, for ease of repeating the 45° bend.

### Bend No. 2

Slide the blank to the #2 chalk mark (as in B), and bend it to 45°. Recheck the angle.

### Bend No. 3

Reverse the stock end-for-end. Slide it to the #3 chalk mark (as in C), and bend it to 45°. Recheck the angle.

### Bend No. 4

Slide the stock to the #4 chalk mark (as in D), and bend it to 45°. Recheck the angle, and check that the legs of the "U" are parallel.

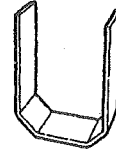

Continued

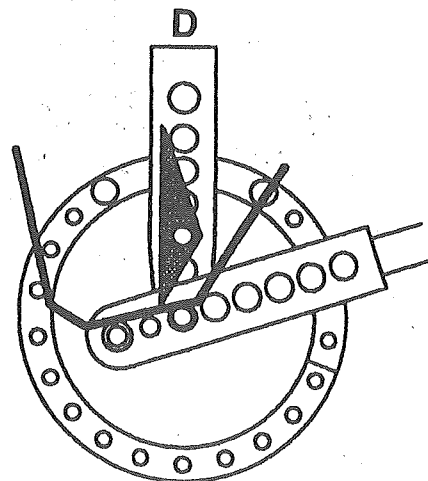
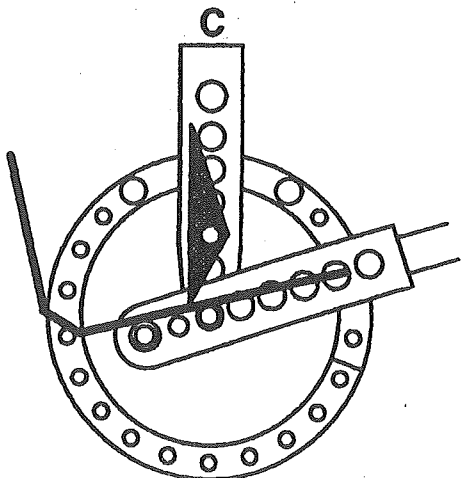
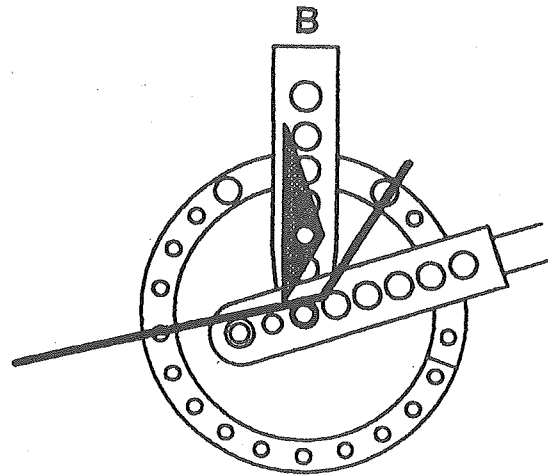
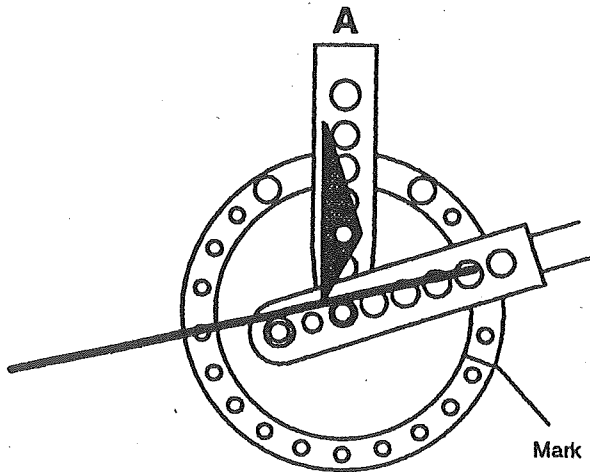

Grind and sand all sharp corners.



## Example: Bending Letters for Signs (continued)

### STOCK REQUIRED

$\frac{3}{16}$ -in. stock; 2-in. max. width

One 13 $\frac{1}{2}$ -in. blank

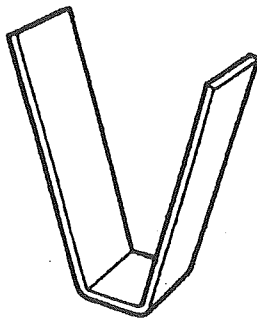

### BEND SEQUENCE

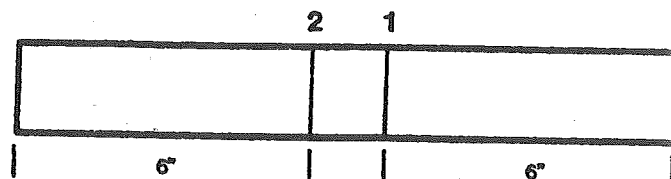

### Setup

Make chalk marks on the 5 $\frac{13}{16}$ -in. blank as shown on the "Bend Sequence."

### Bend No. 1

Insert the blank into the Bender to the #1 chalk mark (as in A), and bend it to 75°.

### Bend No. 2

Slide the blank to the #2 chalk mark (as in B), and bend it to 75°. To remove the part, pull the pin in the sharp-angle-bend attachment.

### Finishing

Grind and sand all sharp corners.

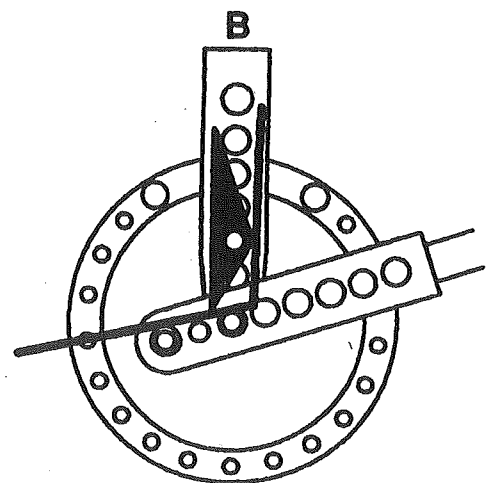
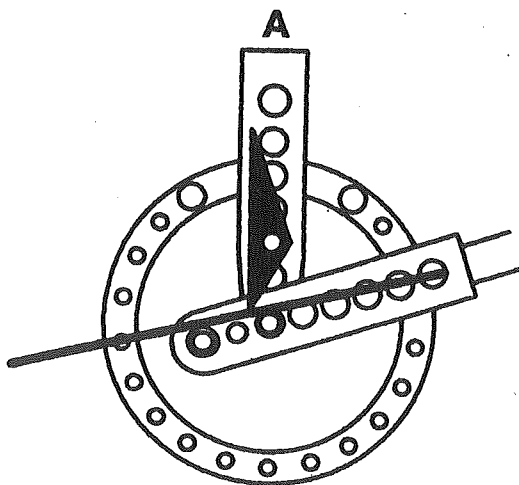

## Example: Bending Letters for Signs (continued)

### STOCK REQUIRED

$\frac{3}{16}$ -in. stock; 2-in. max. width

Two 13½-in. blank

Make the letter "W" by tack-welding together two letter "V"s (the same as a letter "M"—page 26).

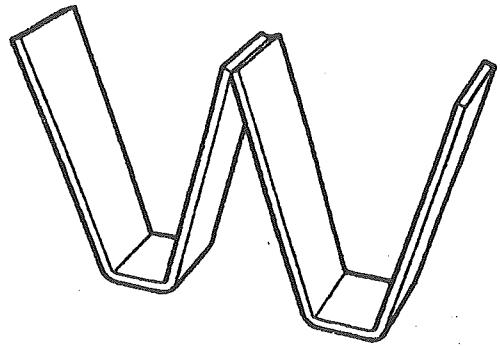

### STOCK REQUIRED

$\frac{3}{16}$ -in. stock; 2-in. max. width

Two 7½-in. blanks

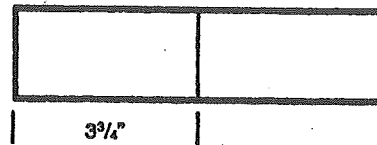
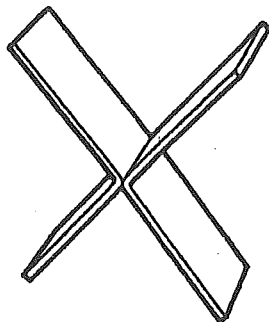

### Setup

Make chalk marks on the blank as shown on the "Bend Sequence."

### Bend

Insert the blank into the Bender to the chalk mark, and bend it until the outside dimension is 6 in. (as shown).

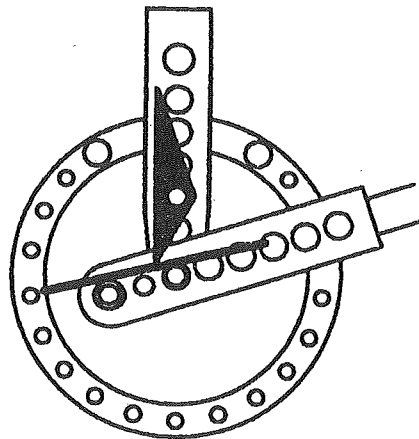

### Finishing

Tack-weld the two pieces together. Check that the parts are parallel.

Grind and sand all sharp corners.

### STOCK REQUIRED

$\frac{3}{16}$ -in. stock; 2-in. max. width

One 9½-in. blank

One 3¾-in. blank

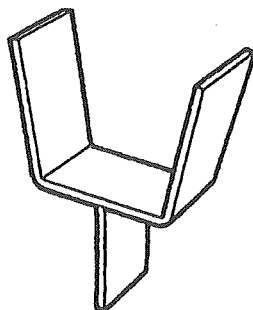

### BEND SEQUENCE (9½-in. blank)

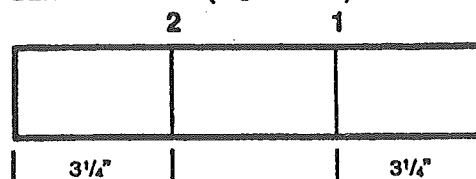

### Setup

Make chalk marks on the blank as shown on the "Bend Sequence."

*(continued on next page)*

## Example: Bending Letters for Signs (continued)

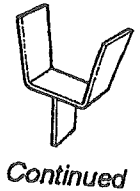

### Bend No. 1

Insert the blank into the Bender to the #1 chalk mark (as in A), and bend it to 80°. Recheck the angle.

### Bend No. 2

Slide the stock to the #2 chalk mark (as in B), and bend it to 80°. Recheck the angle.

To remove the part, pull the pin from the sharp-angle-bend attachment.

### Finishing

Grind and sand all sharp corners.

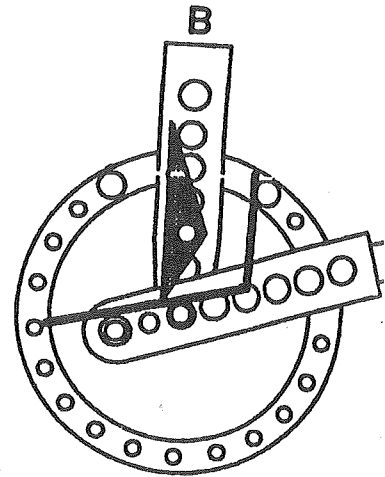
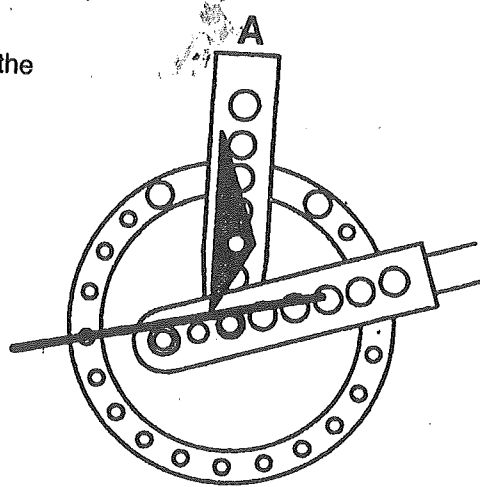

### STOCK REQUIRED

$\frac{3}{16}$ -in. stock; 2-in. max. width

Two 13½-in. blank

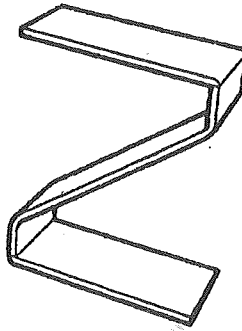

### BEND SEQUENCE (7½-in. blank)

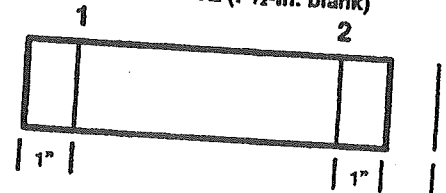

### Setup

Make chalk marks on the 7½-in. blank as shown on the "Bend Sequence."

### Bend No. 1

Insert the blank into the Bender to the #1 chalk mark (as in A), and bend it to 50°. Recheck the angle.

### Bend No. 2

Reverse the part end-for-end. Slide it to the #2 chalk mark (as in B), and bend it to 50°.

### Finishing

Tack-weld the bent piece to the two 4½-in. pieces. The legs of the "Z" should be parallel, 6 in. apart.

Grind and sand all sharp corners.

