

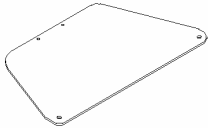

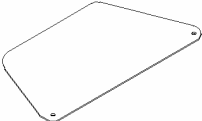

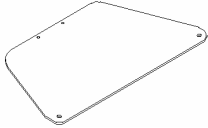







Assembly Instructions

Model TVM-021

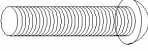
Components List

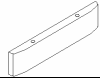
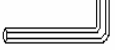
Part Name	Part Details			Qty
	Description	Specification	Figure	
T Glass	Glass for top shelf	Size:800*460mm Thickness:10mm		1
M Glass	Glass for Middle shelf	Size:800*435mm Thickness:6mm		1
B Glass	Glass for Bottom shelf	Size:800*450mm Thickness:6mm		1
TB	Tube	Length:202mm;Diameter:50mm		4
F-T	Foot Tube	Length:60mm;Diameter:50mm		2
CC-L	Chrome Cap(Large)	Diameter:50mm;Thickness:8mm		2
CC-S	Chrome Cap(Small)	Diameter:28mm;Thickness:8mm		2
I B-1	I bolt(NO.1)	Length:45mm;Diameter:10mm		2
I B-2	I bolt(NO.2)	Length:50mm;Diameter:10mm		4
I B-3	I bolt(NO.3)	Length:45mm;Diameter:6mm		2
IB-4	I bolt(NO.4)	Length:mm;Diameter:mm		2
T E S	Tube end seal	Diameter:50mm;Thickness:2mm		10
CT	Cable tidy	Size;;Thickness:		1
F-WS	Foot (Wood Support)	Size;;Thickness:		1
TOOL-1	5# Tool (Screw IB-1 and IB-2)			1
TOOL-2	3# Tool (Screw IB-3)			1

Model TVM-021

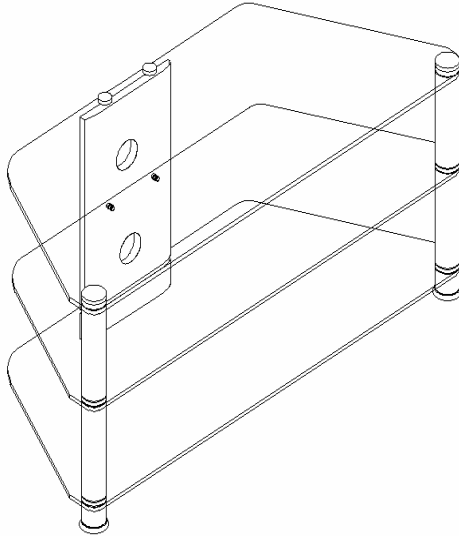

Stage 1

Please not stand is best assembled from bottom up.

- 1.1 Place foot bolts (IB-4) through bottom shelf (B Glass) and the holes at the bottom of the cable tidy. Then screw the foot bolts into the cable tidy nuts until tight.
- 1.2 Screw in the I bolts (IB-2) to top of each foot tube (FT).
- 1.3 Place I bolts (IB-2) in the foot tubes through bottom shelf. Then screw tubes (TB) onto each exposed bolt until tight.
- 1.4 Screw in I bolts (IB-2) to the top of each tube.
- 1.5 Place middle shelf (M Glass) in position over each tube leg with I bolts passing through holes in each corner of the shelf and resting on support pegs located on cable tidy.

Stage 2

- 2.1 Screw tubes (TB) onto I bolts until tight
- 2.2 Screw in I bolts (IB-1) to top of tubes.
- 2.3 Place top shelf (T Glass) over I bolts resting on tubes.
- 2.4 Secure top glass with chrome caps.

