

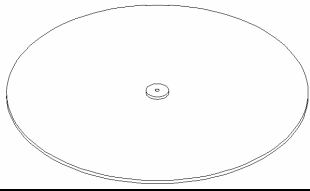

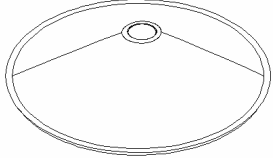



Assembly Instructions

Model CT-030

Components List

Part Name	Part Details			Qty
	Description	Specification	Figure	
T Glass	Top Glass	Size:600 DIA Thickness:6mm		1
IP	Iron Plate			1
TB	Tube			1
CC	Chrome Cap	Diameter:60mm Thickness:8mm		1
IB-1	I bolt(NO.1)	Length:25mm Diameter:10mm		1
IB-2	I bolt(NO.2)	Length:50mm Diameter:10mm		1
T E S	Tube end seal	Diameter:60mm Thickness:2mm		1
TOOL	5# Tool			1

Model CT-030

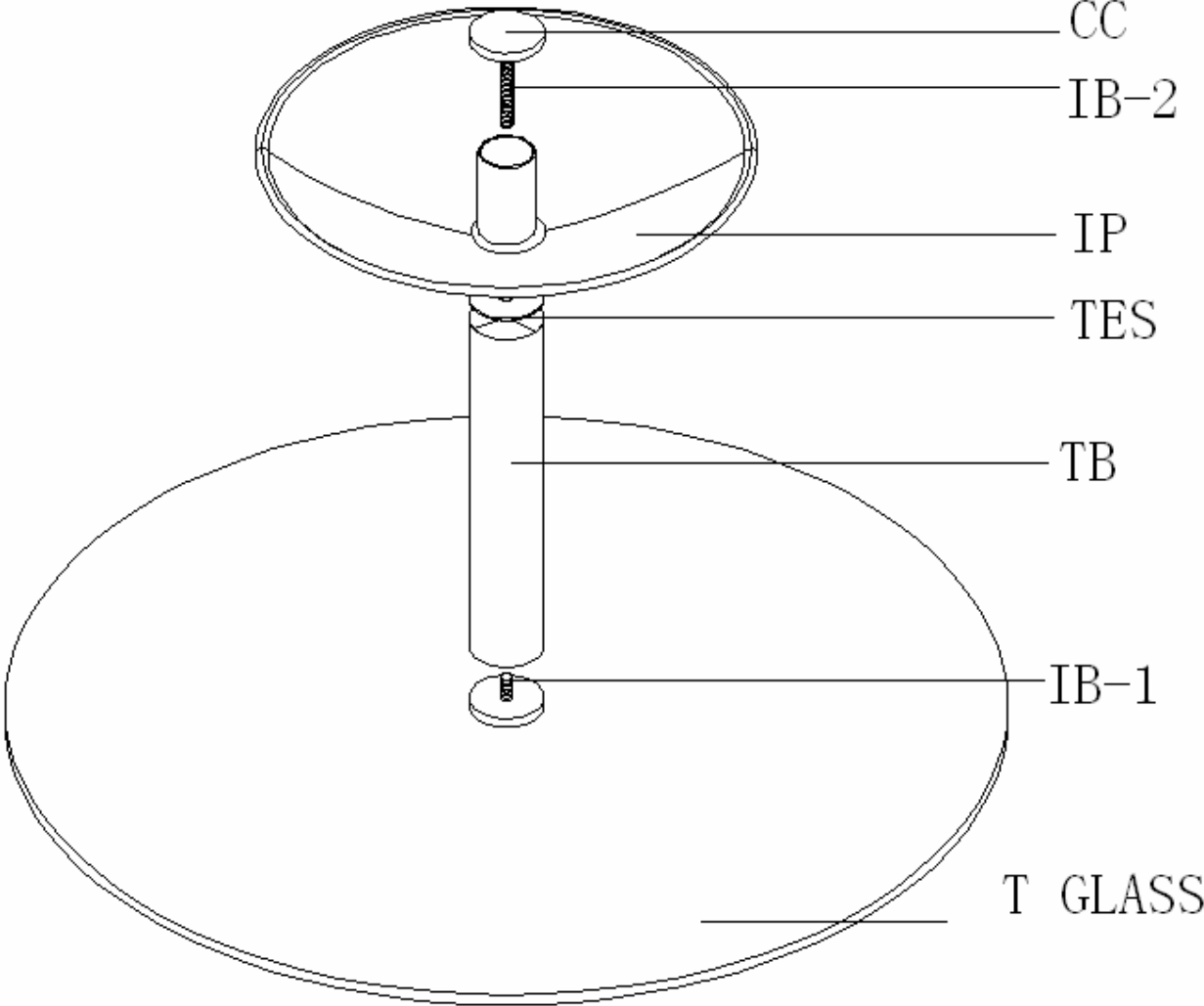

Model CT-030

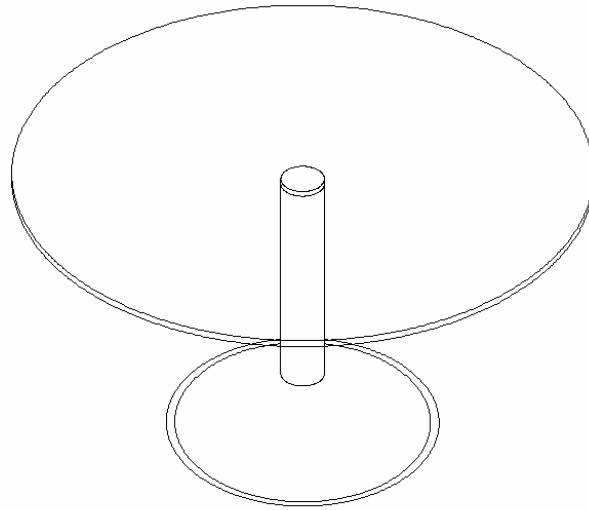

Stage 1

Please note stand is best assembled from the bottom up.

- 1.1 Screw in I bolt (IB-1) to the hole of Chrome Cap on Top Glass.
- 1.2 Screw Tube onto I bolt until tight.

Stage 2

- 2.1 Place Iron Plate resting onto Tube. Then screw in I bolt (IB-2) to the hole of Chrome Cap.
- 2.2 Screw Chrome Cap to fix the Iron Plate.

