

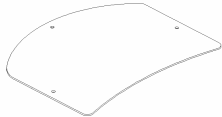









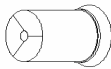

Model CT-010

Components List

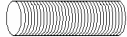
Part Name	Part Details			Qty
	Description	Specification	Figure	
Glass-1	Glass for top and bottom shelves (NO.1)	Size:820*450mm Thickness:8mm		2
Glass-2	Glass for middle shelf (NO.2)	Size:820*650mm Thickness:8mm		1
Glass-3	Glass(NO.3)	Size:500*450mm Thickness:8mm		1
T-1	Foot tube(NO.1)	Length:626mm Diameter:50mm		1
T-2	Tube(NO.2)	Length:148mm Diameter:50mm		3
T-3	Tube(NO.3)	Length:376mm Diameter:50mm		2
T-4	Tube(NO.4)	Length:238mm Diameter:50mm		2
T-5	Tube(NO.5)	Length:84mm Diameter:50mm		3
CC	Chrome Cap	Diameter:50mm Thickness:8mm		3
I B-1	I bolt (NO.1)	Length:35mm Diameter:10mm		3
I B-2	I bolt (NO.2)	Length:50mm Diameter:10mm		8
T E S	Tube send seal	Diameter:50mm Thickness:2mm		19
TOOL-1	5# Tool (screw I B-1 and I B-2)			1

Assembly Instructions

Model CT-010

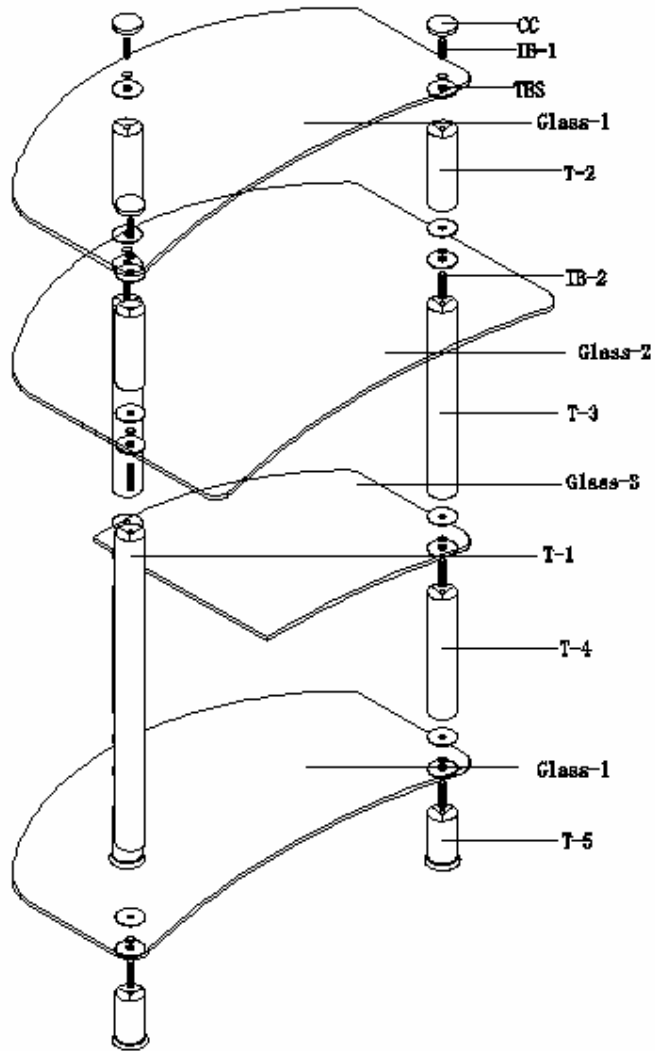

Model CT-010

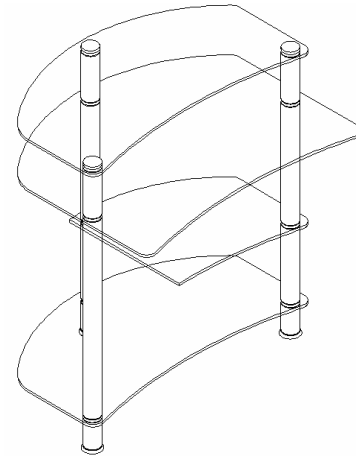

Stage 1

Please note stand is best assembled from the bottom up.

- 1.1 Screw in I bolts (I B-2) to the top of each foot tube (T-5).
- 1.2 Place bottom shelf (Glass-1) in position over each foot tube leg with I bolts passing through holes in each corner of the shelf. Then screw tubes (T-1 and T-4) onto each exposed bolt until tight.
- 1.3 Screw in I bolts (I B-2) to the top of each tube (T-4).

Stage 2

- 2.1 Place NO.3 Glass (Glass-3) in position over each tube leg (T-4) with I bolts passing through holes in each corner of the shelf. Then screw tubes (T-3) onto I bolts until tight.

Stage 3

- 3.1 Screw in I bolts (IB-2) to the top of each tube (T-1 and T-3).
- 3.2 Place Middle shelf (Glass-2) in position over each tube leg with I bolts passing through holes in each corner of the shelf. Then screw tubes (T-2) onto I bolts until tight.

Stage 4

- 4.1 Screw in I bolts (IB-1) to the top of each tube (T-2).
- 4.2 Place top shelf (Glass-1) in position over each tube leg with I bolts passing through holes in each corner of the shelf. Then screw chrome caps to I bolts until tight.

