

DO NOT RETURN PRODUCT TO THE STORE
 Individual stores do not stock parts.

NO REGRESAS ESTA PRODUCTO A LA TIENDA
 Las tiendas no tiene partes.

NE RETOURNEZ PAS LE PRODUIT AU MAGASIN
 Les magasins individuels ne gardent pas de pièces.

If a part is missing or damaged, please visit our website or call our toll-free customer service line. We will gladly ship your replacement parts FREE of charge.

Si las partes están perdidas o dañadas Por favor visite nuestra página de Internet o llame a nuestra línea de teléfono gratis de Servicio al Cliente. Nosotros le enviaremos sus repuestos sin cargo adicional, serán totalmente gratis.

Si une pièce est manquante ou endommagée, veuillez visiter notre site web ou appelez sans frais notre Service à la clientèle. Nous expédierons avec plaisir vos pièces de rechange GRATUITEMENT.

Need Parts or Assistance?

Nesacitas partes o Asistencia?

Besoin de Pièces ou d'assistance?

WWW.AMERIWOOD.COM/PARTS

or call toll free:
 o llame a nuestra línea gratis: **1-800-489-3351**
 ou appelez sans frais:

For prompt, reliable service; please have your assembly manual ready.

Para servicio mas rapido y reliable por favor tenga esta manual listo.

Pour un service rapide et fiable, s'il vous plait ayez votre livret d'assemblage en main.

-KEEP FOR REFERENCE-

-GUARDAR PARA REFERENCIA-

-GARDEZ POUR RÉFÉRENCE-

⚠ WARNING



Unit can tip over causing severe injury or death.

- Anchor unit to stud or wall.
- **DO NOT** allow children to climb on unit.
- Put heavy items on lower shelves or drawers.
- Read and follow all assembly instructions.

⚠ ADVERTENCIA

Este mueble puede caerse por encima causando daño serio o la muerte

- Anolar el mueble a un espárrago muro.
- **NO** dejar que los niños suben por encima del mueble.
- Poner los articulos mas pesados en los tableros o cajones inferiores.
- Leer y seguir todos de los instuccionnes para el montaje.

⚠ AVERTISSEMENT

L'unité peut basculer et causer des blessures graves ou la mort.

- Fixez l'unité au mur ou à un montant.
- Ne laissez PAS les enfants grimper sur le meuble
- Déposez les pièces lourdes sur les tablettes ou tiroirs du bas.
- Lire et suivre toutes les instructions d'assemblage.

Thank you for purchasing from AMERIWOOD.
Visit www.ameriwood.com to view the limited warranty valid in the U.S. and Canada.

AMERIWOOD CONSUMER SERVICES

Before starting – Antes de Empezar – Avant de débiter.



- Read each step carefully before starting. It is very important that each step is performed in the correct order. If these steps are not followed in sequence, assembly difficulties will occur.**

Lea con cuidado cada paso antes de empezar. Es muy importante que cada paso se ejecute en el orden correcto, de lo contrario, tendrá dificultades en el ensamblaje.

Lisez chaque étape soigneusement avant de commencer. Il est très important que chaque étape de l'assemblage soit exécutée dans le bon ordre. Si ces étapes ne sont pas suivies dans l'ordre, des difficultés d'assemblage se produiront.

- Make sure all parts are included. Most board parts are labeled or stamped on the raw edge. Asegúrese de tener todas las piezas. Cada pieza está marcada con una etiqueta o con un sello en el lado sin acabado.**

Assurez-vous que toutes les pièces sont incluses. La plupart des pièces en bois sont étiquetées ou estampées sur le bord non-fini.

- Work in spacious area, preferably on a carpet, near the place the unit will be used. Ejecute el ensamblaje en un área espaciosa, de preferencia sobre alfombra y cerca del lugar donde se usará el mueble.**

Travaillez dans un endroit spacieux, préférentiellement sur un tapis, près de l'endroit où le meuble sera utilisé.

- Have the following tools.**

Tenga las siguientes herramientas a la mano. Ayez les outils suivants à la portée de la main.

- Do not use power tools to assemble your furniture. Power tools may strip or damage the parts. No use herramientas eléctricas para ensamblar el mueble. Las herramientas eléctricas pueden dañar la unidad.**

N'utilisez pas d'outils électriques pour assembler votre mobilier. Les outils électriques peuvent démonter ou endommager les pièces.

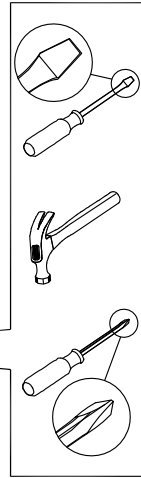

*Gracias por haber comprado de AMERIWOOD.
Visite www.ameriwood.com para ver la garantía limitada válida solamente en Estados Unidos y Canadá.
SERVICIO A LA CLIENTELA DE AMERIWOOD*

**Merci pour votre achat de Ameriwood.
Visitez www.ameriwood.com pour voir la garantie limitée valide au Canada et aux États-Unis.**

SERVICE À LA CLIENTÈLE DE AMERIWOOD

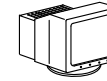

Visit our website:
Visite nuestra página de internet:
Visitez notre site Web:

WWW.AMERIWOOD.COM/PARTS



Call us at:
Llame al: 1-800-489-3351
Téléphonez au:



Fax:
Envíe un facsímil: 1-636-745-1005
Envoyez une télécopie:



Write to: **AMERIWOOD INDUSTRIES**
Escriba a: **410 East First Street South**
Écrivez à l'adresse: **Wright City, MO 63390 USA**
Attention: Consumer Services

9:00am - 5:00pm
Monday – Friday
~~9:00am - 5:00pm~~
Central Time

~~Saturday~~
~~9:00am - 5:00pm~~
~~Central Time~~

Lunes – Viernes
~~9:00am - 5:00pm~~
Tiempo Central

~~Saturday~~
~~9:00am - 5:00pm~~
~~Timeo Central~~

Lundi – Vendredi
~~9:00am - 5:00pm~~
Heure Normale du Centre

~~Samedi~~
~~9:00am - 5:00pm~~
~~Heure Normale du Centre~~

HELPFUL HINTS

- Visit our website for basic assembly tips and to order replacement parts.
- Identify, sort and count the parts before attempting assembly.
- Call our toll free number if you need assistance identifying parts.
- Compression dowels are tapped in with a hammer.
- Slides have lips only on the right side.
- Cam locks that are properly fastened on a horizontal board will face toward the center of the unit, on a vertical board the point on the lock will face the bottom.
- Back panels provide stability and support. Use all the nails provided.
- When nailing back panels to the unit, be sure there is equal distance on all sides to square the unit.
- Units without the back panel installed may collapse.
- Clean the product with your favorite furniture polish and a soft cloth. DO NOT USE harsh chemicals or abrasive cleaners.
- Move your new furniture carefully, with two people lift and carry the unit to a new location.
- Never push, pull or drag your furniture (especially on carpet).
- Your Ameriwood furniture can be disassembled and reassembled to move.
- Additional parts are available for a nominal fee.

NOTAS UTILES

- Visite nuestro pagina de internet para que siga los pasos básicos del samblaje del mueble y ordene las partes que necesitan ser reemplazadas.
- Identifique, clasifique y cuente todas las partes antes de empezar el ensamblaje.
- Llame gratis al número de servicio al cliente si necesita ayuda con el montaje de la unidad.
- Las clavijas de compresión se taladran con un martillo.
- Las correderas del cajón solo tienen un borde en el lado derecho.
- En las piezas (tablas) horizontales, las cerraduras deben quedar al lado derecho cuando están colocadas apropiadamente. En el caso de una pieza (tabla) vertical, las cerraduras deben quedar hacia abajo.
- Los paneles traseros dan estabilidad al mueble. Use todos los clavos incluidos.
- Clave el panel trasero teniendo cuidado de mantener la misma distancia entre los clavos.
- Los muebles que no tienen el panel trasero pueden colapsar.
- Use cualquier producto que sea específico para limpiar muebles. No use químicos o sustancias abrasivas.
- Mueva su mueble con mucho cuidado y con la ayuda de otra persona levante y mueva el mueble a su lugar.
- Nunca empuje, jale o arrastre un mueble (especialmente sobre alfombra).
- Los muebles de Ameriwood pueden ser ensamblados o desarmados para ser transportados.
- Por un pago nominal puede ordenar partes adicionales.

NOTES UTILES

- Visitez notre site web pour obtenir des conseils de montage de base et pour commander des pièces de rechange.
- Identifiez, séparez et comptez les pièces avant d'entreprendre l'assemblage.
- Appelez à notre numéro sans frais si vous avez besoin d'aide pour identifier les pièces.
- Les goujons de compression sont insérés avec un marteau.
- Les glissières ont des rebords seulement sur le côté droit.
- Les serrures de came qui sont serrées sur une planche horizontale doivent faire face au centre de l'unité. Sur une planche verticale, la pointe de la serrure doit être orientée vers le bas.
- Les panneaux arrière stabilisent et soutiennent le meuble. Utilisez tous les clous fournis.
- En enfonçant les clous dans une planche, assurez-vous que toutes les distances entre les coins sont égales pour que l'unité soit carrée.
- Sans leur panneau arrière, les unités peuvent s'écrouler.
- Nettoyez le produit avec votre poli à meubles préféré et un linge doux. NE PAS UTILISER de produits chimiques ou de nettoyeurs abrasifs.
- Déplacez votre nouveau meuble avec soin, avec l'aide d'une autre personne et portez-le jusqu'à son nouvel emplacement.
- Ne jamais pousser ou traîner votre meuble (surtout sur un tapis).
- Votre meuble Ameriwood peut être démonté puis ré-assemblé pour être déplacé.
- Il est possible d'obtenir des pièces supplémentaires à un prix modique.

PARTS - PIEZAS - PIECES

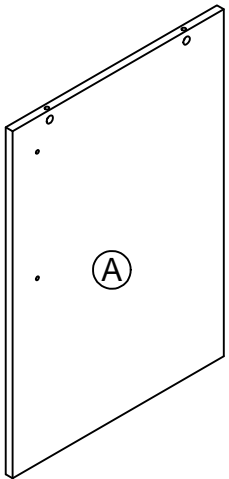

left panel
panel izquierdo
panneau gauche
39354026010

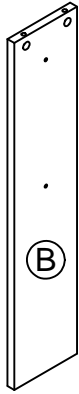

left rear panel
panneau
izquierdo de
atrás
panneau
arrièregauche
39354026020

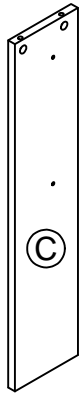

right rear panel
panneau derecho
de atrás
panneau arrière
droit
39354026030

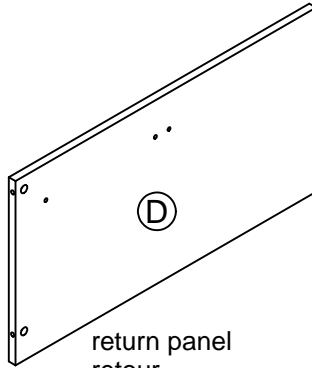

return panel
retour
panel de
retorno
39354026040

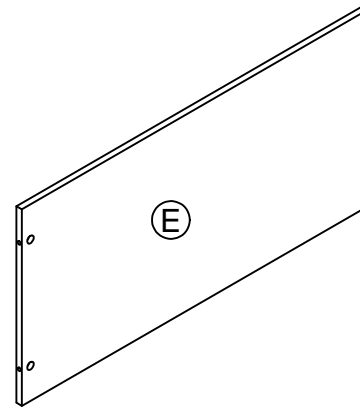

modesty panel
panel de modestia
panneau de modestie
39354026050

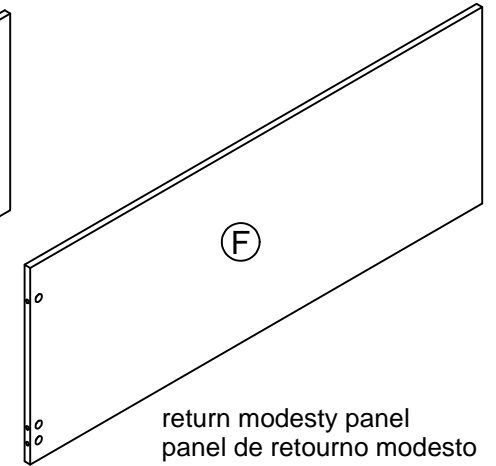

return modesty panel
panel de retorno modesto
panneau de modestie retour
39354026060

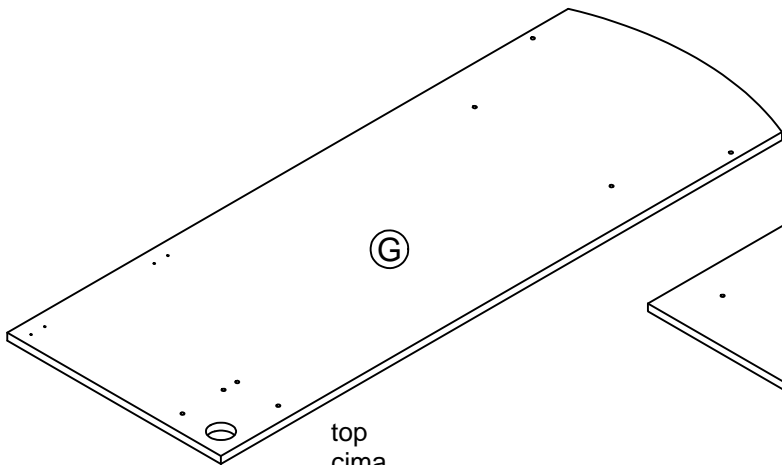

top
cima
dessus
39354026070

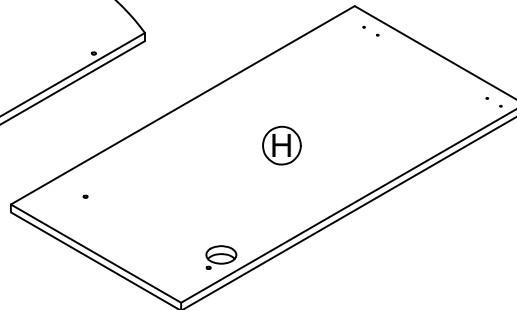

return top
cima del retorno
dessus du retour
39354026080

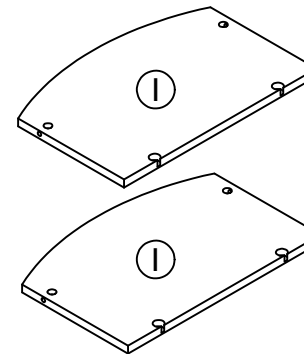

fixed shelf
estante fijo
étagère fixe
39354026090

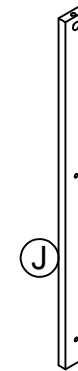

left rail
barra izquierda
guide gauche
39354026100



right rail
barra derecha
guide droit
39354026110

PARTS - PIEZAS - PIECES

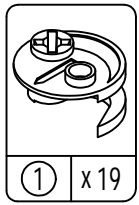

① x 19
#A22500
cam lock
cerradura de leva
serrure de came

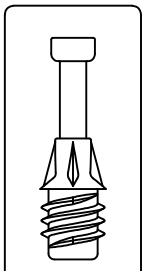

② x 19
#A22510
cam bolt
perno de leva
boulon de came

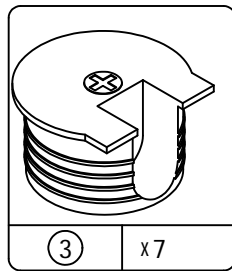

③ x 7
#A22820
connector
conectar
connecteur

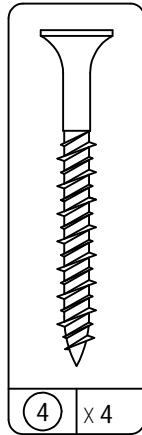

④ x 4
#A13410
1 3/4" flat head
cabeza plano 1 3/4"
tête plate 1 3/4"

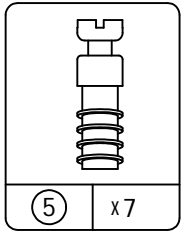

⑤ x 7
#A22810
connector bolt
perno del
conector
boulon connecteur

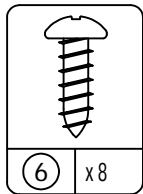

⑥ x 8
#A12210
1/2" pan head
cabeza redondo 1/2"
tête ronde

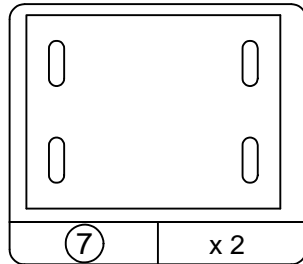

#A54270
connecting plate
placa de
conexión
plaque de
reccordement

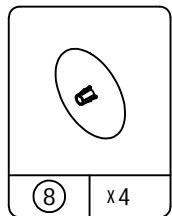

⑧ x 4
#A24045
screw head cap
casquillo cabeza
de tornillo
cache-vis

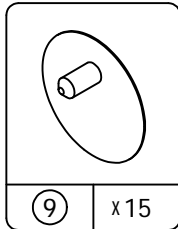

⑨ x 15
#A243026
cam cover
tapa de leva
l'abri de came

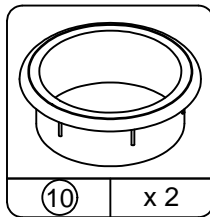

#A70040
grommet
ojal
rondelle

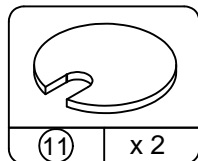

#A70050
grommet cover
tapa
couvre-rondelle

This illustration shows how the CAM fastening system works.
Esta ilustración muestra el sistema de fijación de leva y como funciona.
Cette illustration montre le système de fixation CAME et son fonctionnement.

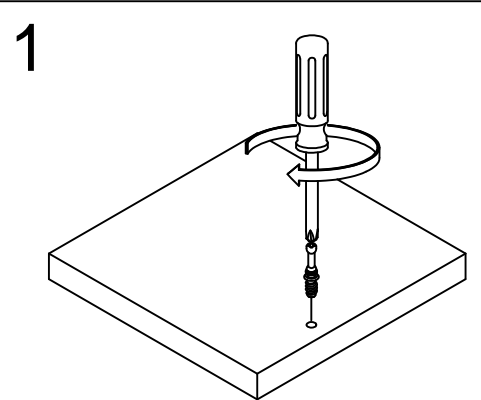

1
Tighten to fully seat. Do not over tighten.
Apriétese a totalmente asiento. No haga encima de apriétese.
Serrez pour mettre le siège bien en place. Ne pas trop serrer.

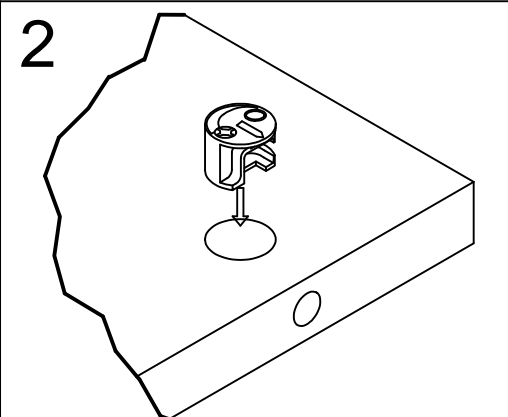

2
Proper orientation of cam.
La orientación apropiada de leva.
Bonne orientation de la came.

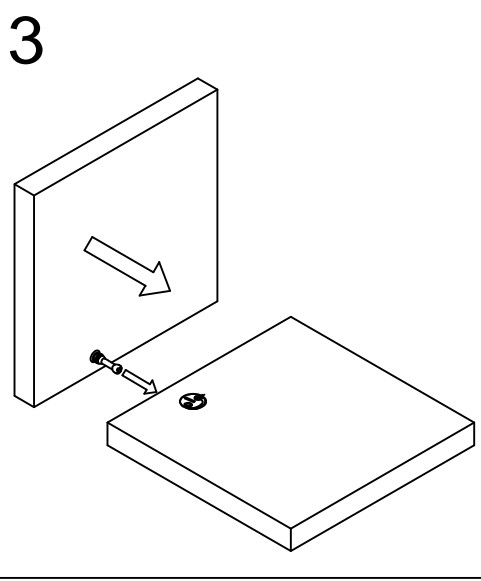

3
Lock
Apretar
Serrer

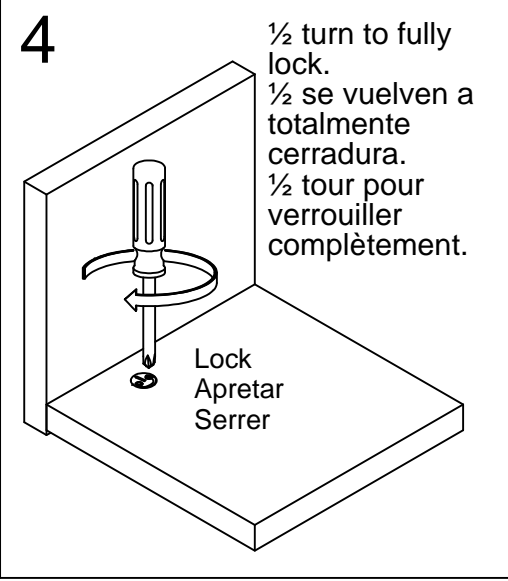

4
1/2 turn to fully lock.
1/2 se vuelven a totalmente cerradura.
1/2 tour pour verrouiller complètement.

1

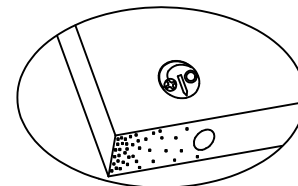
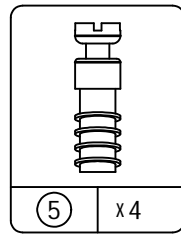
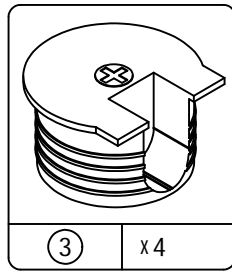
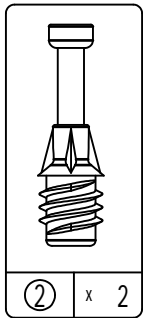
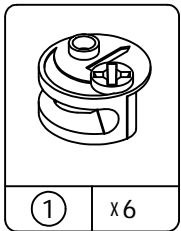
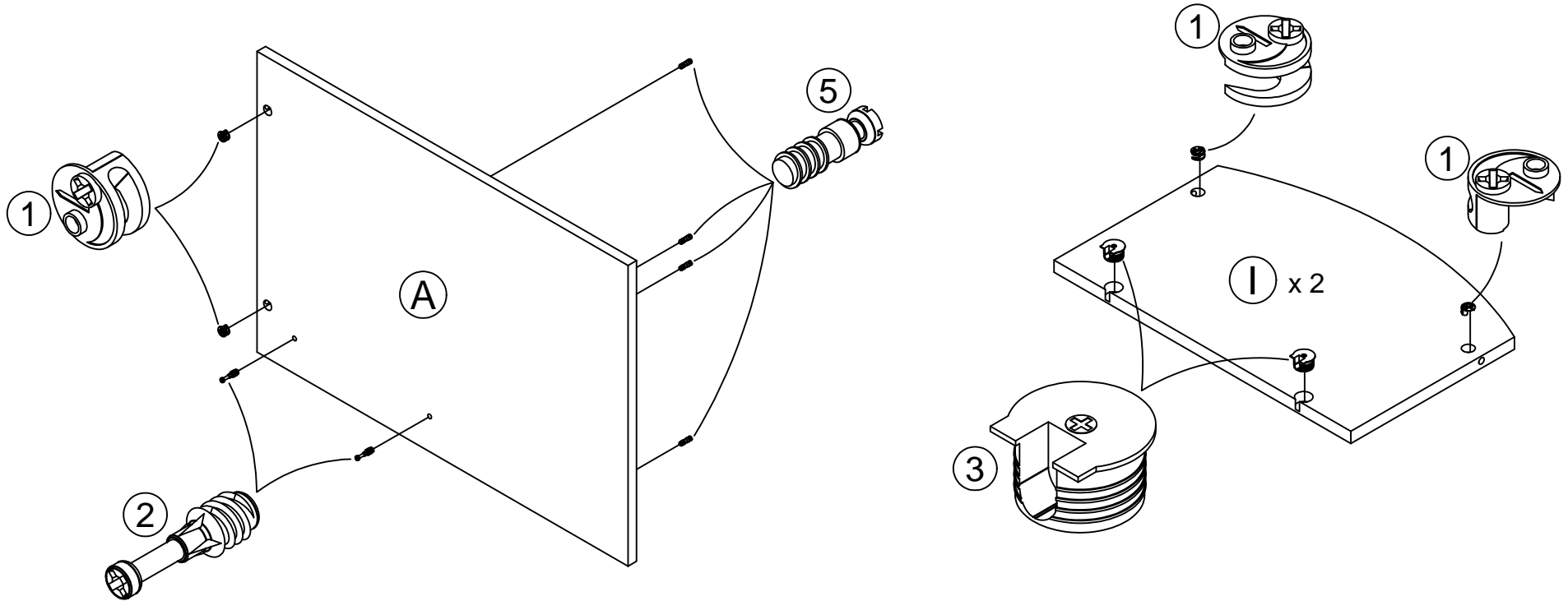

Proper orientation of CAM LOCK
Posición correcta de la cerradura de leva.
Bonne orientation de la SERRURE DE CAME

2

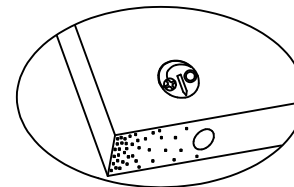
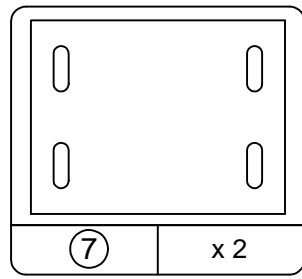
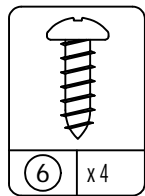
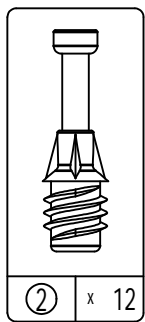
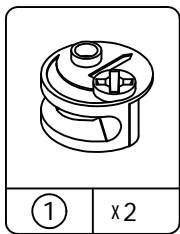
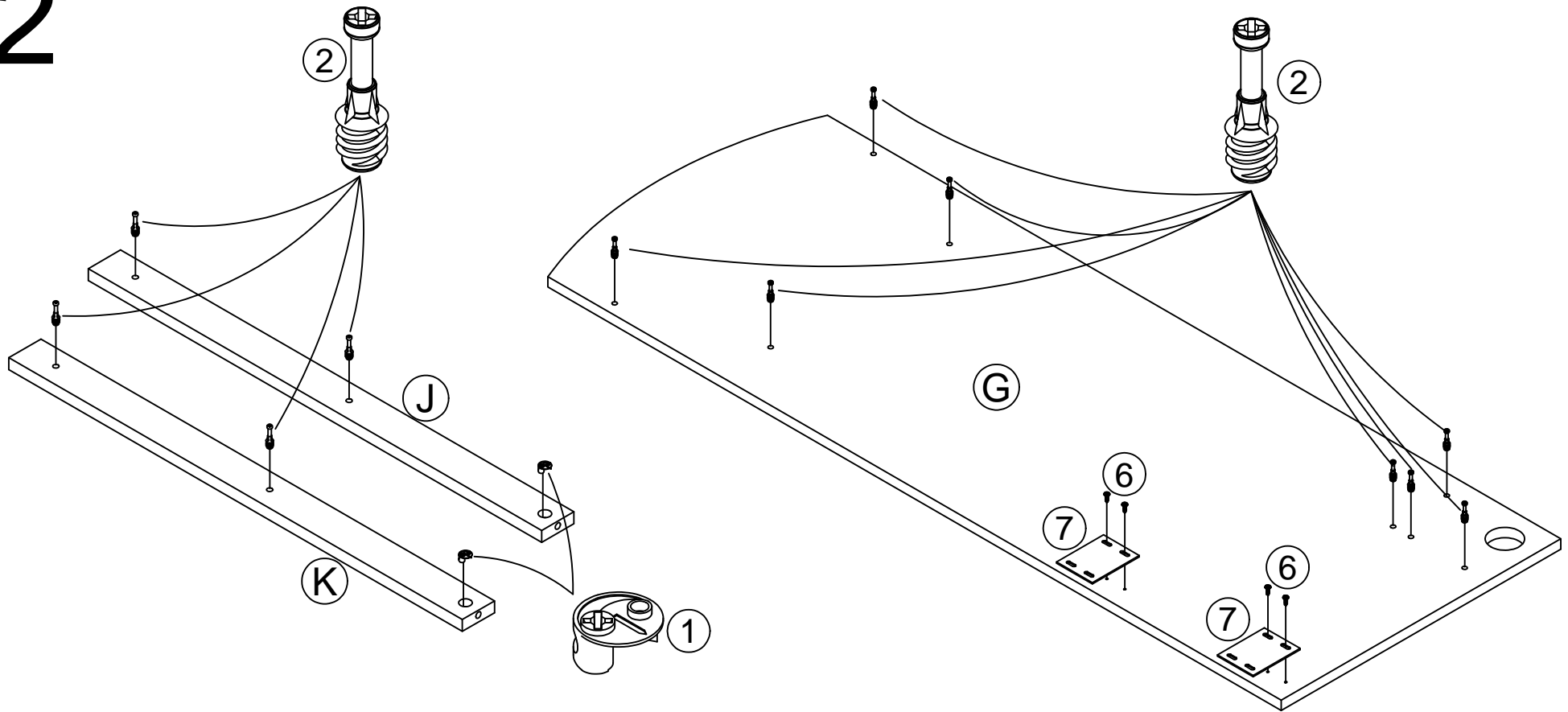

Proper orientation of CAM LOCK
Posición correcta de la cerradura de leva.
Bonne orientation de la SERRURE DE CAME

3

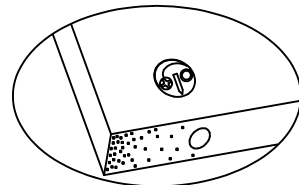
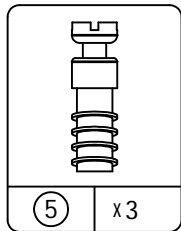
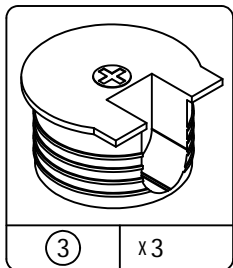
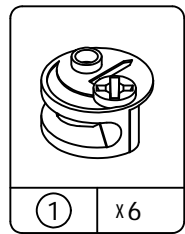
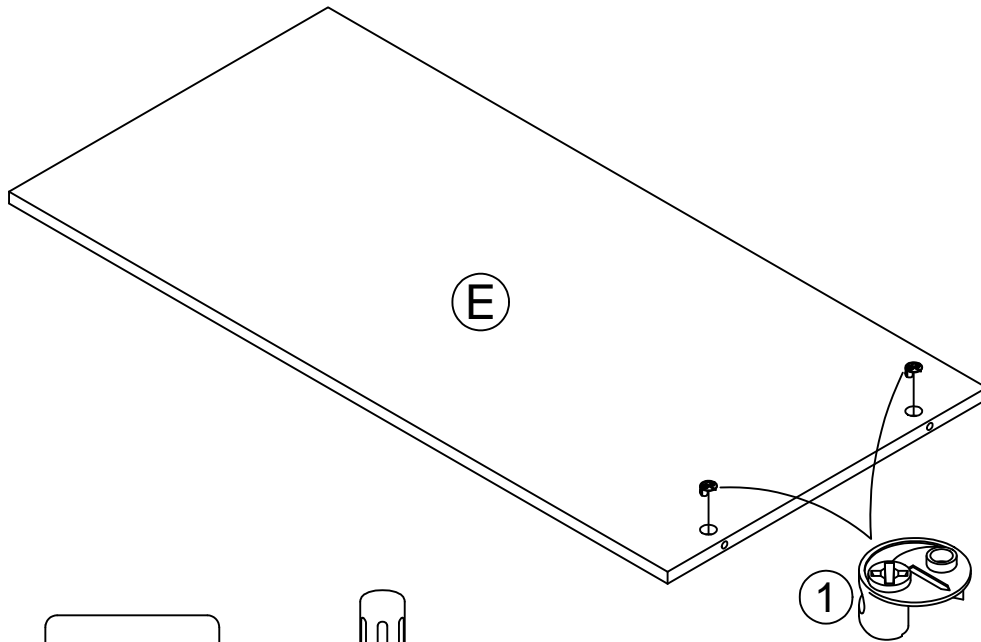

Proper orientation of CAM LOCK
Posición correcta de la cerradura de leva.
Bonne orientation de la SERRURE DE CAME

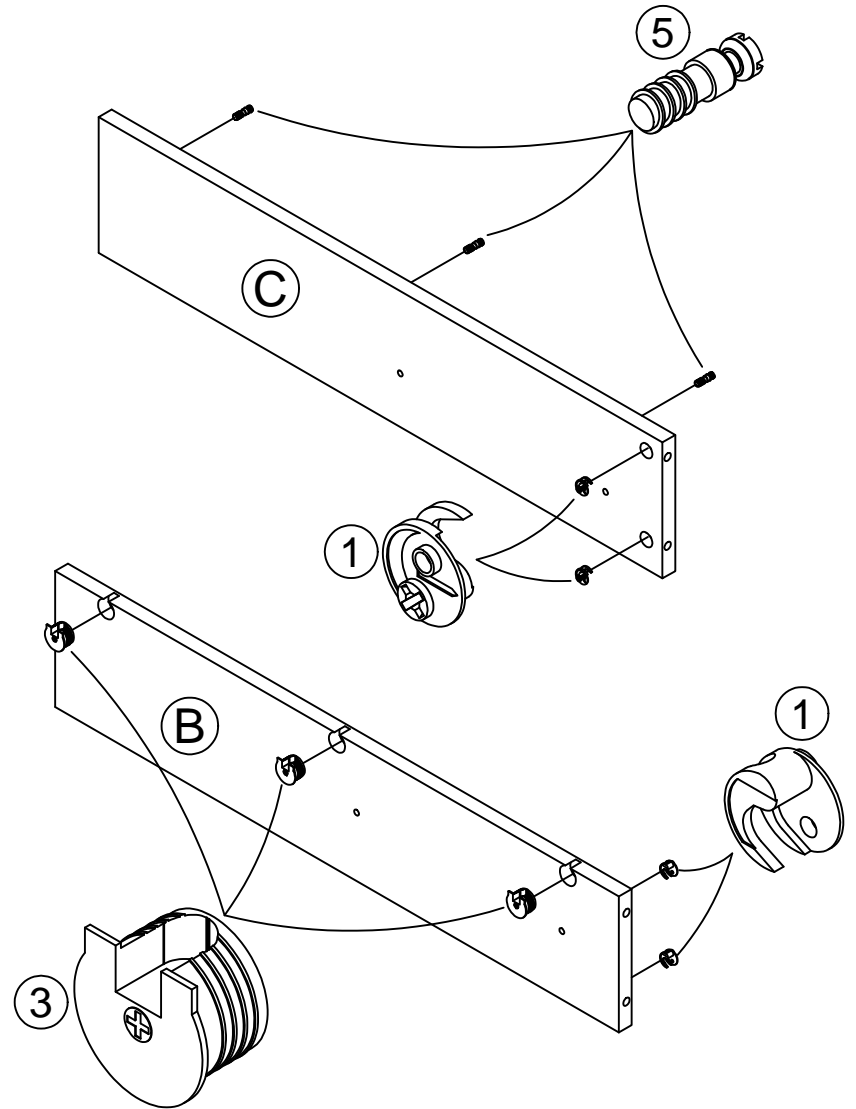

4

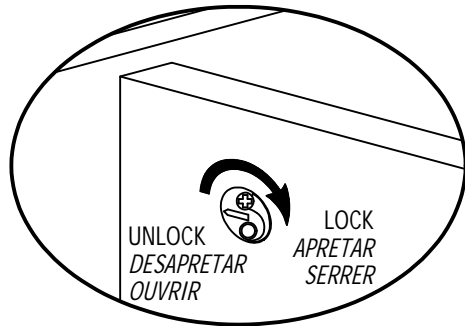
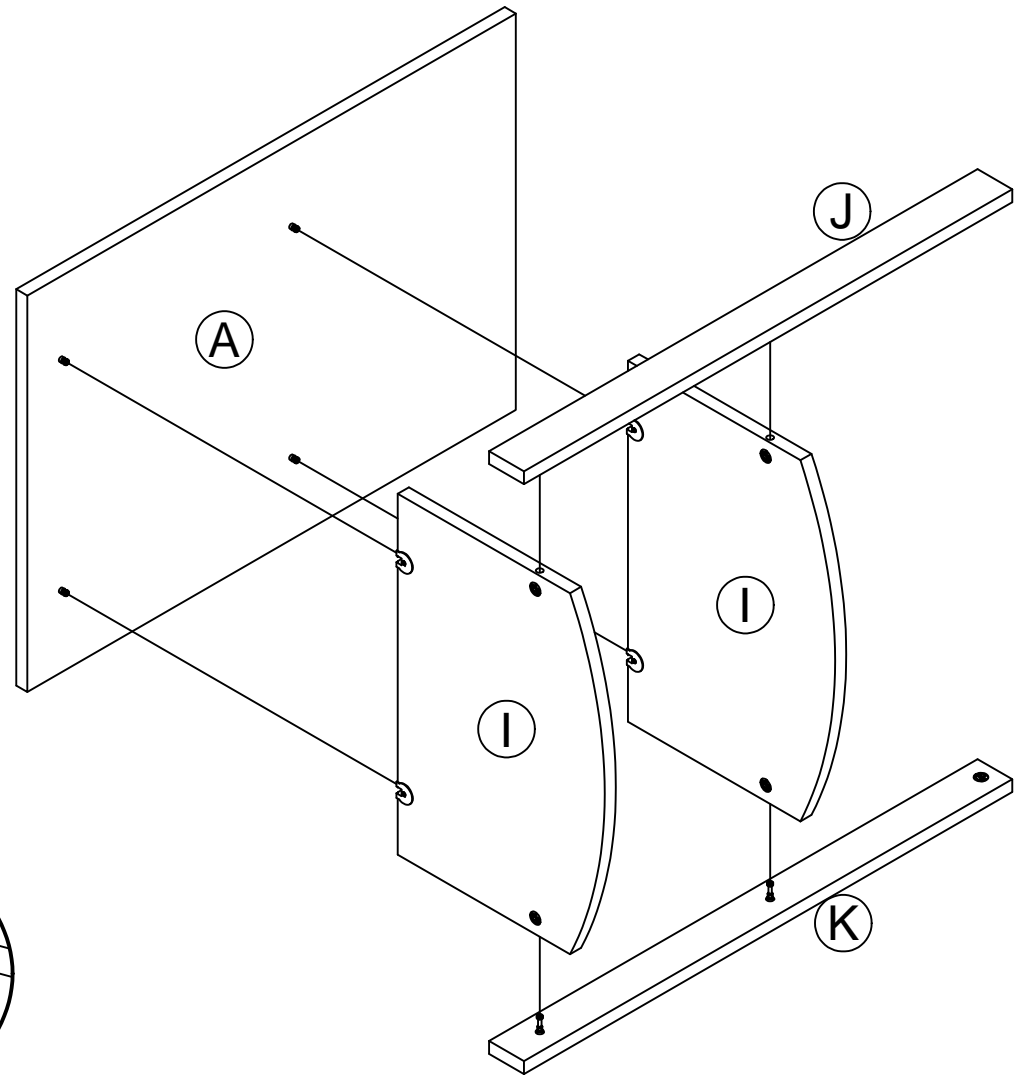
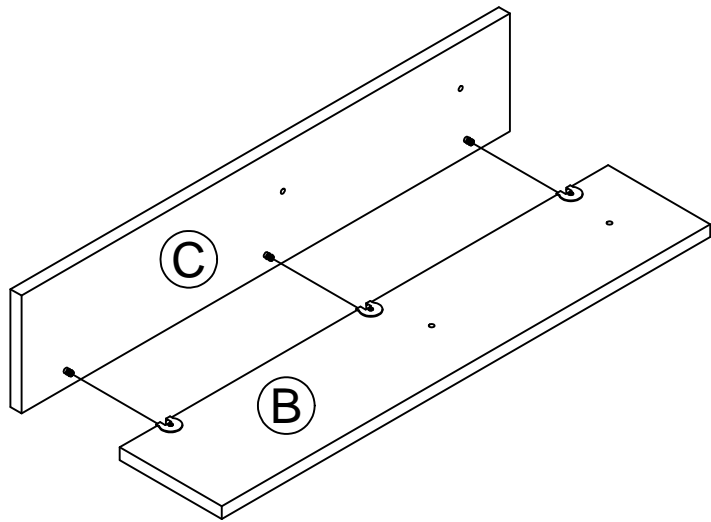

5

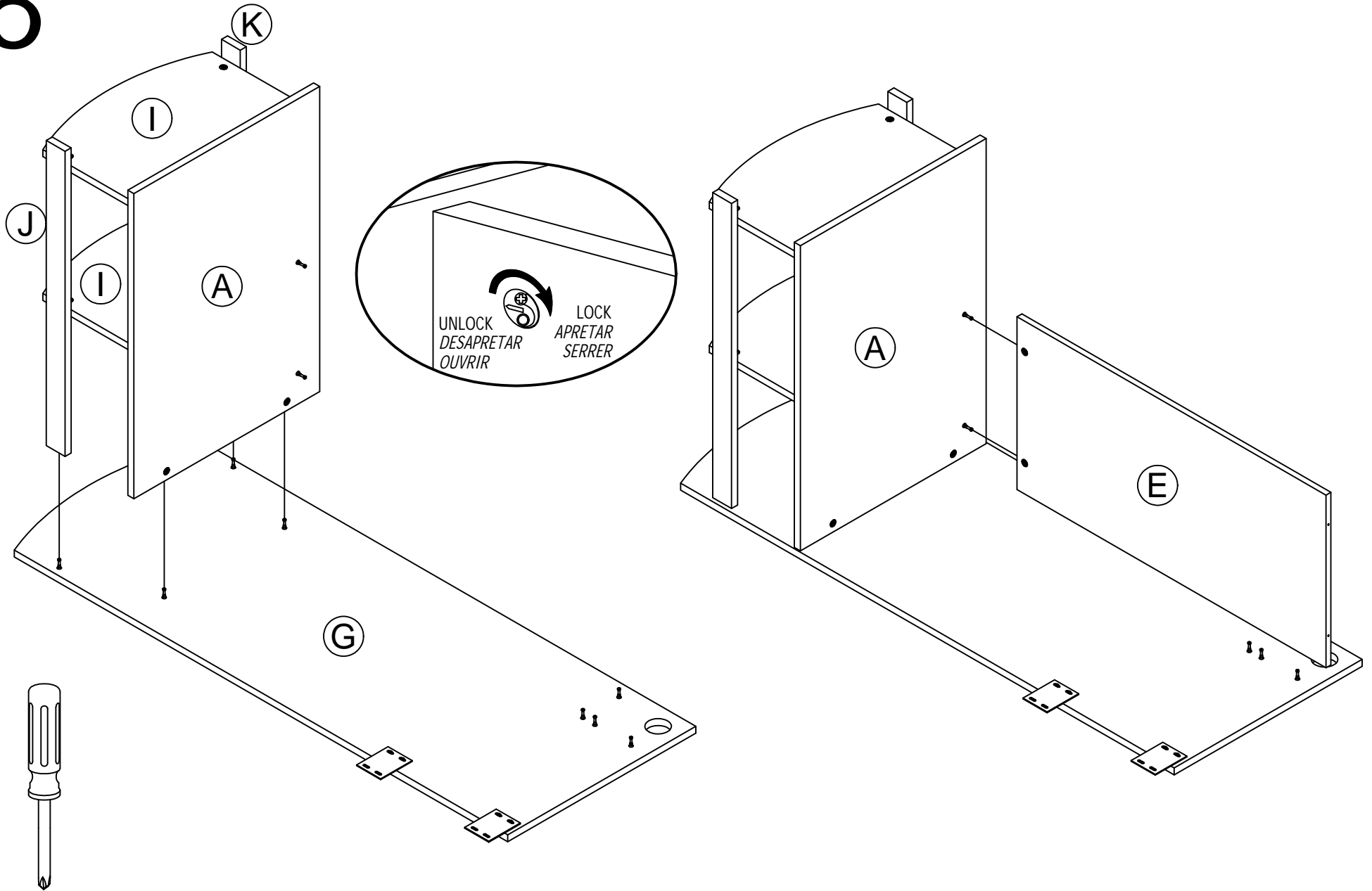

6

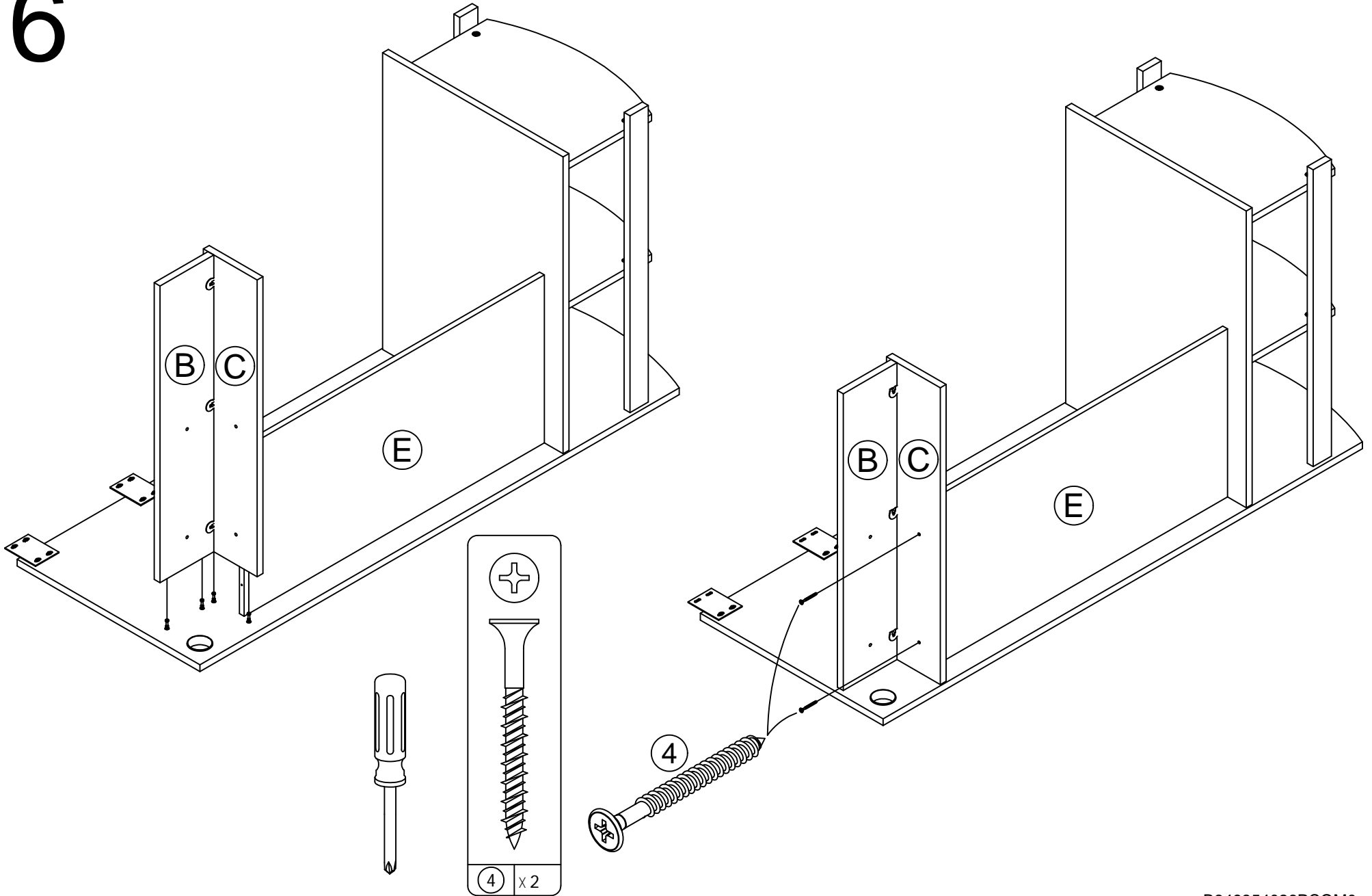

7

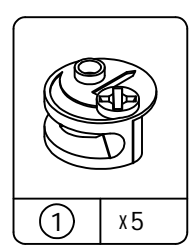
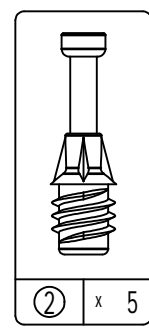
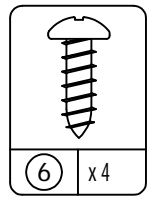
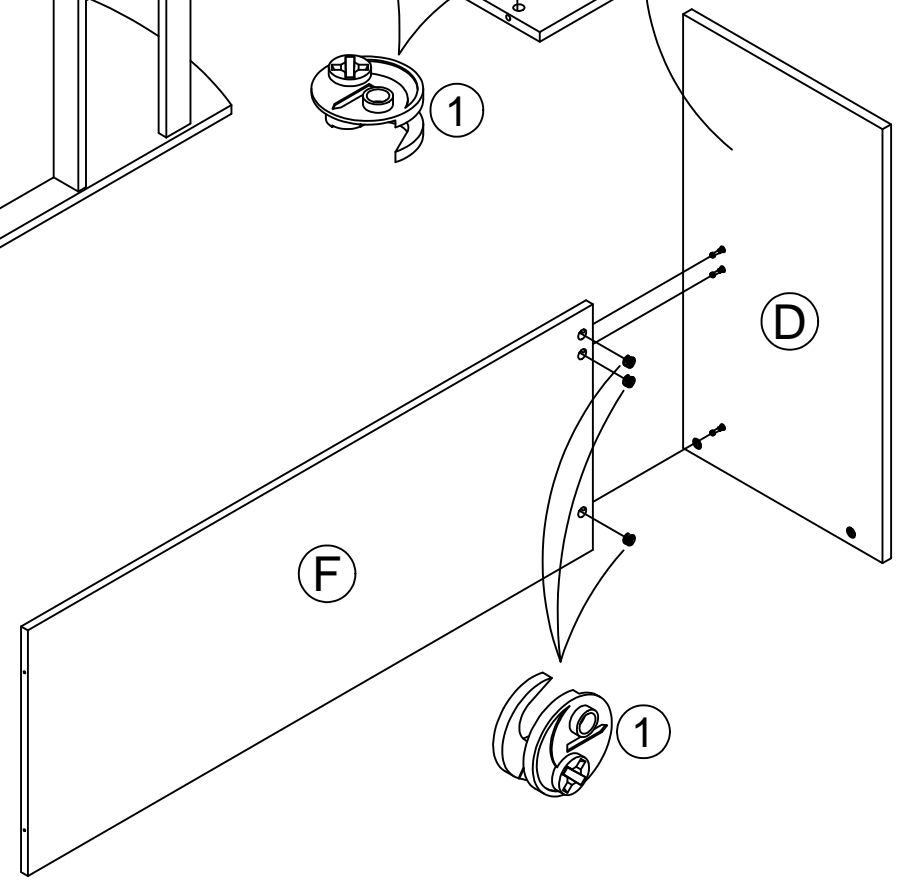
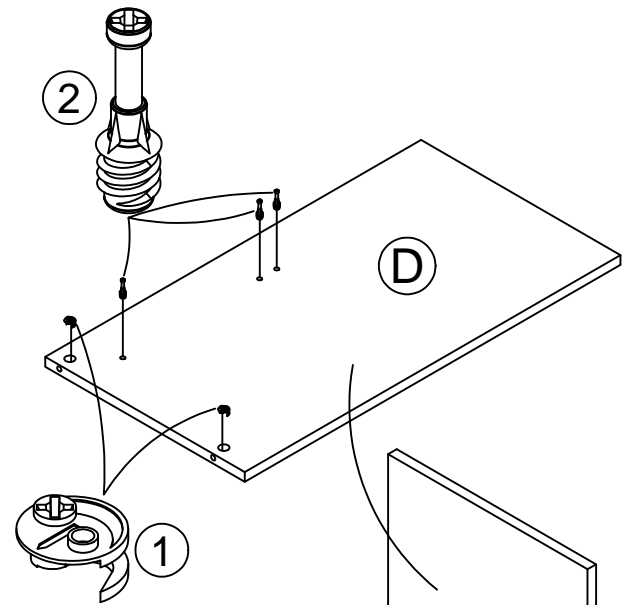
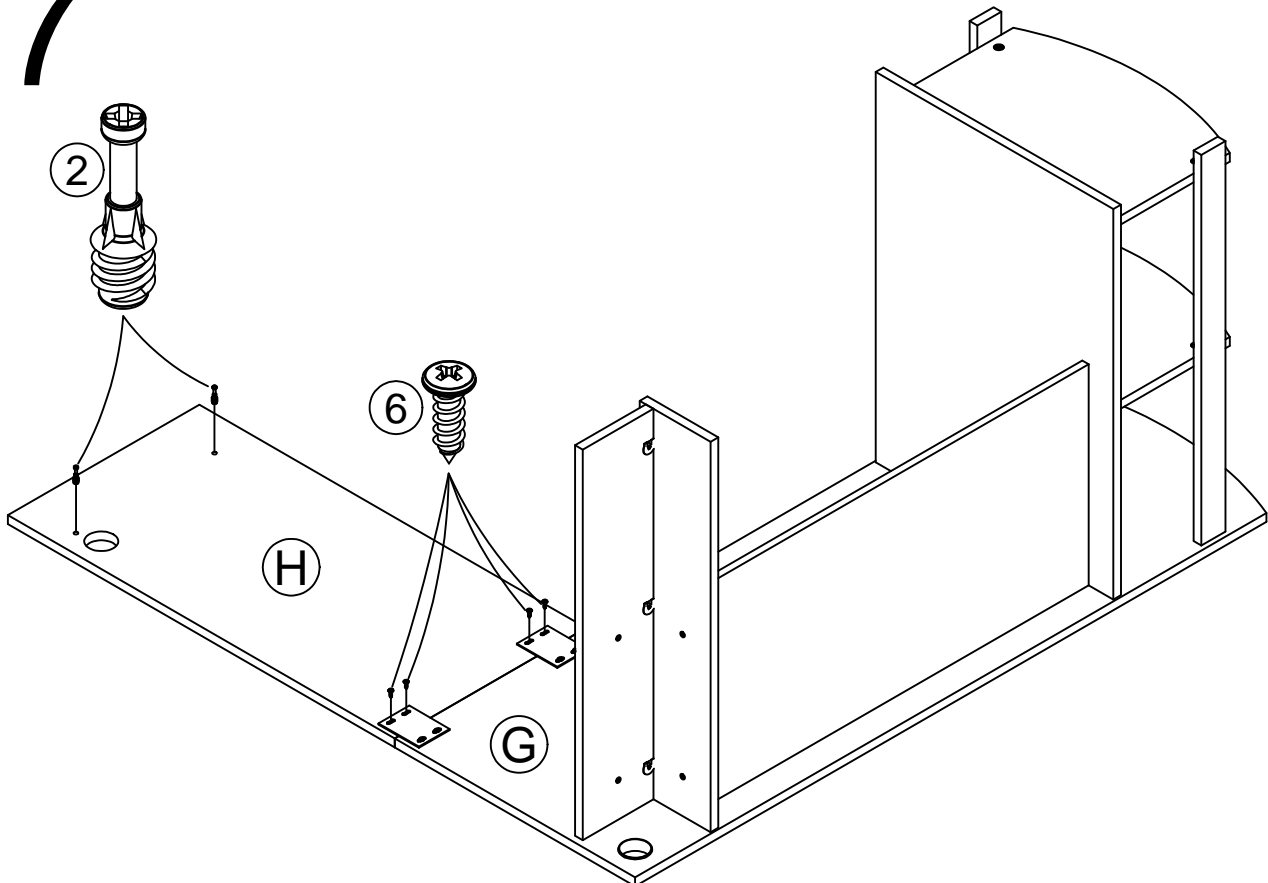

8

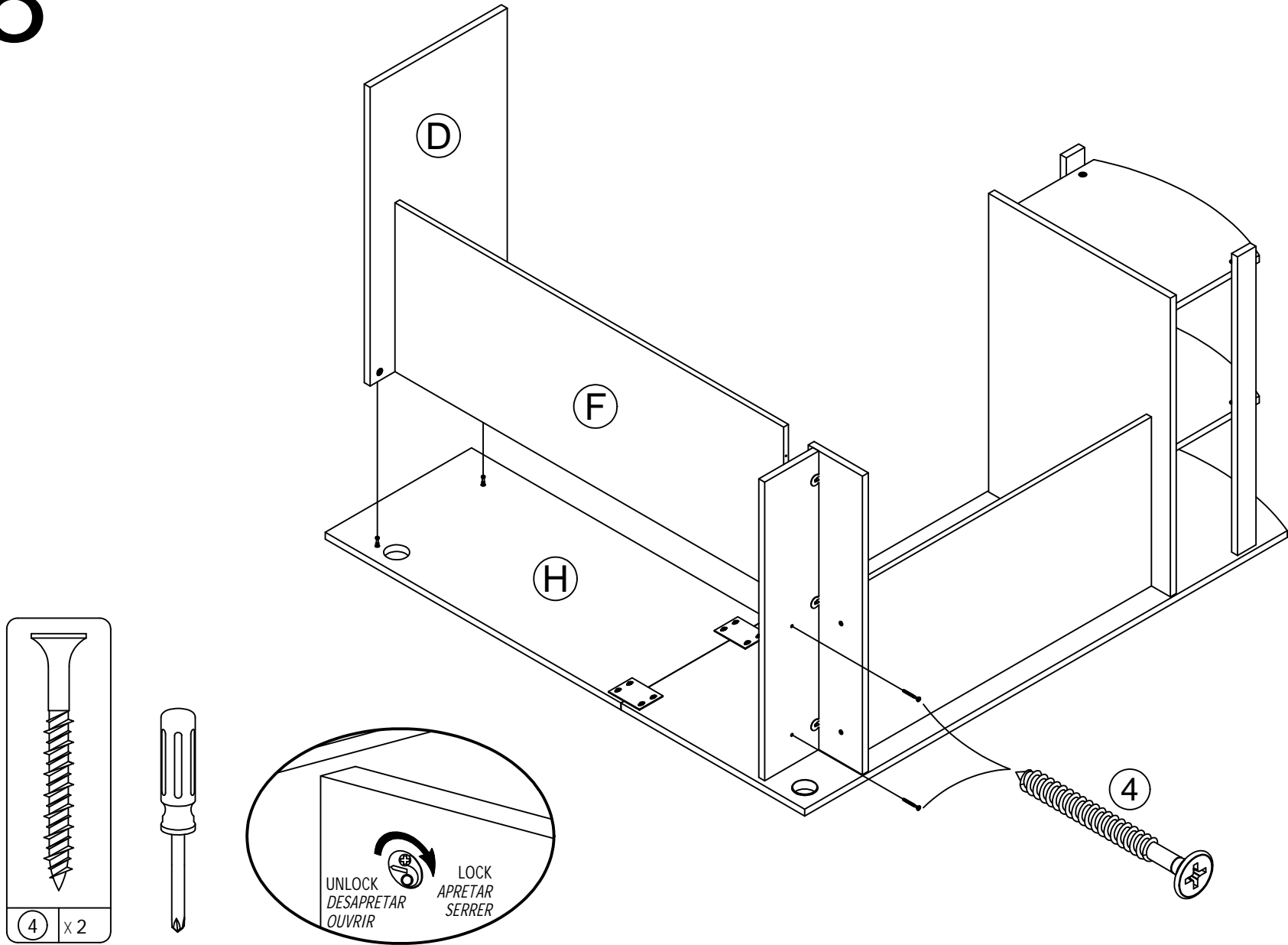

9

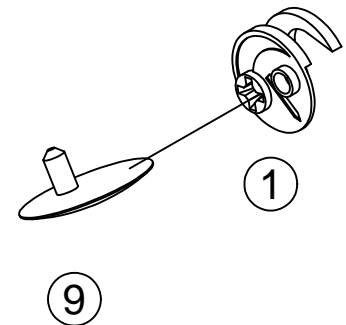
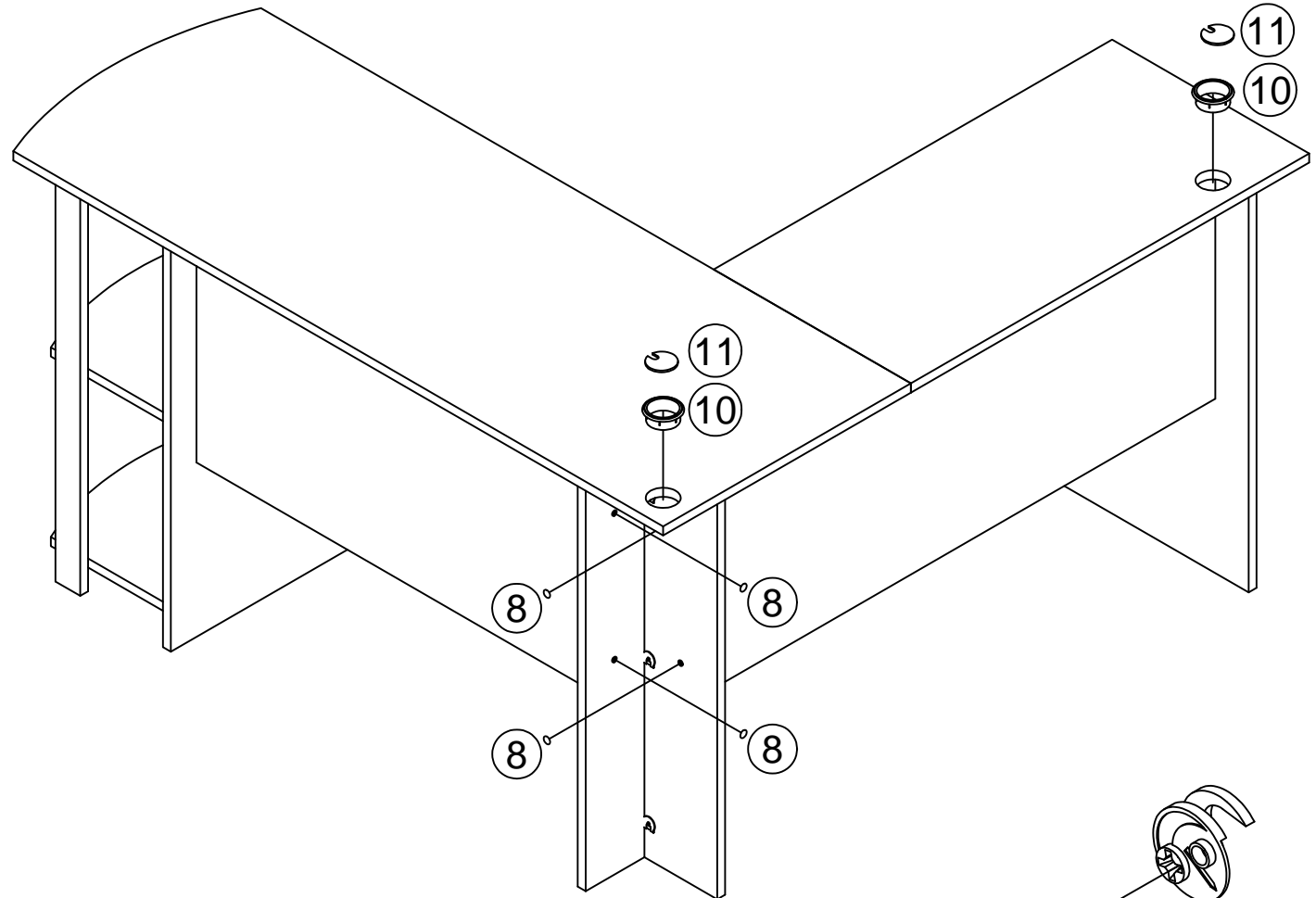
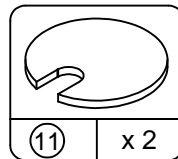
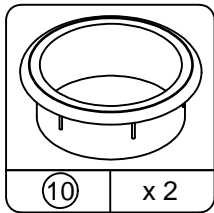
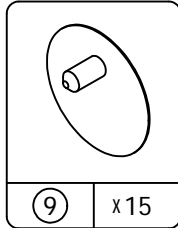
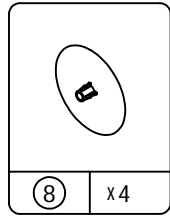

With assistance of another person, carefully lift and turn the unit upright.
Con la ayuda de otra persona, cuidadosamente levante y voltee el mueble hacia arriba.
Avec l'aide d'une autre personne, soulevez délicatement et tournez l'unité à l'endroit.

Press the cam covers (9) onto the cam locks (1).
Prensa que cubre la cam (9) en las cerraduras (1).
Appuyez sur les couvertures de cam (9) sur les écluses de la cam (1).

10

MAXIMUM LOADS – CARGA MAXIMA - CHARGES MAXIMALES

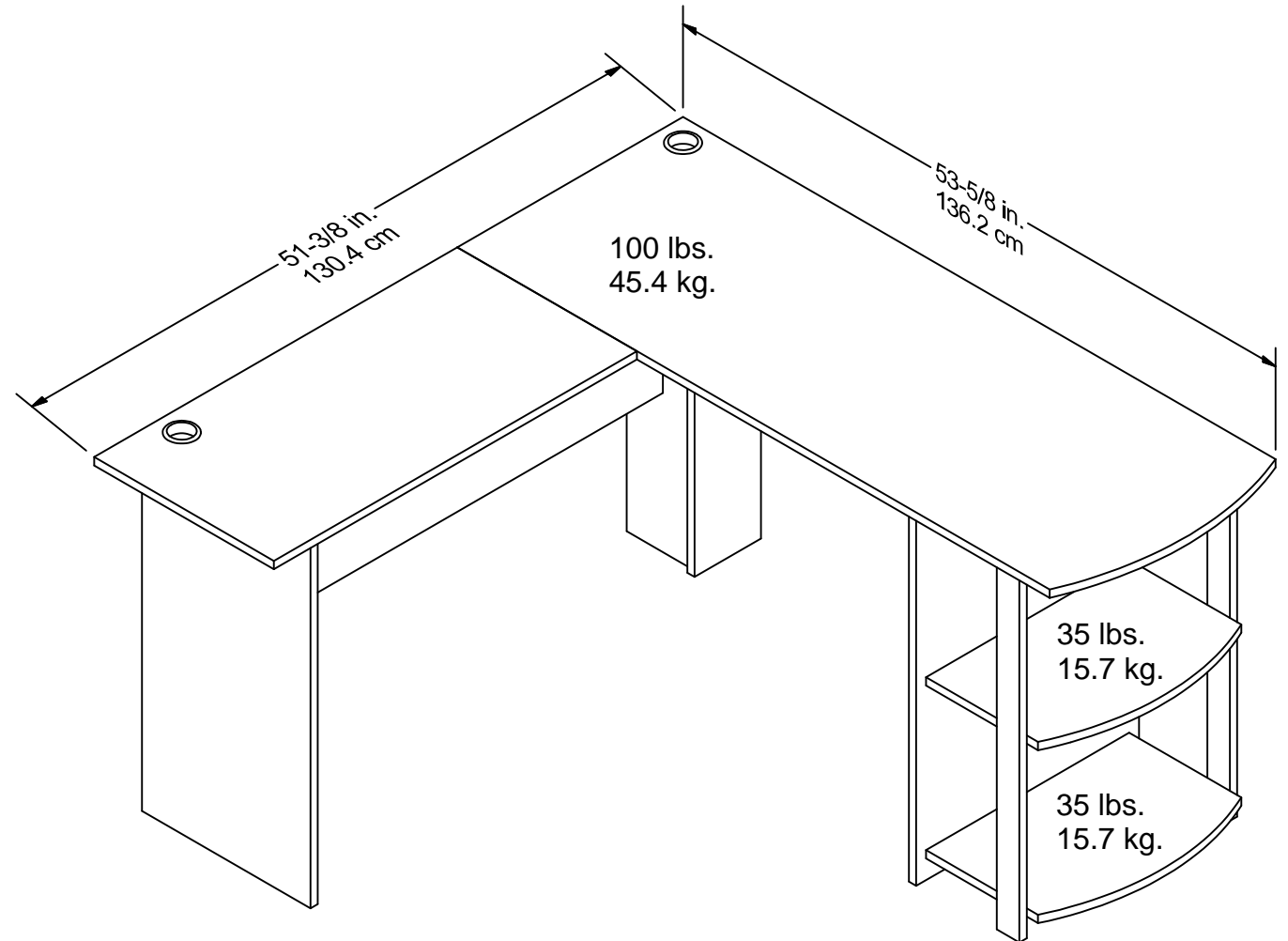

This unit has been designed to support the maximum loads shown. Exceeding these load limits could cause sagging, instability, product collapse, and/or serious injury.

Esta unidad ha sido diseñada para soportar la carga máxima anotada. El exceder estos límites puede causar inestabilidad, colapsarse y/o causar serias lesiones.

Ce meuble a été conçu pour supporter les charges maximales indiquées. En excédant ces limites de charge, le meuble pourrait devenir instable, s'effondrer, et/ou causer des blessures graves.

Certificate of Conformity

1. This certificate applies to the Ameriwood Industries Inc. product identified by this instruction manual.
 2. This certificate applies to compliance of this product with the CPSC Ban on Lead-Containing Paint (16 CFR 1303).
 3. This product is distributed by: Ameriwood Industries Inc.
410 East First Street South
Wright City, MO 63390
636-745-3351
 4. Site of Manufacture:
 - Tiffin OH
 5. See front page of instruction manual for date of manufacture.
-