



IF PARTS ARE MISSING AND OR DEFECTIVE, INSTRUCTIONS ARE NOT CLEAR
OR YOU ARE EXPERIENCING PROBLEMS ASSEMBLING OUR PRODUCT.

**BEFORE YOU RETURN THE PRODUCT TO THE STORE,
PLEASE CALL US TOLL FREE FOR CUSTOMER SERVICE ASSISTANCE**

(888) 777-8250

OR SEND US EMAIL AT

help@spartakent.com

PLEASE HAVE ITEM NUMBER READY, AND A REPRESENTATIVE WILL GLADLY ASSIST YOU

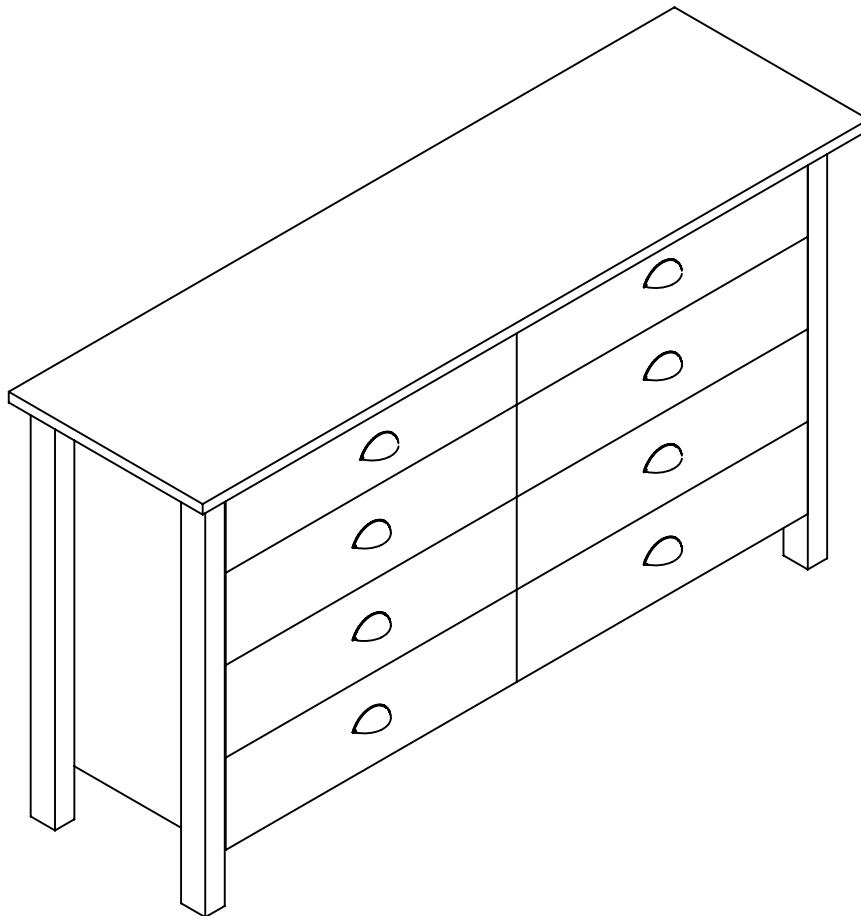





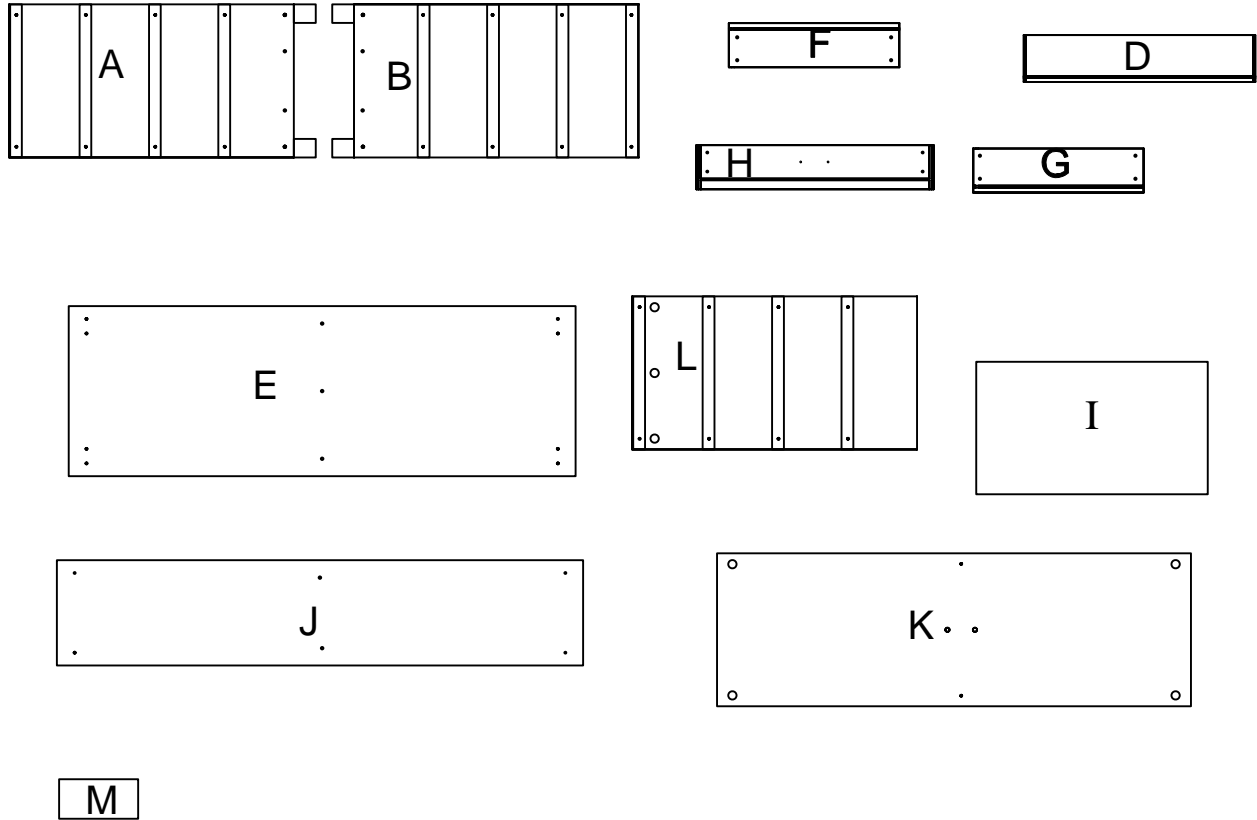









PARTS IDENTIFICATION

NOTE: FIRST MAKE SURE THAT YOU HAVE ALL OF THE PARTS LISTED ON THIS SHEET. IF YOU ARE MISSING ANY PIECE(S), DO NOT ASSEMBLE THE UNIT. INSTEAD, CALL CUSTOMER SERVICE NUMBER AT: (888) 777-8250. WE WILL BE HAPPY TO ASSIST YOU.

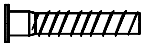

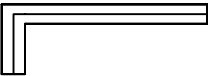
3117A-Side Panel Left	1pc	3027G-Drawer Right Side	8pcs
3117B-Side Panel Right	1pc	3027H-Drawer Front	8pcs
3027D-Drawer Back	8pcs	3027I- Drawer Bottom	8pcs
3117E-Top	1pcs	3117J-Back Panel	2pcs
3027F-Drawer Left Side	8pcs	3117K-Bottom	1pc
		3117L-Divider	1pc
		3117M-Center Support	1pc

HARDWARE LIST

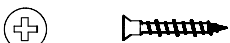
HARDWARE	PART NUMBER	DESCRIPTION	QTY
 	CAMLT12	CAMLOCK	7
	CAMBT16	BOLT	7
	DOWW830	WOOD DOWEL	8
	GLIDE22MM	GLIDE	5
	PUSH	SHELL METAL PULL	8
	SRM815B	MACHINE SCREW	16
	GLUEWD	GLUE	2
	NAIL1734	NAIL	24
	SCF507HB	CONFIRMAT SCREW	2
	SFH845A	WOOD SCREW	6
	ALLEN4	HEX KEY	1
	BM25	ANGLE BRACKET	32
	SPE610BL	EURO SCREW	64
	SC--S	SCREW COVER CAP	4
	SP811BL	PAN HEAD SCREW	12
	SFH833A	WOOD SCREW	32

1

When first inserting camlocks, make sure they always point towards edge of board as indicated.

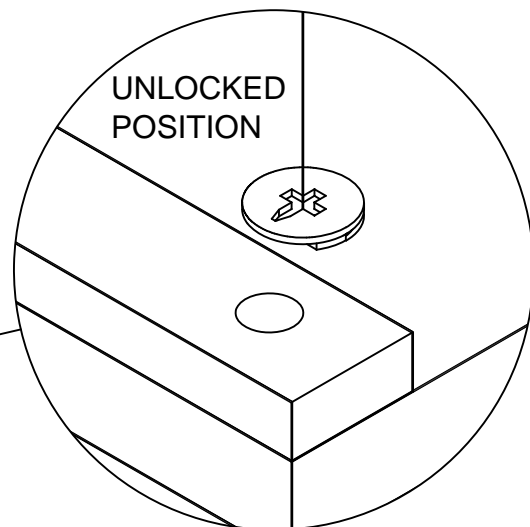
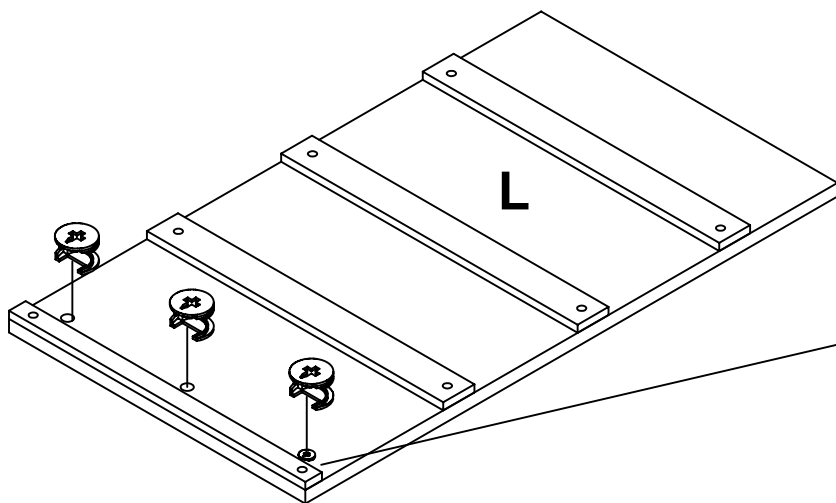
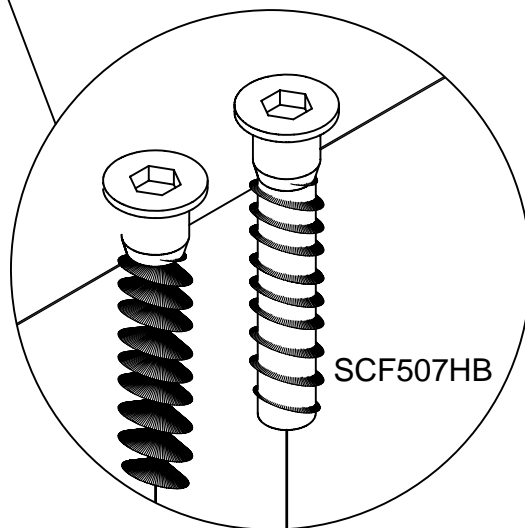
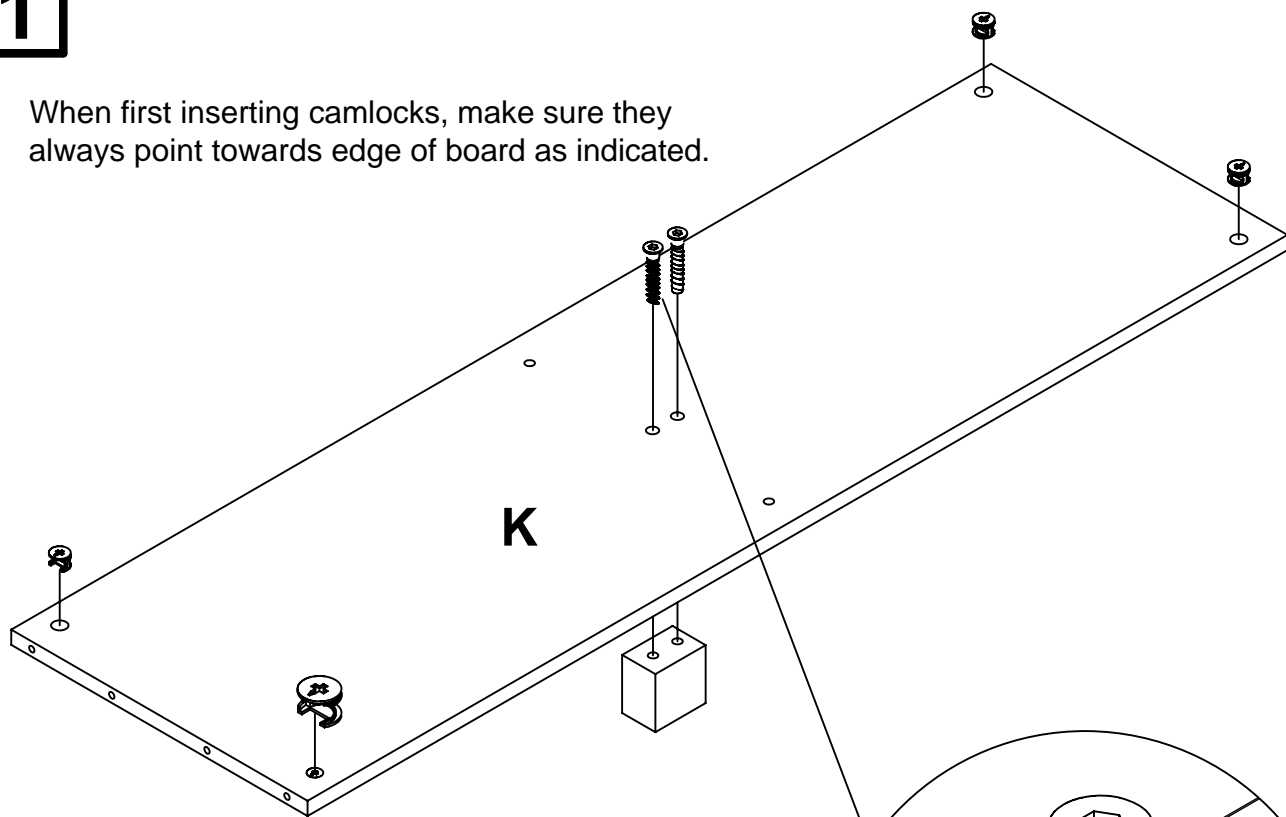

2

When first inserting camlocks, make sure they always point towards edge of board as indicated.

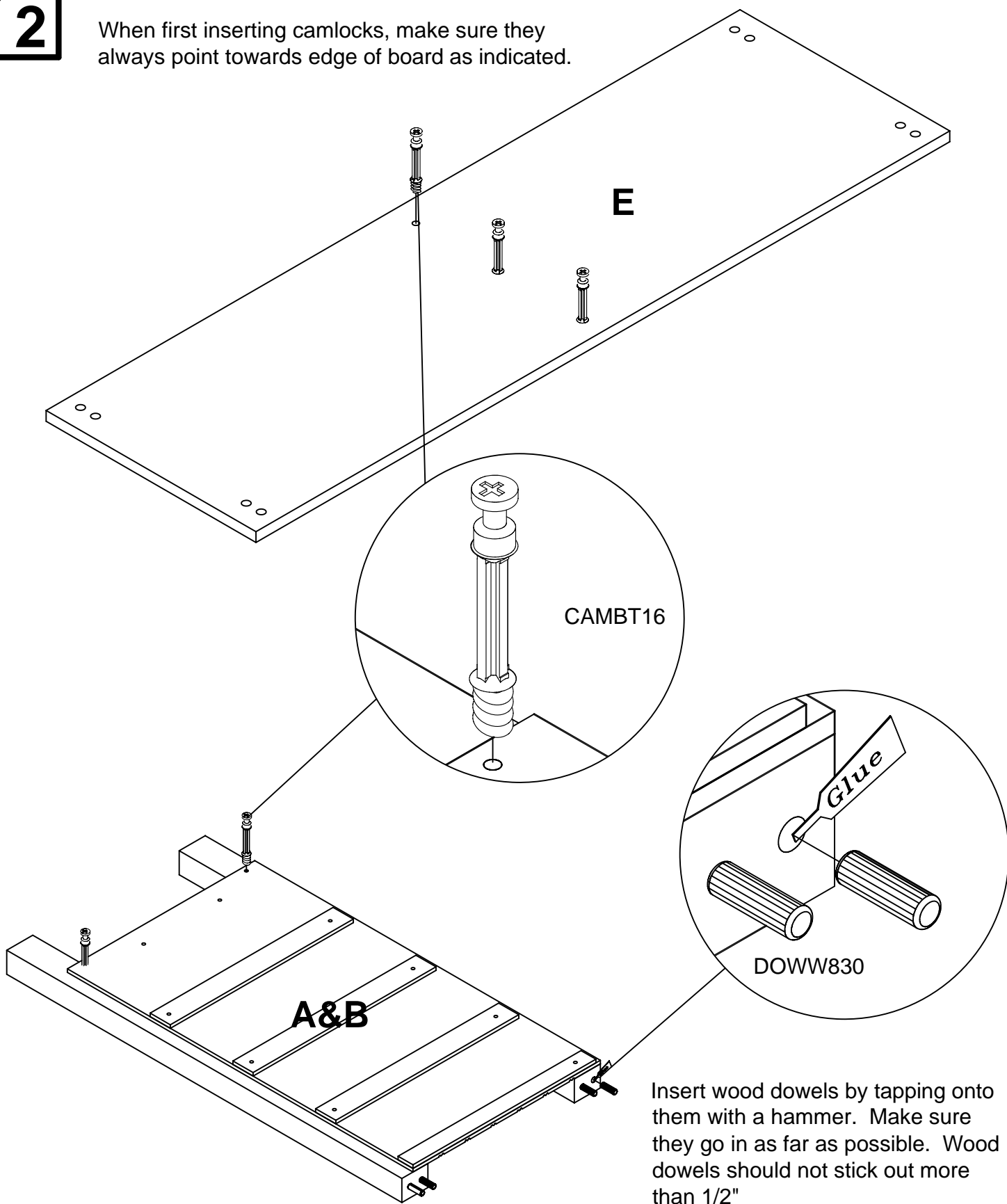

3

When locked, arrow on camlock should point away from the edge as indicated.

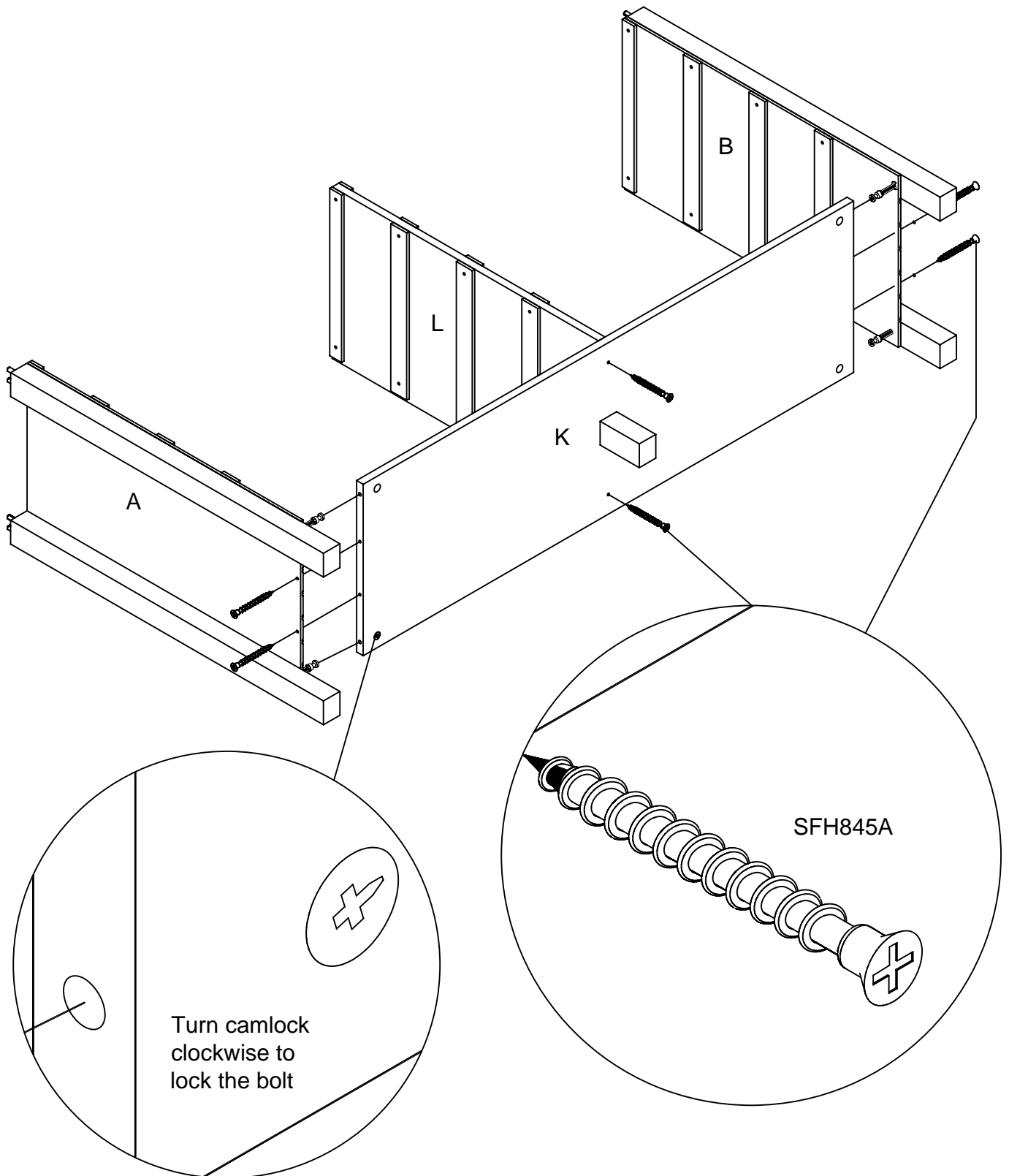

4

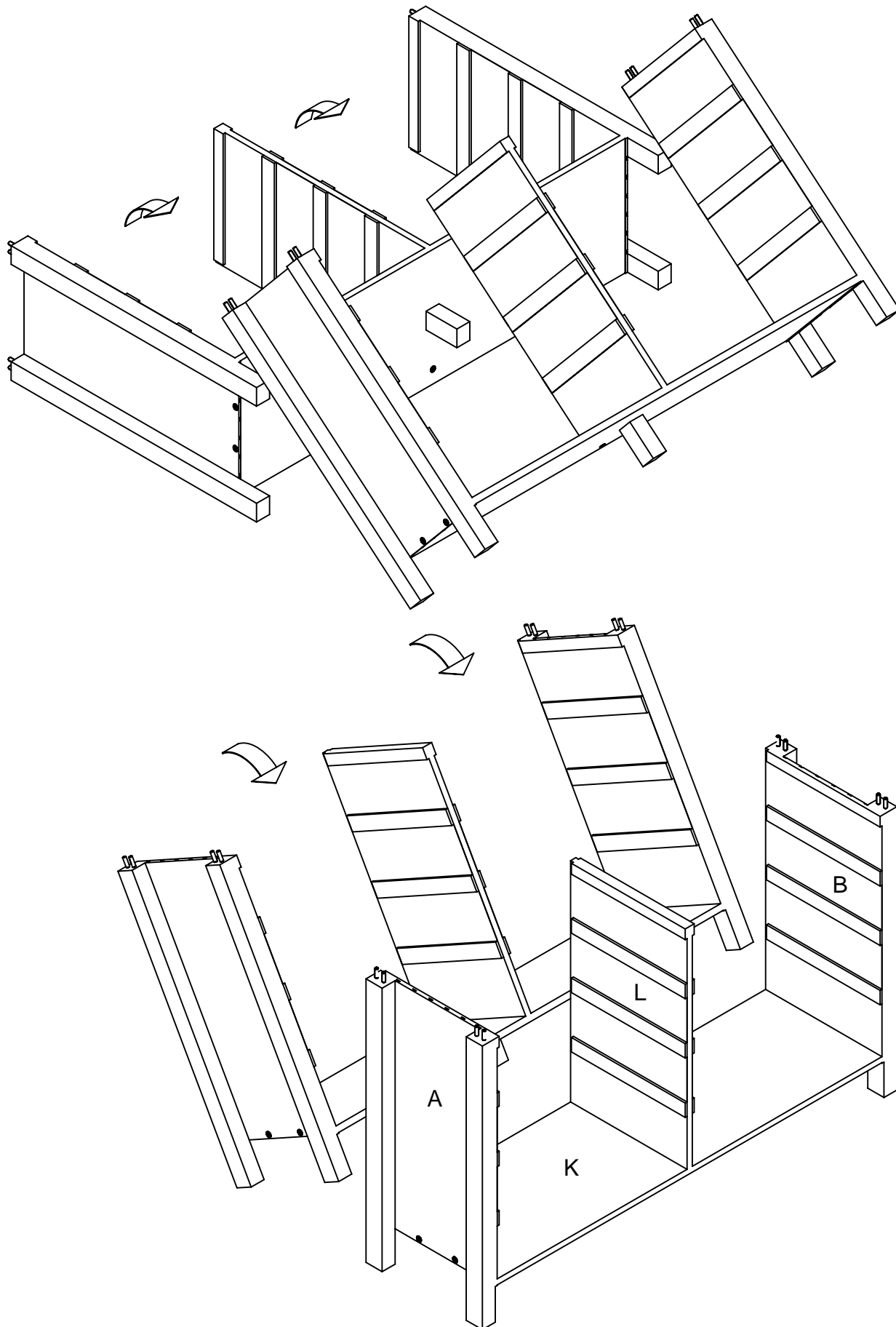

Handle the assembly with care to avoid damage of bottom part (K).

5

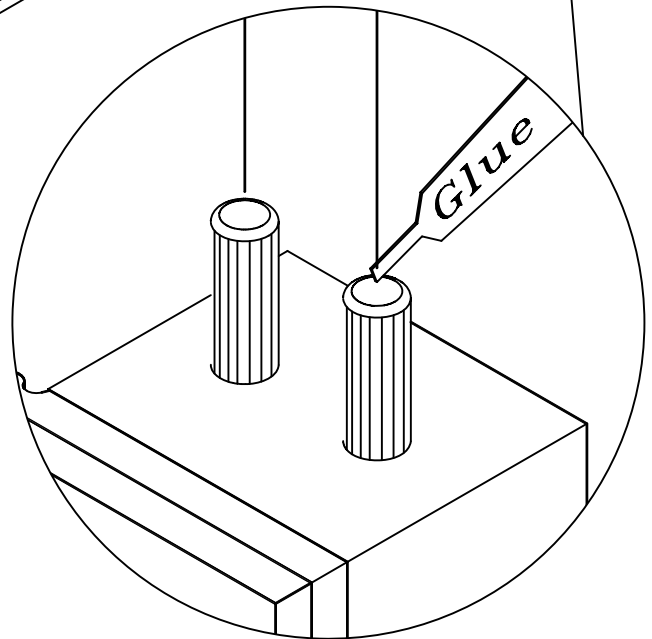
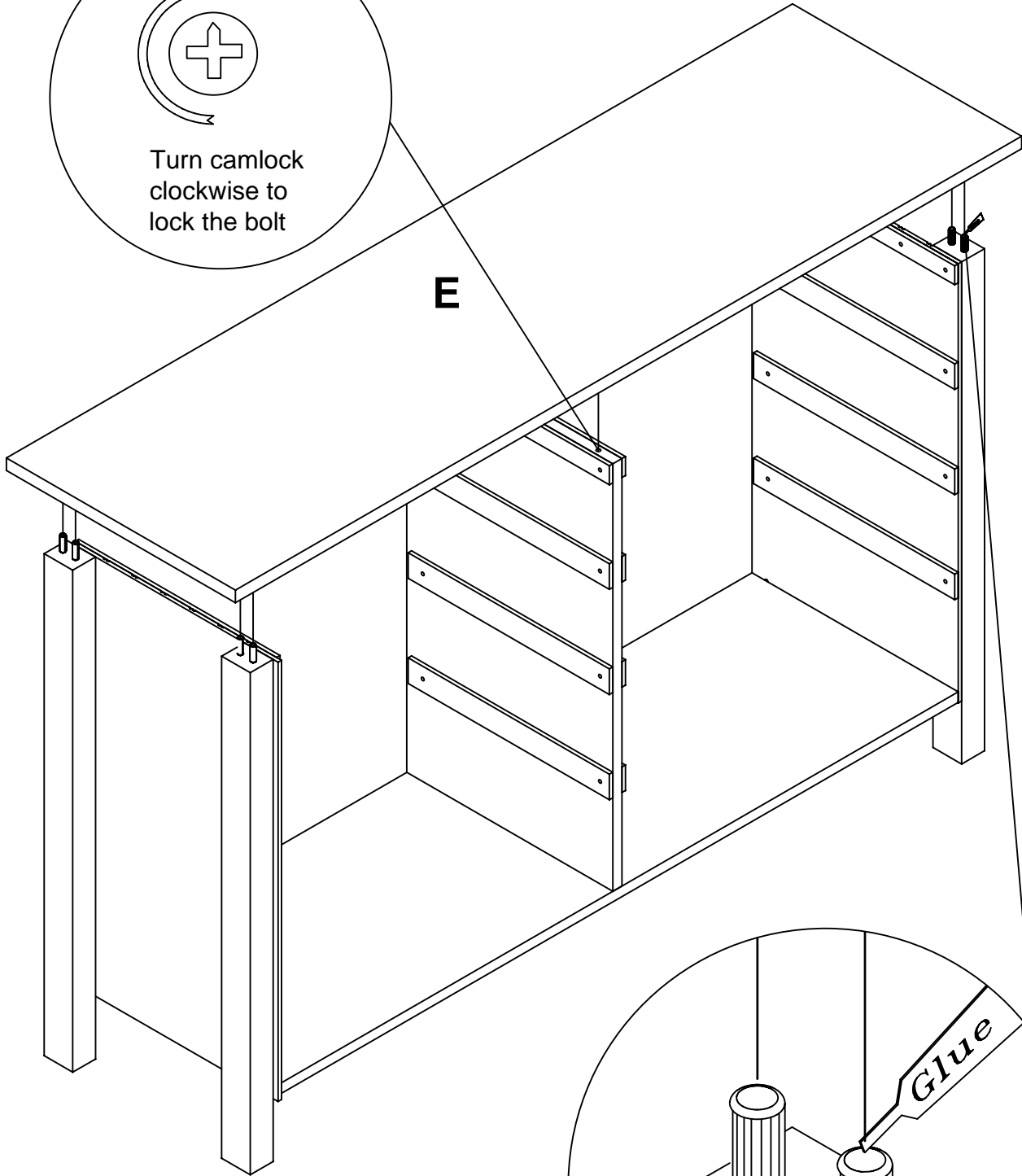
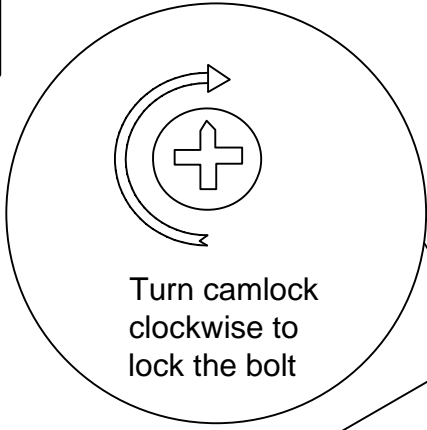

Press down onto the Top to make sure wood dowels go in all the way and that there is no gap left between Sides and the Top.

6

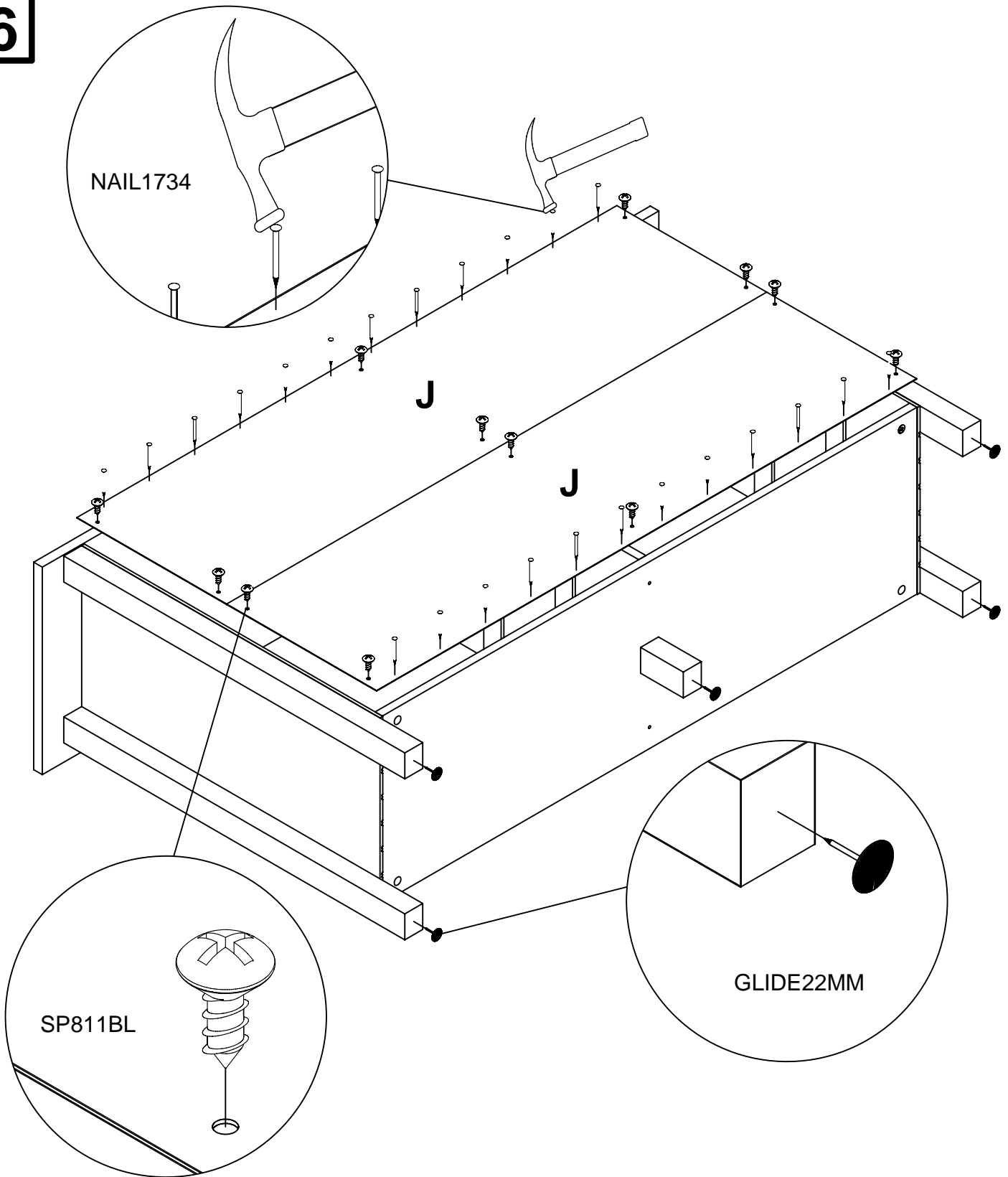

Place the unit face down. Align the Back Panel (J) over the of the unit. Make sure the assembly is square and leave equal amount of margin all around. Secure the panel by screwing 6 screws through the pre-drilled holes for both panels (2 screws on both ends and 2 screws in the center). Next, nail the top and bottom (as shown above) with approximately 4" spacing between the nails. Make sure to keep the nails centered on the edges to avoid splitting of the boards.

7

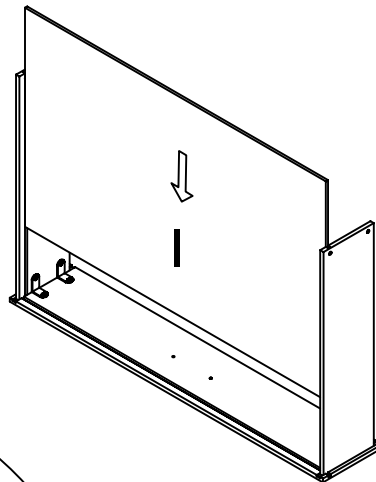
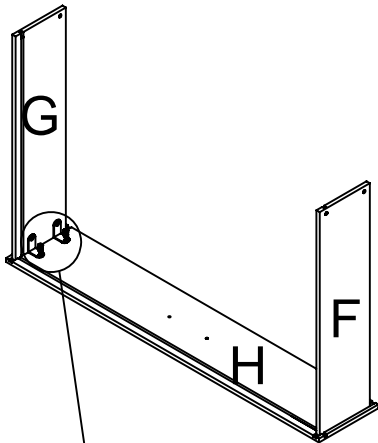
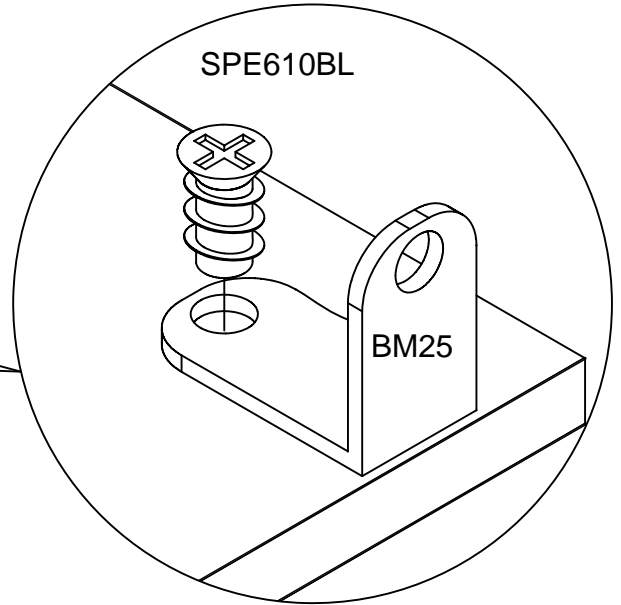
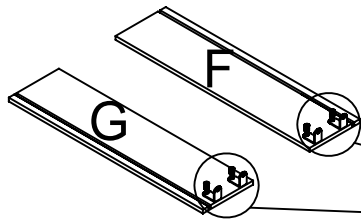

Note: Once parts (F and G) have been attached to part (H) with the euro screws, a total of four each. Then slide in the bottom part of the drawer (Part I).

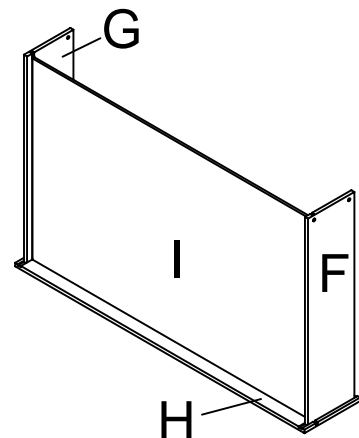
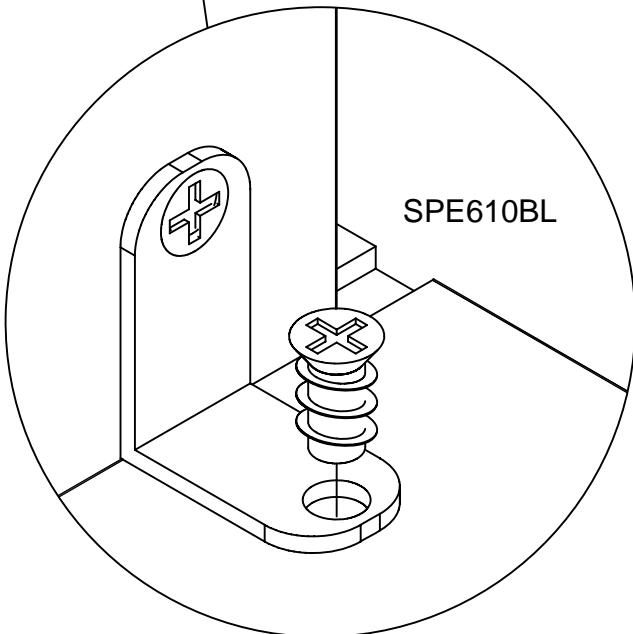

8

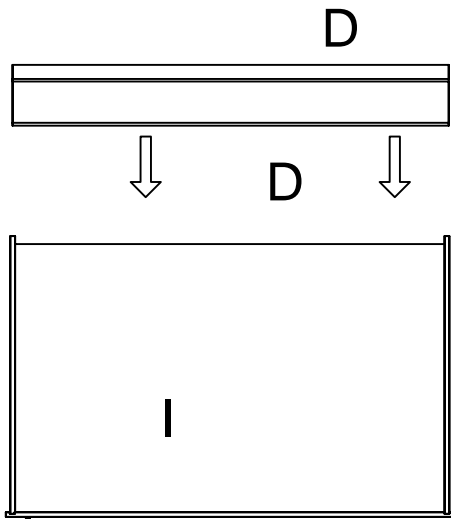

Place (D) onto (in between) Drawer Sides (F) and (G). Repeat last steps for the rest of the drawers.

Note: Attach part (D) with two screws on both sides (Parts F & G) a total of four screws as shown below.

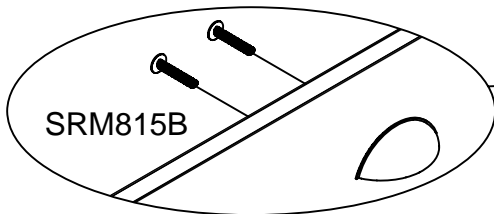
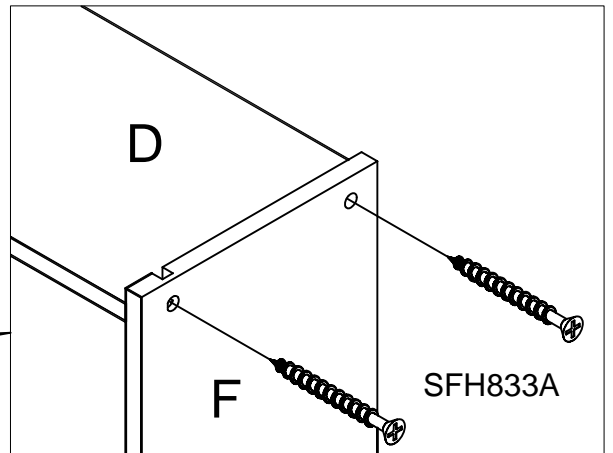
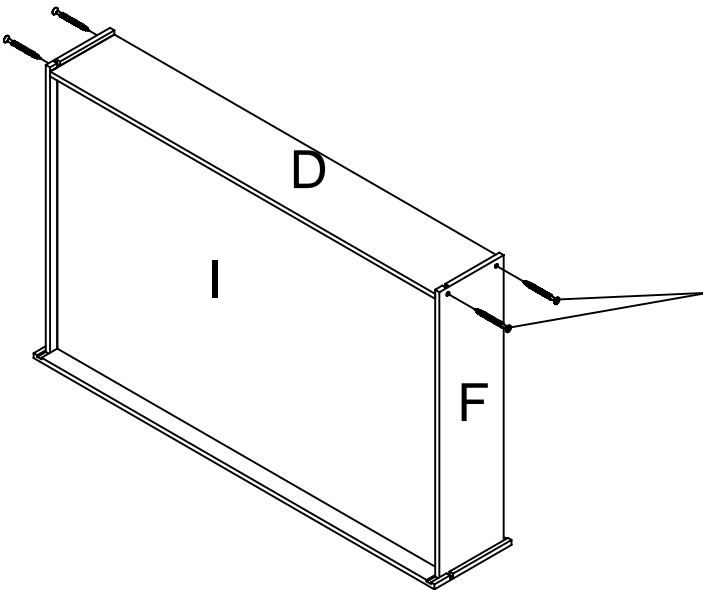

Note: Attach the handle with two screws as shown to the right.

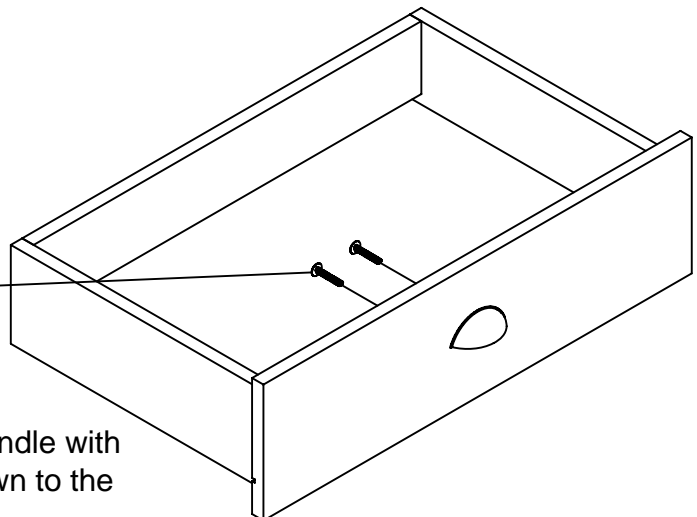

Note: Insert the drawers by following the diagram below. Start from the bottom and work your way up. This way you can have a clear view where to insert the next drawer.

