



IF PARTS ARE MISSING AND OR DEFECTIVE, IF INSTRUCTIONS ARE NOT CLEAR
OR IF YOU ARE EXPERIENCING PROBLEMS ASSEMBLING OUR PRODUCT.

**BEFORE YOU RETURN THE PRODUCT TO THE STORE,
PLEASE CALL US TOLL FREE FOR CUSTOMER SERVICE ASSISTANCE**

(888) 777-8250

OR SEND US EMAIL AT

help@spartakent.com

PLEASE HAVE ITEM NUMBER READY, AND A REPRESENTATIVE WILL GLADLY ASSIST YOU

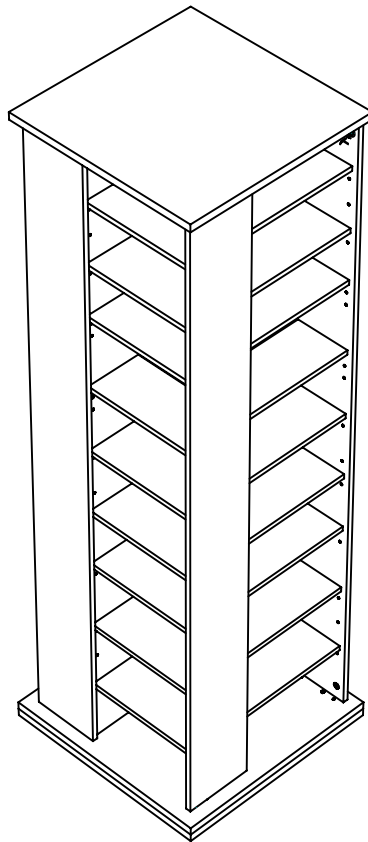

HARDWARE	PART #	DESCRIPTION	QTY
	CCPZXX	CAMLOCK COVER CAP	16
	CAMLT12	CAMLOCK	16
	CAMBT16	BOLT	16
	BM25	BRACKET ANGLE	8
	SPE610BL	EURO SCREW	16
	BPXX54	SHELF SUPPORT	144
	TRNTPL	SWIVEL PLATE	1
	TRNTSC	SWIVEL BOLT	1
	DOWW830	WOOD DOWEL	4

TOOL REQUIRED

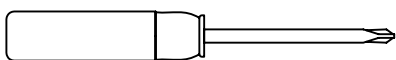

PHILLIPS SCREWDRIVER

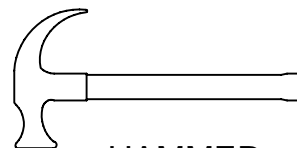

HAMMER

PARTS IDENTIFICATION

NOTE: FIRST MAKE SURE THAT YOU HAVE ALL OF THE PARTS LISTED ON THIS SHEET. IF YOU ARE MISSING ANY PIECE(S), DO NOT ASSEMBLE THE UNIT. INSTEAD, CALL OUR CUSTOMER SERVICE NUMBER AT: (888) 777-8250. WE WILL BE HAPPY TO ASSIST YOU.

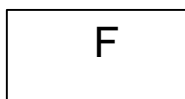
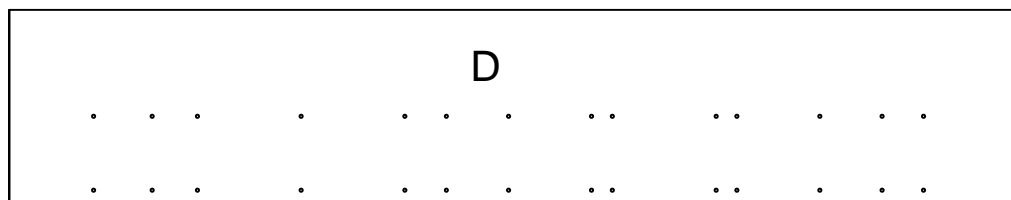
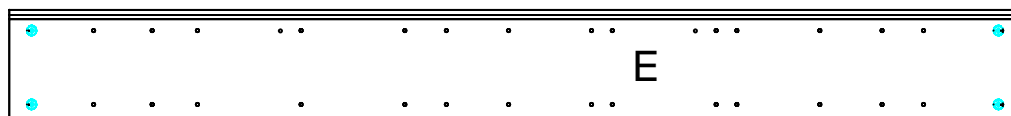
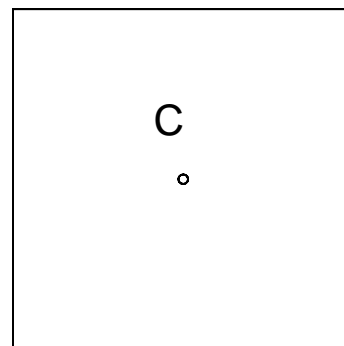
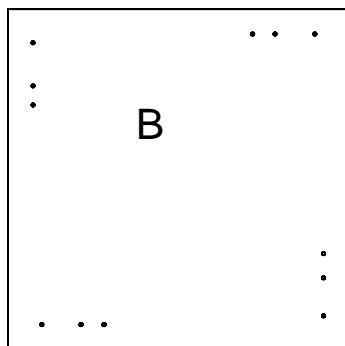
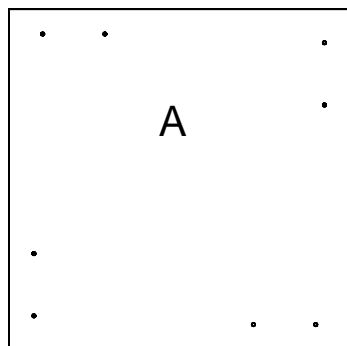

2380A-Top 1pc
2380B-Bottom 1pc
2380C-Base 1pc

2390D-Divider 4pcs
2390E-Face Panel 4pcs
2390F-Adjustable Shelf 36pcs

PARTS ARE USUALLY MARKED ON THE RAW EDGE

1

Do not tighten screw on the angle bracket all the way in this step. Leave it a bit loose until you attach part D in the next step. Then you will tighten the screws.

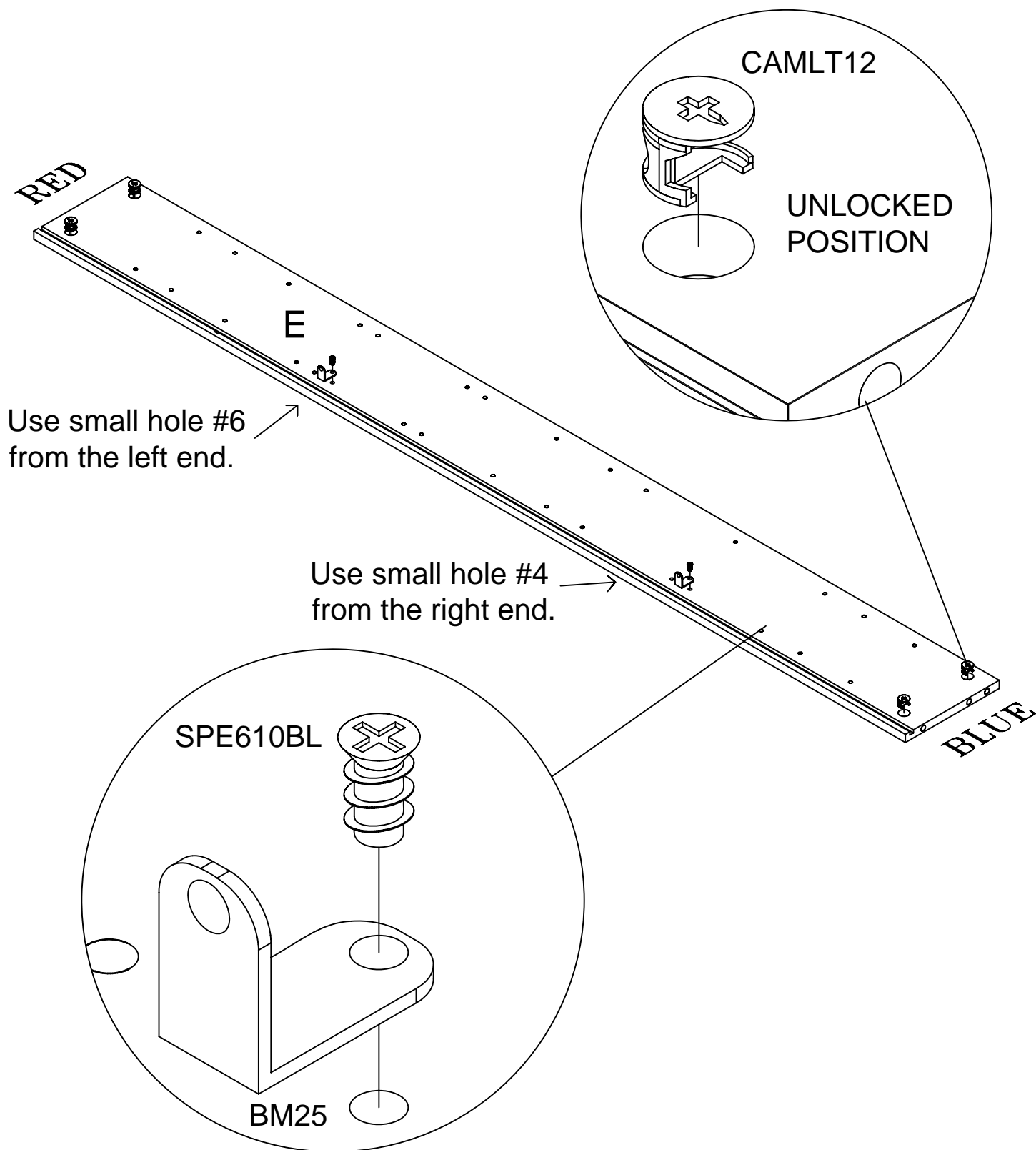

2

Press part (D) in the groove of part (E). The holes in part (D) should face away from part (E), except for holes where brackets are attached, and RED marked end of it should be on the same side as on part (E). Make sure part (E) and (D) are aligned with each other on both ends.

If you experience difficulty in lining up boards E and D with the angle brackets, try the following:

1) loosen the screw on the angle bracket attached to board E,

2) line up angle bracket hole with board D and attach screw into bracket and hole on board D,

3) tighten screws on boards D and E until both board are pulled together and fit properly.

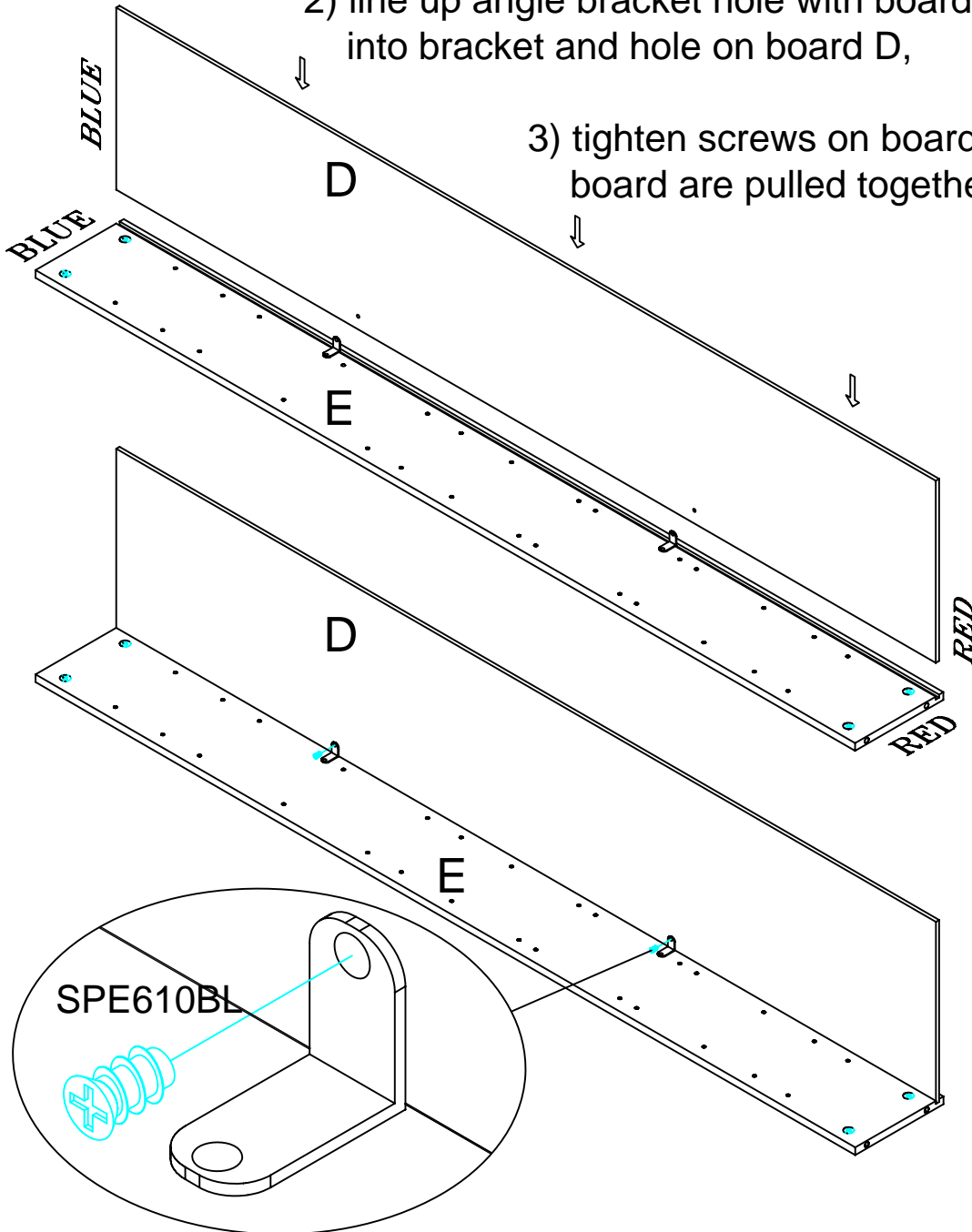

Repeat steps 1 and 2 for the remaining three sets of part (D) & (E)

3

First Step

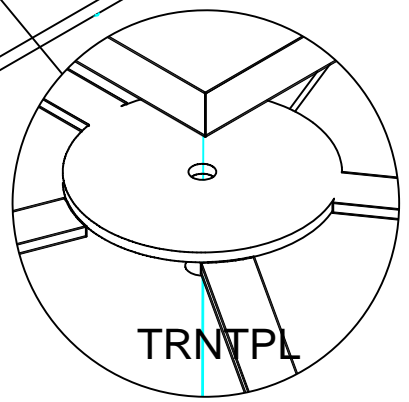
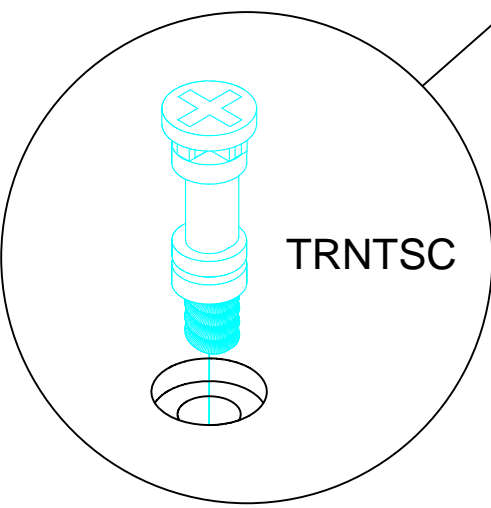
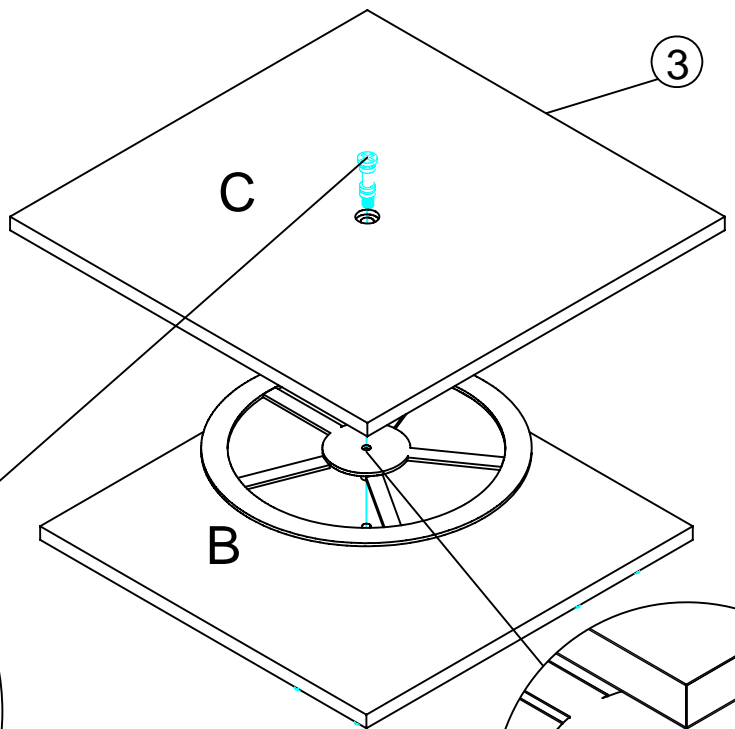
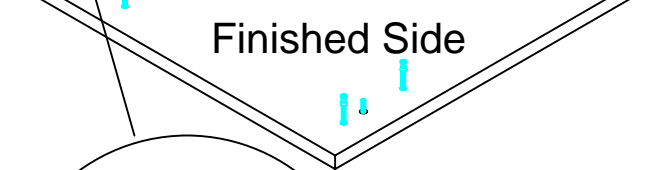
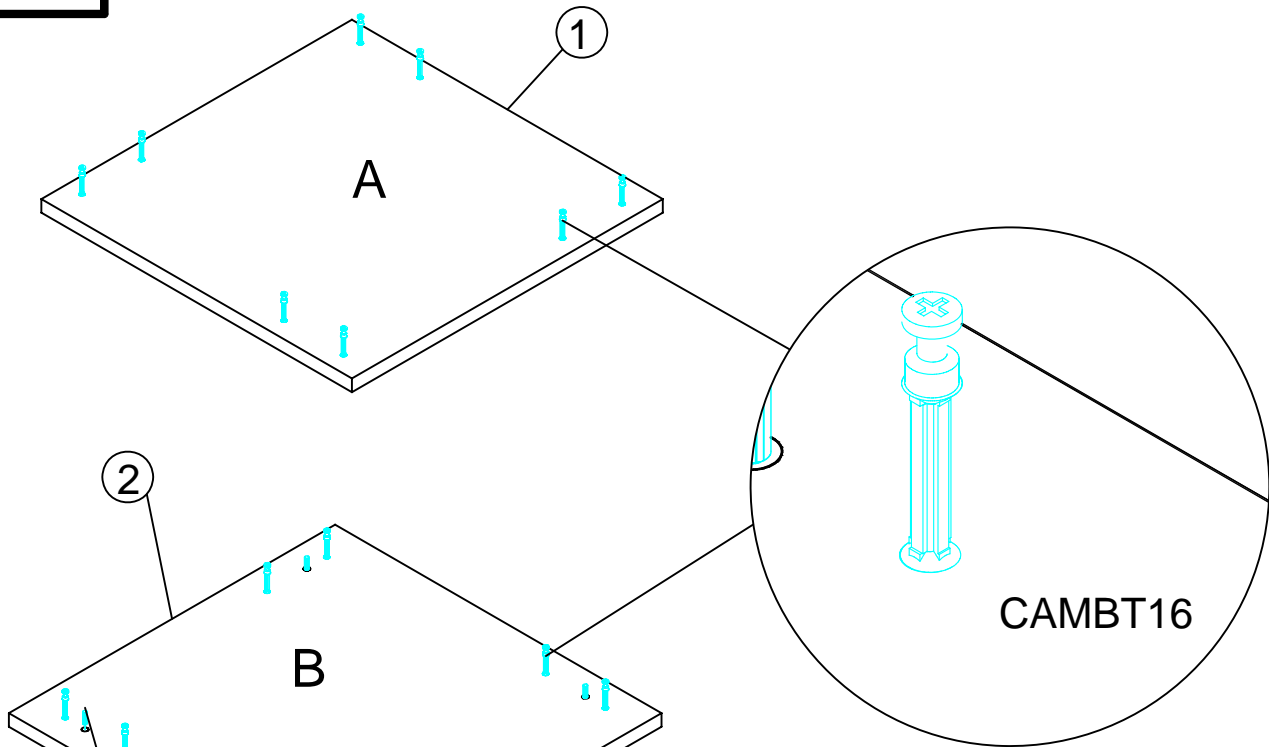

4

Lock camlocks on panels E as you install them before you proceed to next one. Otherwise panels may fall over and cause damage. Make sure you have on top only RED marked ends of panels D & E

1

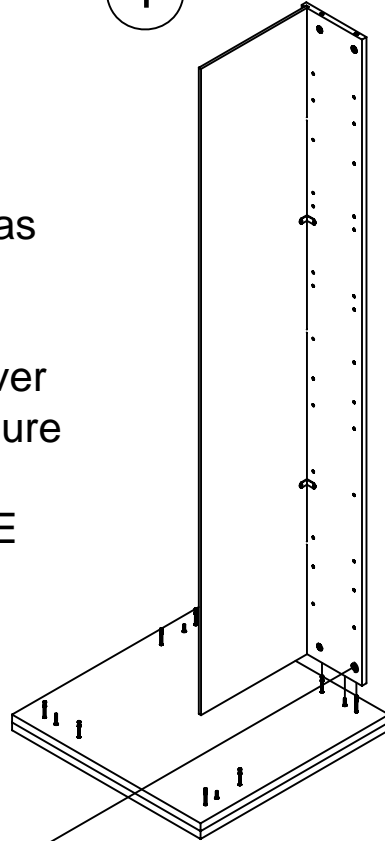

2

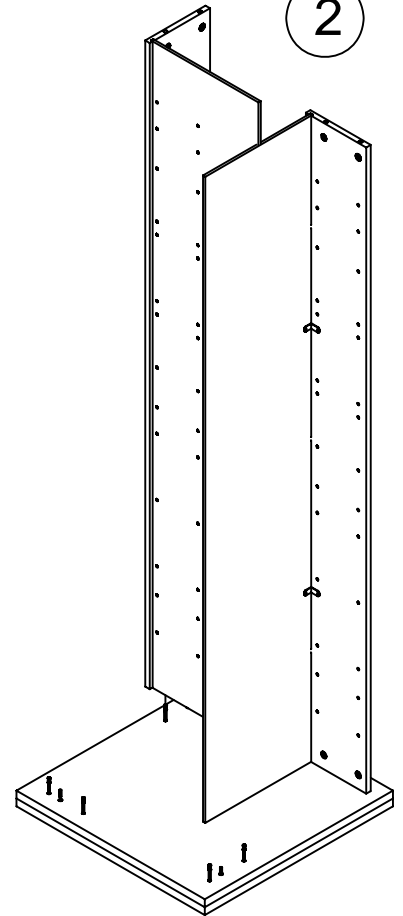

3

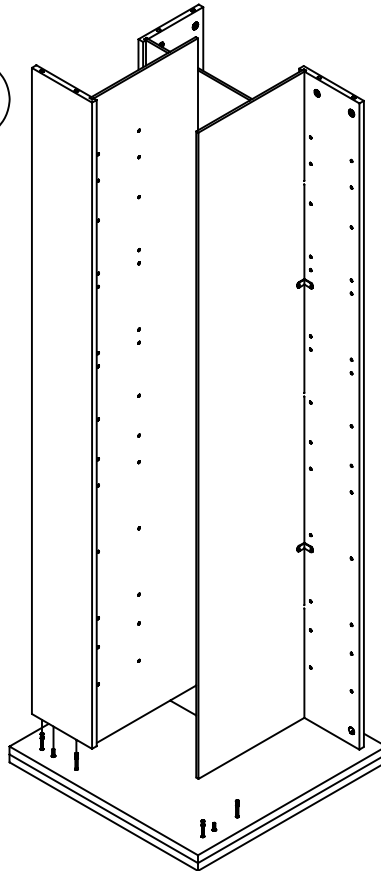

4

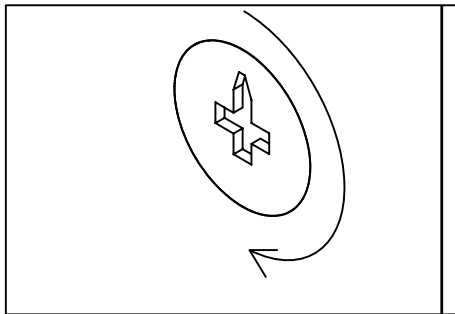
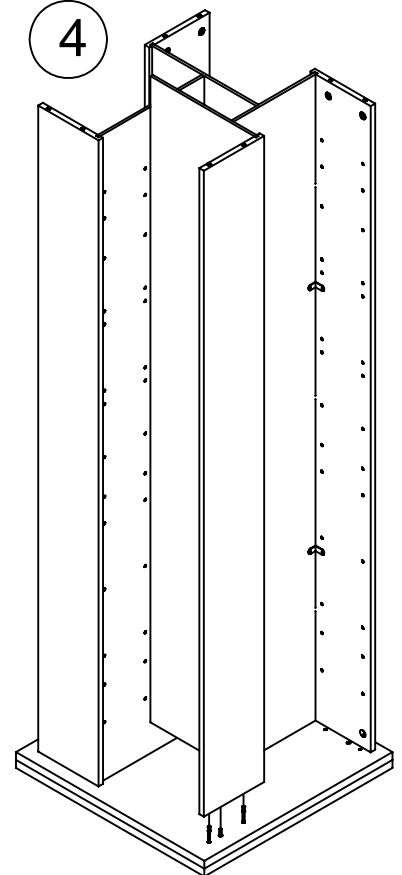

Turn camlocks clockwise using flat (preferred) or phillips scrudriver until full stop (slightly over $\frac{1}{2}$ a turn to lock the bolt)

5

Install top first. Next install one shelf in the middle (hole#8) on each side to restrict movement of inside dividers D. Do not tap with hammer onto shelf supports, instead twist them when inserting in.

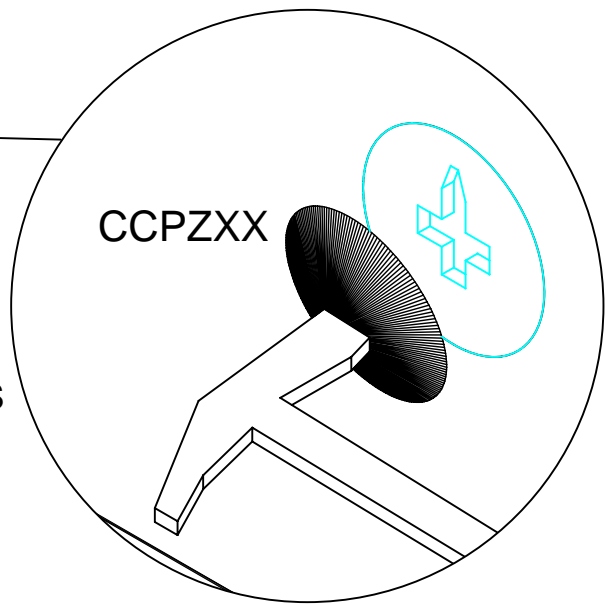
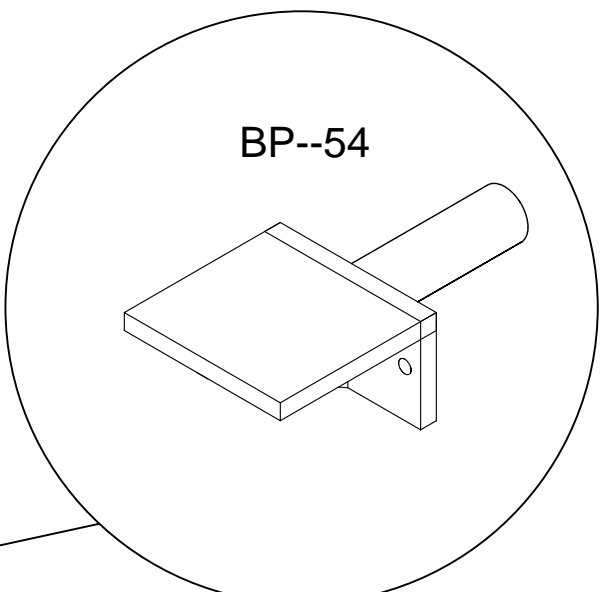
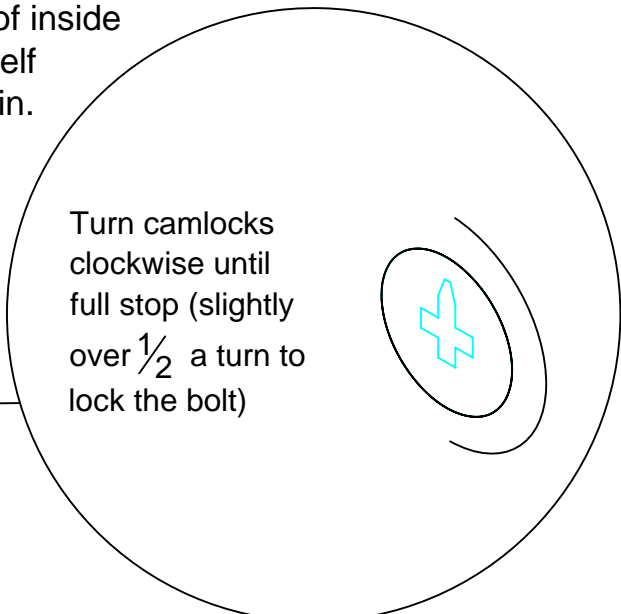
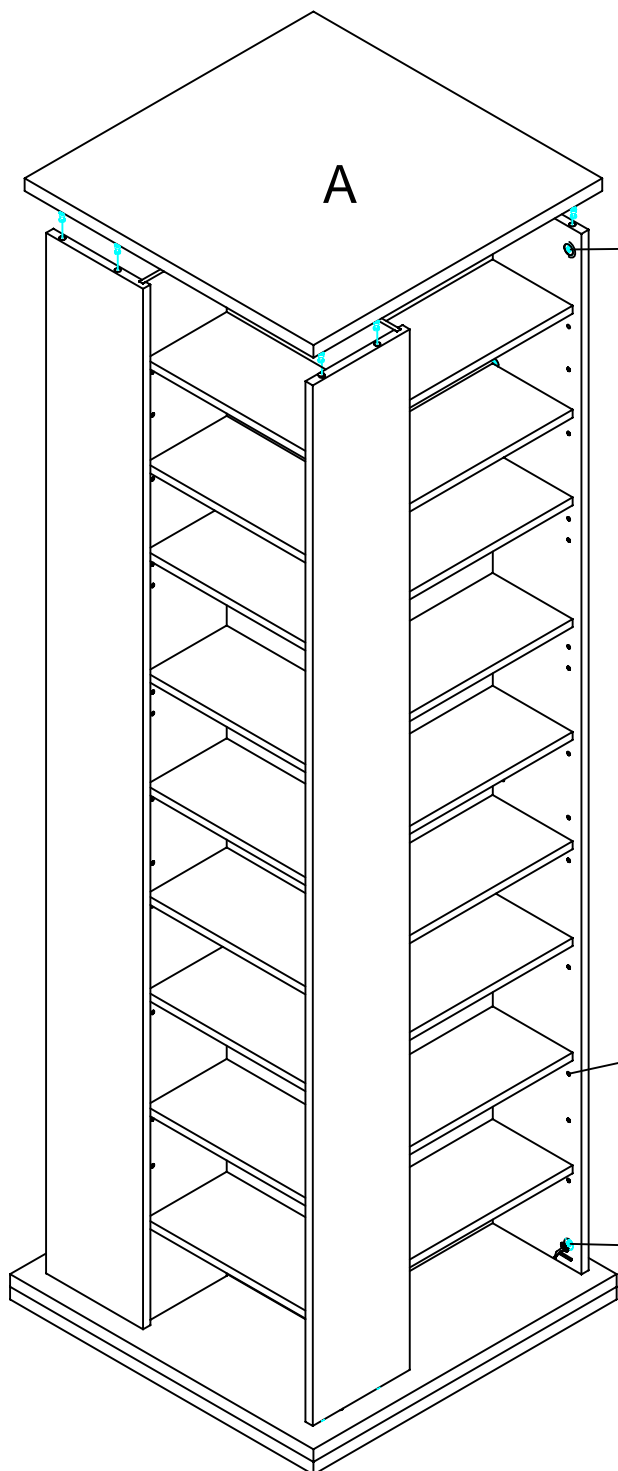

If you'd like to optimize the space for CD or DVD/VHS only, then use these holes (counting from the top):

CD 1 3 5 6 8 10 11 12 14 15 -10 spaces

DVD/vhs 2 4 6 8 10 12 -7 spaces