



IF PARTS ARE MISSING AND OR DEFECTIVE, IF INSTRUCTIONS ARE NOT CLEAR
OR IF YOU ARE EXPERIENCING PROBLEMS ASSEMBLING OUR PRODUCT.

**BEFORE YOU RETURN THE PRODUCT TO THE STORE,
PLEASE CALL US TOLL FREE FOR CUSTOMER SERVICE ASSISTANCE**

(888) 777-8250

OR SEND US EMAIL AT

help@spartakent.com

PLEASE HAVE ITEM NUMBER READY, AND A REPRESENTATIVE WILL GLADLY ASSIST YOU

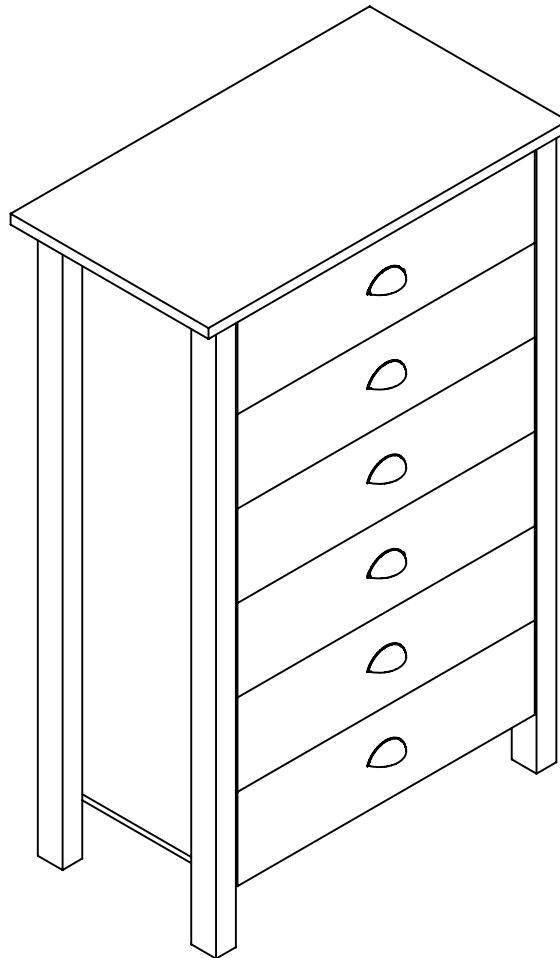





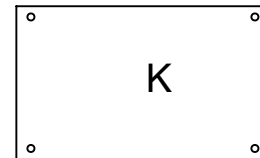
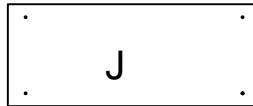
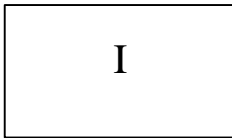
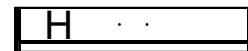
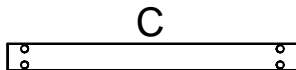
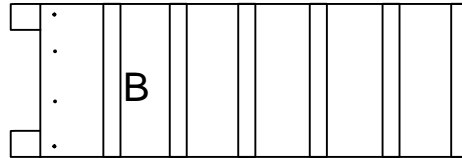
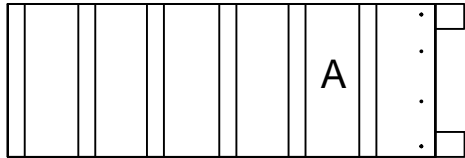







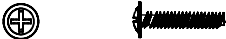

PARTS IDENTIFICATION

NOTE: FIRST MAKE SURE THAT YOU HAVE ALL OF THE PARTS LISTED ON THIS SHEET. IF YOU ARE MISSING ANY PIECE(S), DO NOT ASSEMBLE THE UNIT. INSTEAD, CALL CUSTOMER SERVICE NUMBER AT: (888) 777-8250. WE WILL BE HAPPY TO ASSIST YOU.

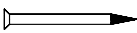

3077A-Side Panel Left	1pc	3027G-Drawer Right Side	6pcs
3077B-Side Panel Right	1pc	3027H-Drawer Front	6pcs
3077C-Center Support	2pcs	3027I- Drawer Bottom	6pcs
3027D-Drawer Back	6pcs	3027J-Back Panel	4pcs
3027E-Top	1pc	3027K-Bottom	1pc
3027F-Drawer Left Side	6pcs		

HARDWARE LIST

HARDWARE	PART NUMBER	DESCRIPTION	QTY
 	CAMLT12	CAMLOCK	12
	CAMBT16	BOLT	12
	DOWW830	WOOD DOWEL	8
	GLIDE22MM	GLIDE	4
	PUSH	SHELL METAL PULL	6
	SRM815B	MACHINE SCREW	12
	GLUEWD	GLUE	2
	NAIL1734	NAIL	40
	SFH833A	WOOD SCREW	28
	BM25	ANGLE BRACKET	24
	SPE610BL	EURO SCREW	48
	SC--S	SCREW COVER CAP	4
	SP811BL	PAN HEAD SCREW	16

1

When first inserting camlocks, make sure they always point towards edge of board as indicated.

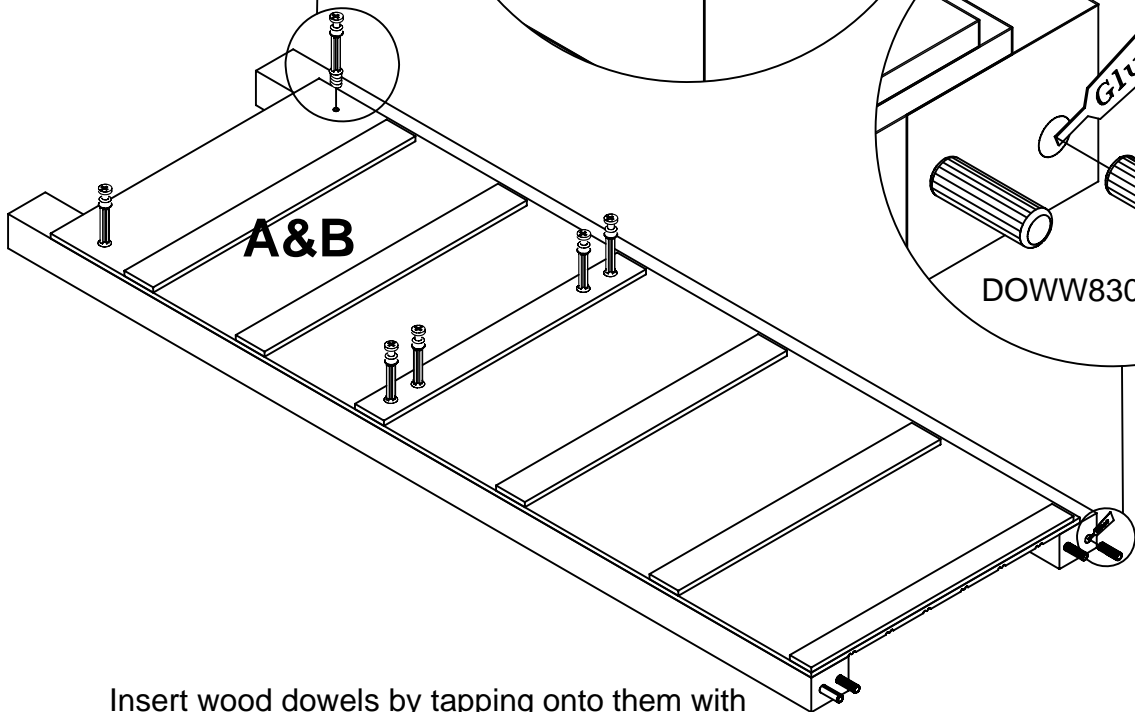
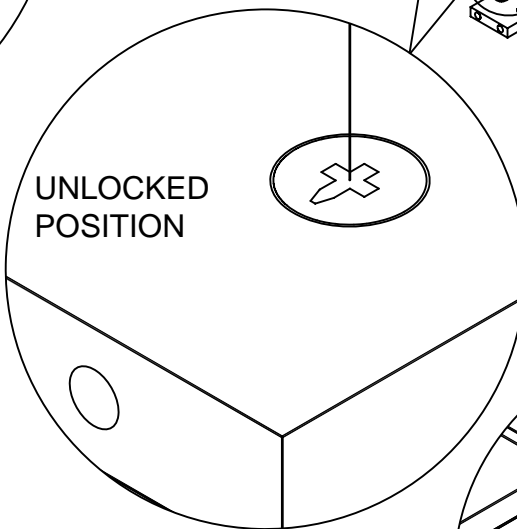
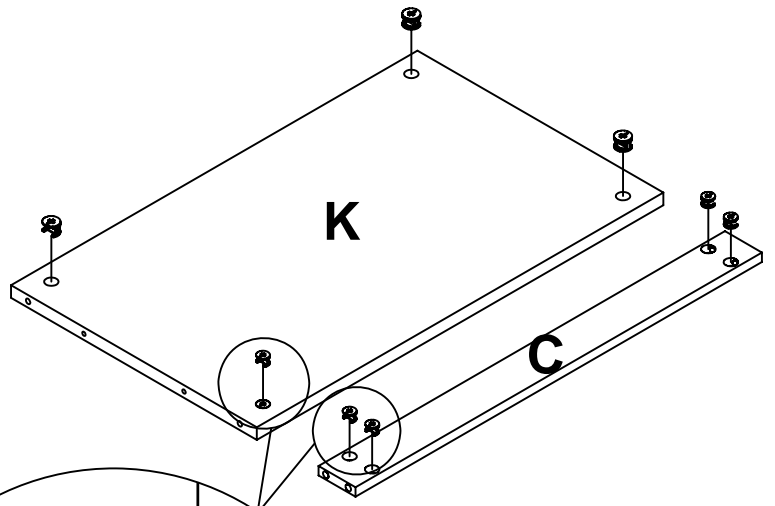
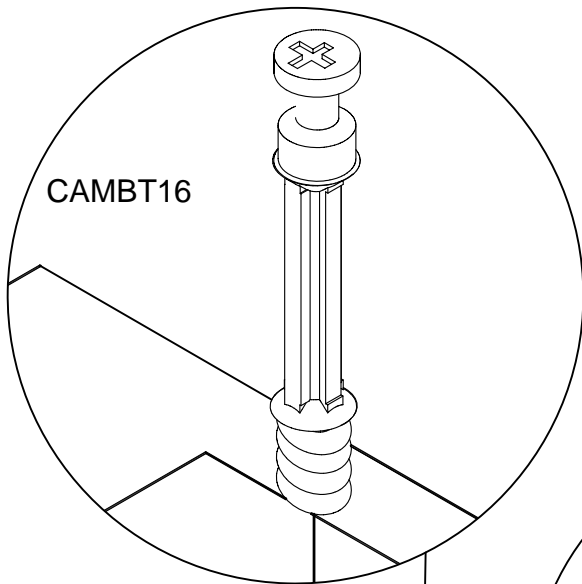

Insert wood dowels by tapping onto them with a hammer. Make sure they go in as far as possible. Wood dowels should not stick out more than 1/2"

2

When locked, arrow on camlock should point away from the edge as indicated.

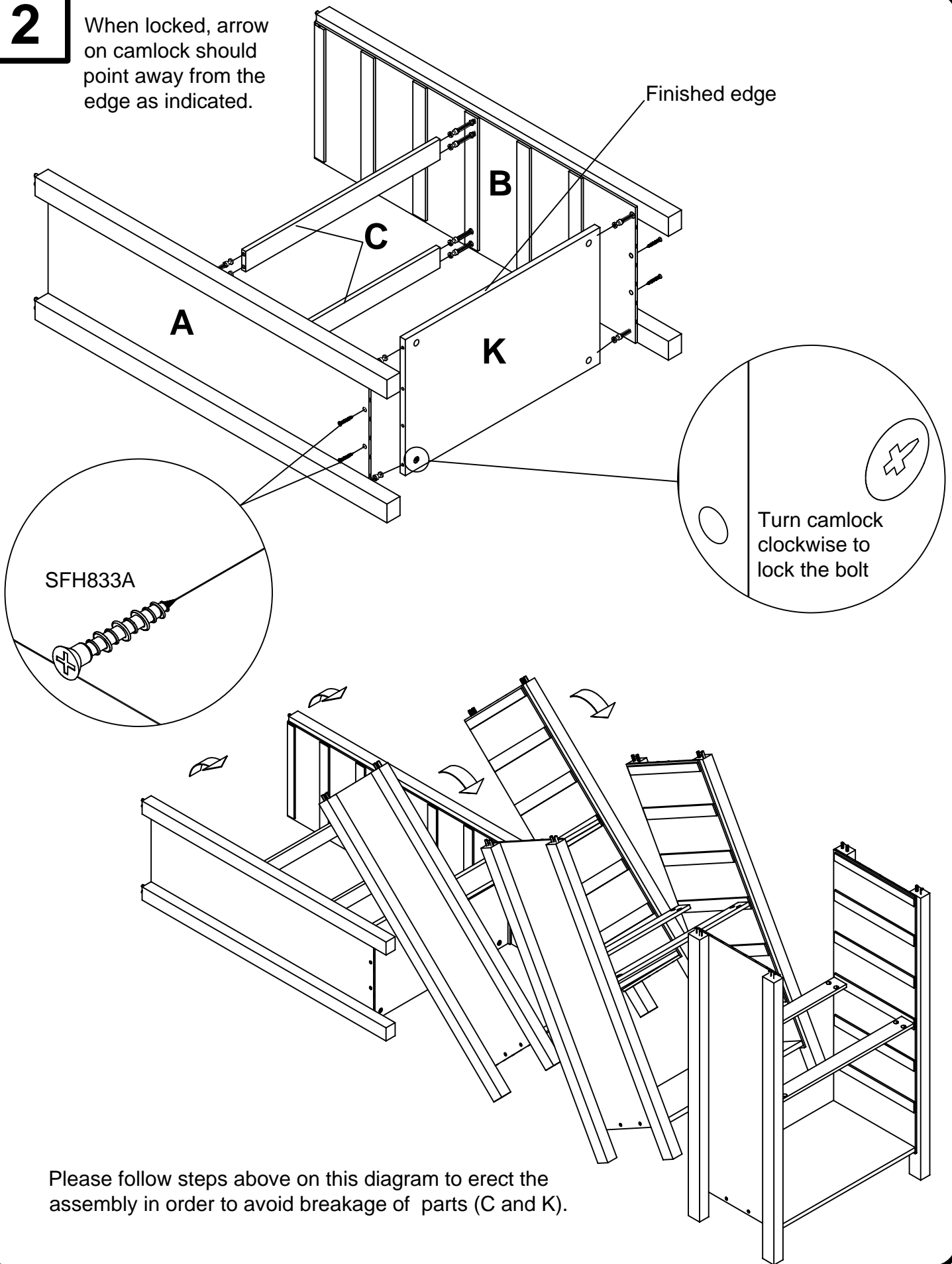

Please follow steps above on this diagram to erect the assembly in order to avoid breakage of parts (C and K).

3

Note: Make sure you align the raw edges of part (E) to parts (A and B) in the back when attaching. Lightly tap on the top piece (part E) onto the unit in order not to leave any gaps in between them. Be careful because you may not be able to undo this step once glue has set.

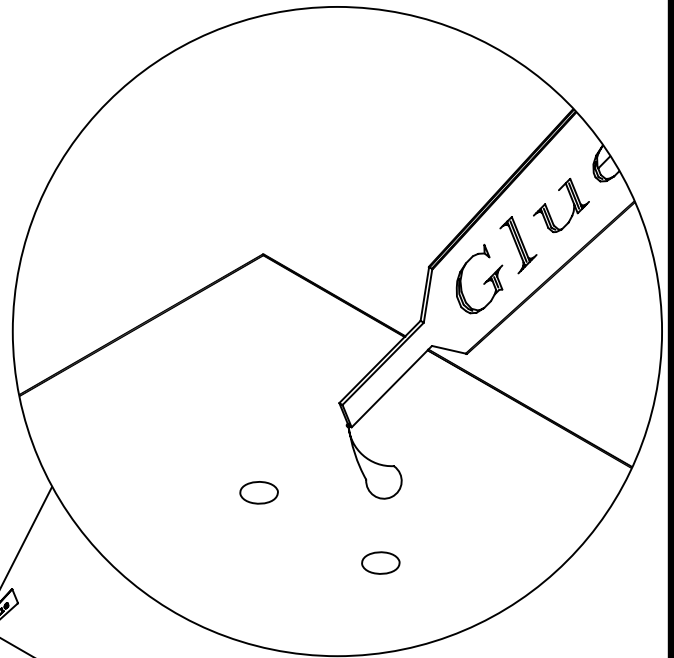
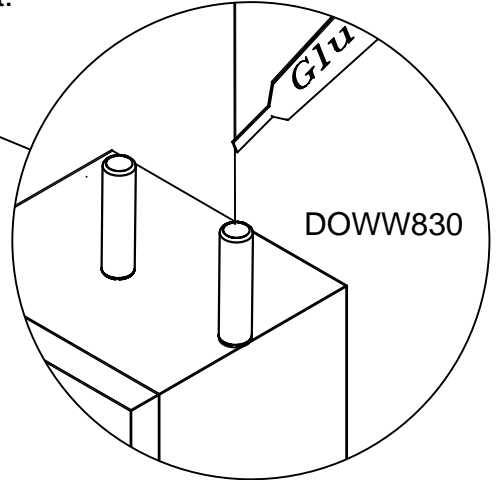
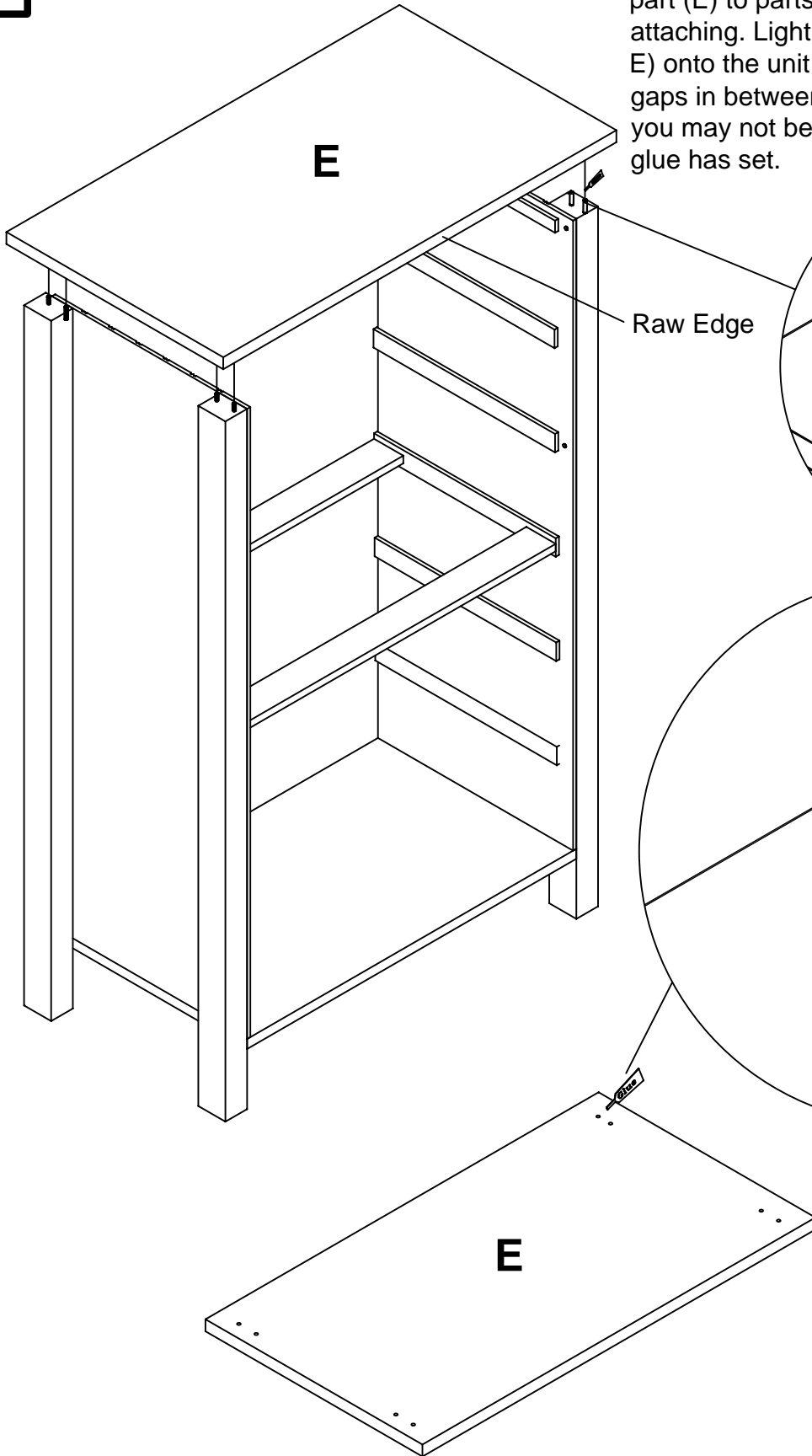

4

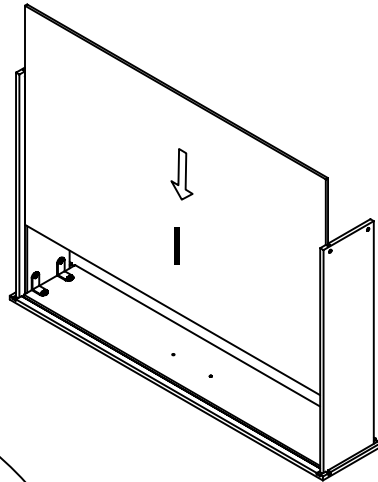
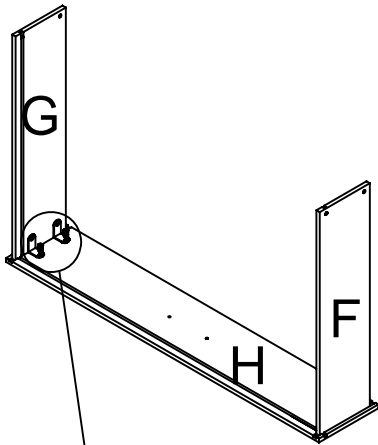
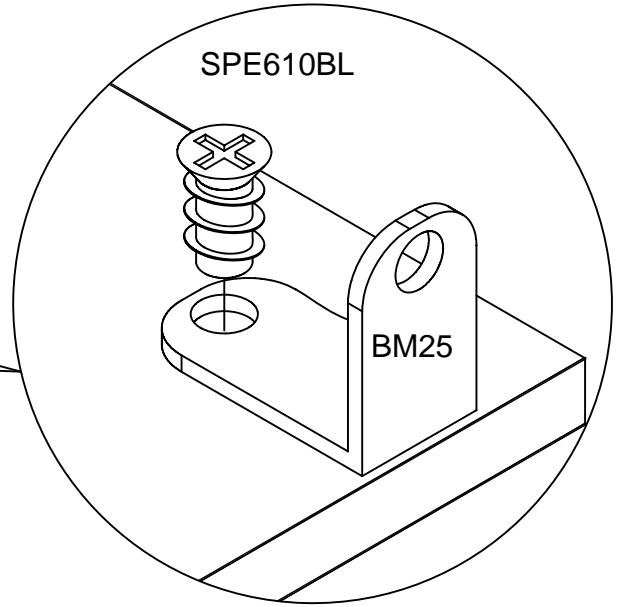
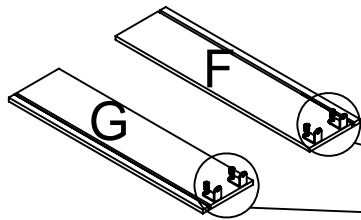

Note: Once parts (F and G) have been attached to part (H) with the euro screws, a total of four each. Then slide in the bottom part of the drawer (Part I).

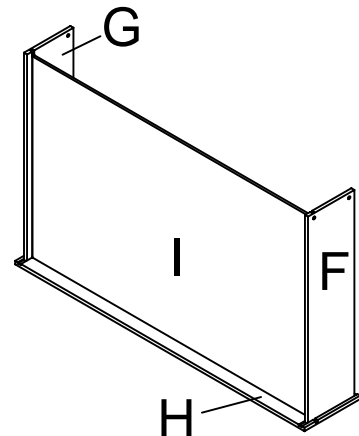
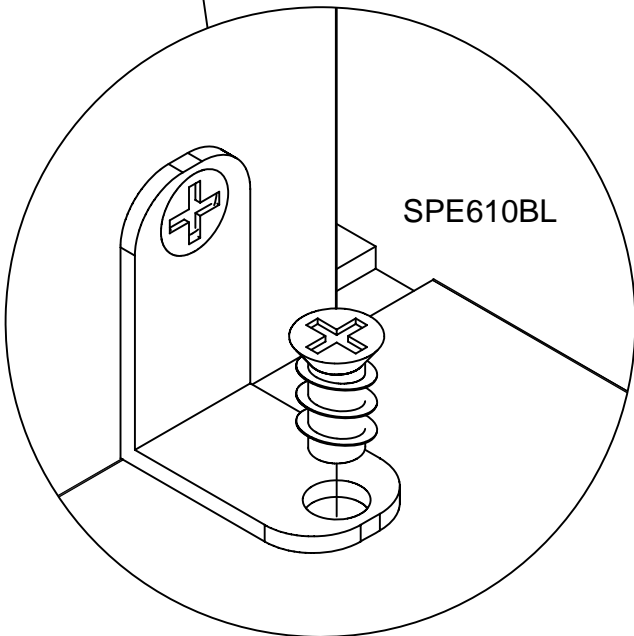

5

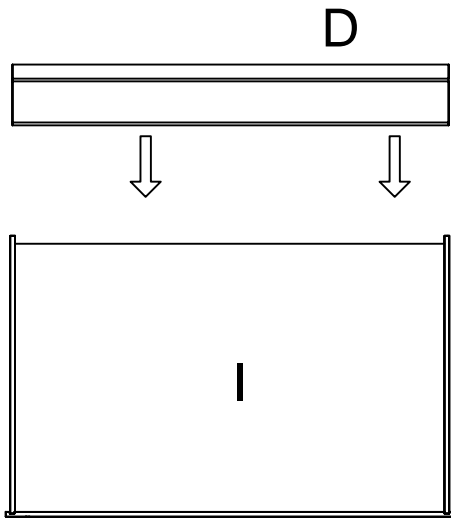

Note: Place (D) onto (in between) Drawer Sides (F) and (G). Repeat last steps for the rest of the drawers.

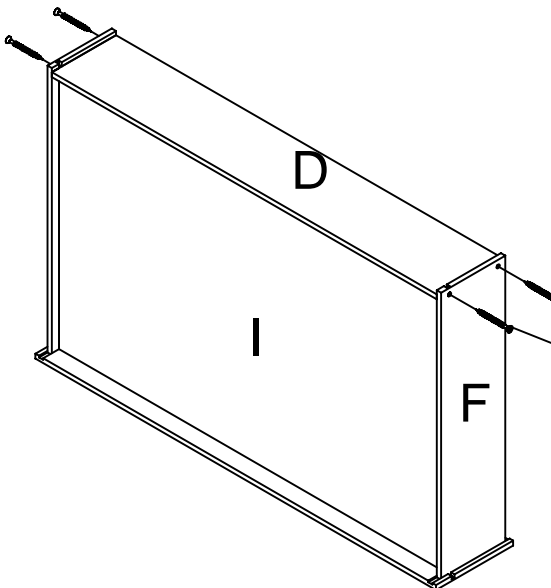

Note: Attach part (D) with two screws on both sides (Parts F & G) a total of four screws as shown below.

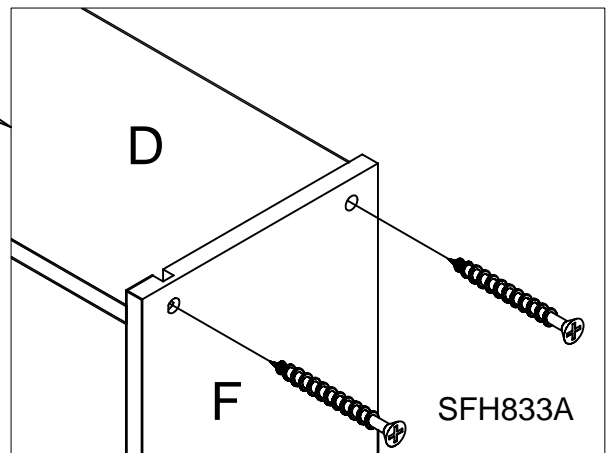

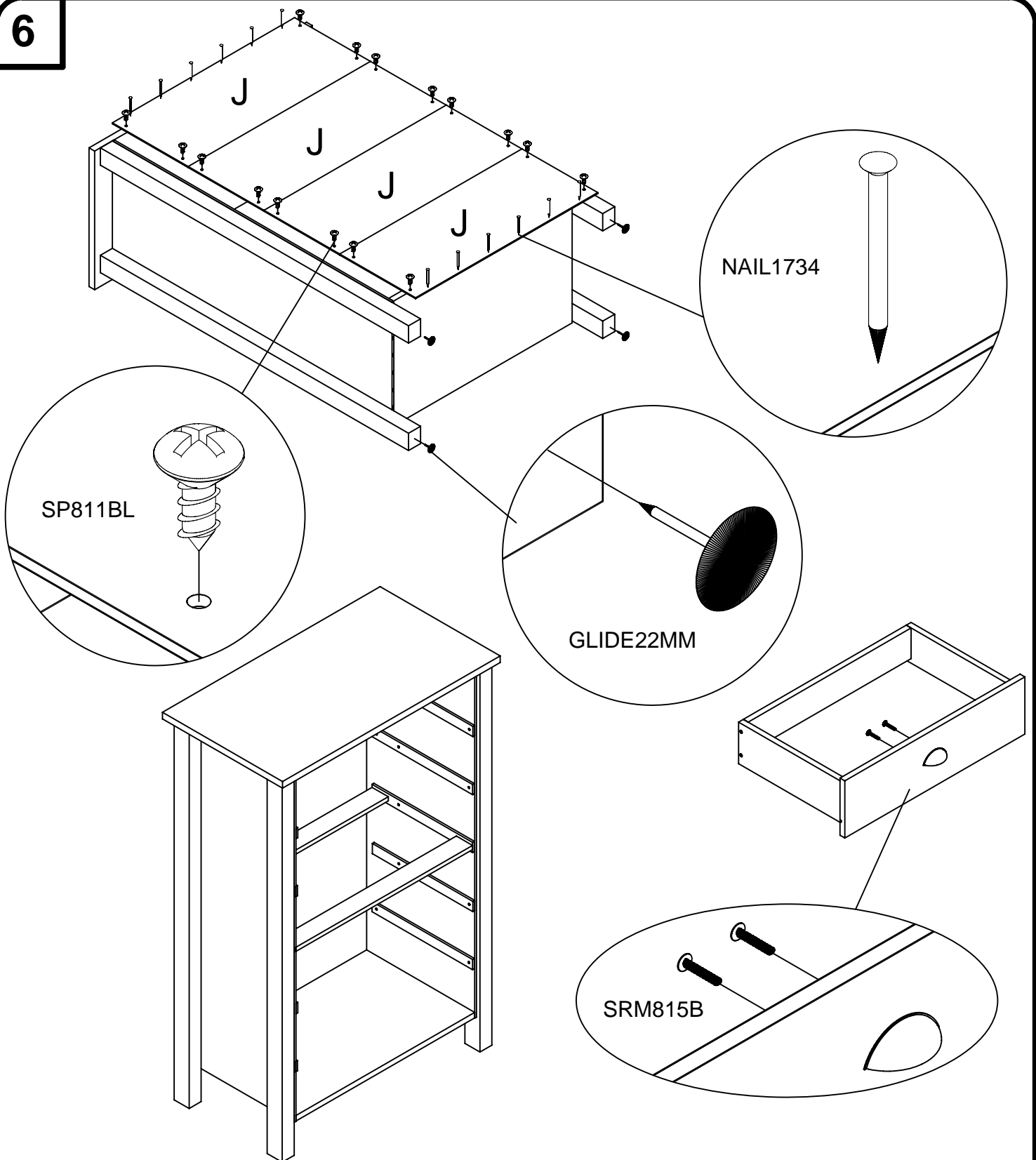
6

Place the unit face down. Align the Back Panel (J) over the of the unit. Make sure the assembly is square and leave equal amount of margin all around. Secure the panels by screwing 4 screws through the pre-drilled holes for all panels (2 screws on both ends). Next, nail the top and bottom (as shown above) with approximately 4" spacing between the nails. Make sure to keep the nails centered on the edges to avoid splitting of the boards.

7

Note: Insert the drawers by following the diagram below. Start from the bottom and work your way up. This way you can have a clear view where to insert the next drawer.

