



IF PARTS ARE MISSING AND OR DEFECTIVE, IF INSTRUCTIONS ARE NOT CLEAR
OR IF YOU ARE EXPERIENCING PROBLEMS ASSEMBLING OUR PRODUCT.







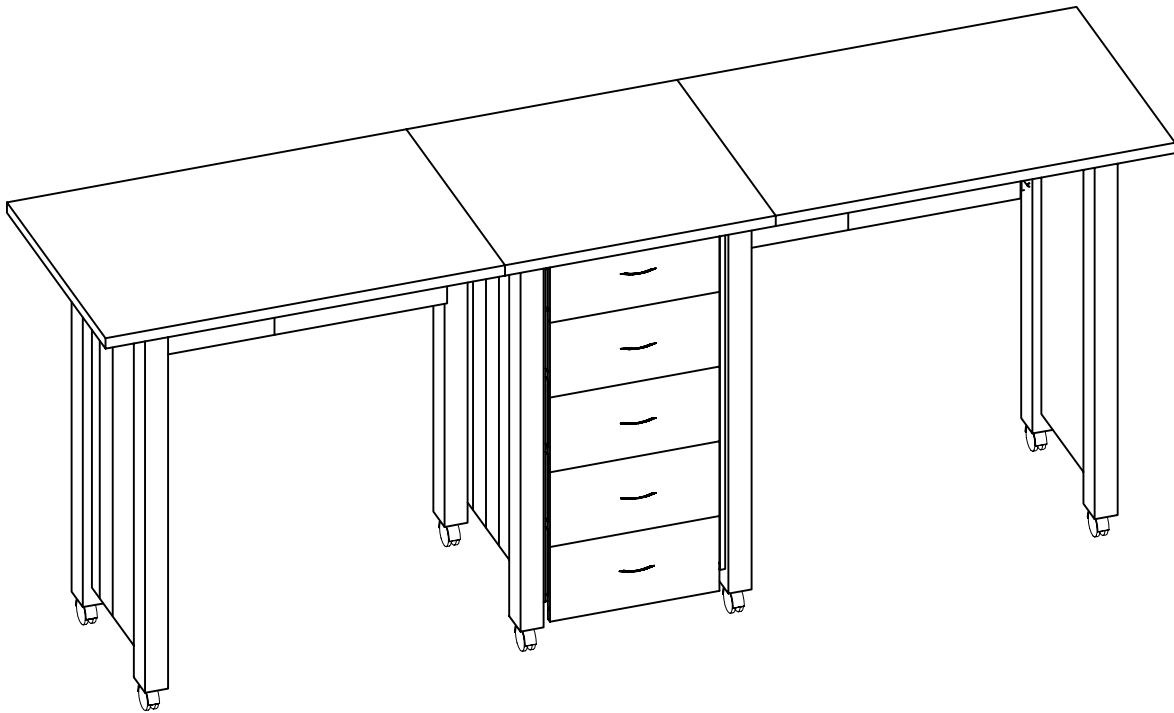



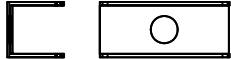

**BEFORE YOU RETURN THE PRODUCT TO THE STORE,
PLEASE CALL US TOLL FREE FOR CUSTOMER SERVICE ASSISTANCE
(888) 777-8250**

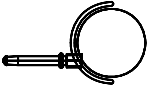
**OR SEND US EMAIL AT
help@spartakent.com**

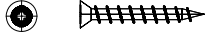
PLEASE HAVE ITEM NUMBER READY, AND A REPRESENTATIVE WILL GLADLY ASSIST YOU

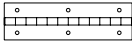

HARDWARE LIST

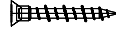
HARDWARE	PART NUMBER	DESCRIPTION	QTY
	CAMLT12	CAMLOCK	4
	CAMBTQF	QUICKFIT BOLT	4
	UCHAN12	U-CHANNEL	4
	SP12PR	PLASTIC ROLLER	4
	DOWW830	1- $\frac{1}{4}$ LONG WOOD DOWEL	4
	CAS40S	40mm CASTER W/STEM	8
	PUPL128--	HANDLE	5
	CAS40SIN	40mm CASTER W/STEM INSERT	8
	SF1025BL	WOOD SCREW	4
	SCXXS	SCREW COVER CAP	4
	GLUEWD	GLUE	2
		BLOCK	2
	SPB1016BL	PAN HEAD SCREW	34
	HIN152S	SHORT HINGE	10
	SFH612A	WOOD SCREW	12
	SFH833A	WOOD SCREW	28

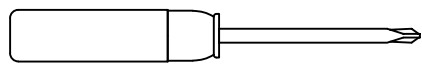

PHILLIPS SCREWDRIVER

TOOL REQUIRED

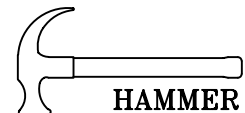

HAMMER

PARTS IDENTIFICATION

NOTE: FIRST MAKE SURE THAT YOU HAVE ALL OF THE PARTS LISTED ON THIS SHEET. IF YOU ARE MISSING ANY PIECE(S), DO NOT ASSEMBLE THE UNIT. INSTEAD, CALL CUSTOMER SERVICE NUMBER AT: (888) 777-8250. WE WILL BE HAPPY TO ASSIST YOU.

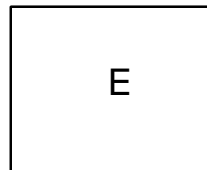
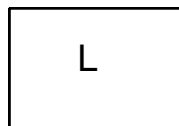
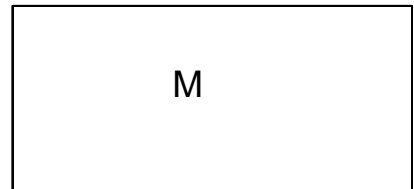
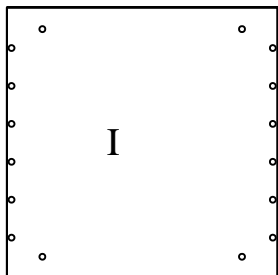
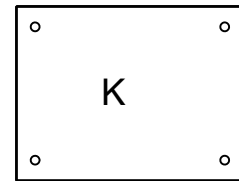
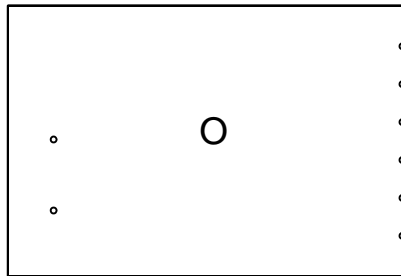
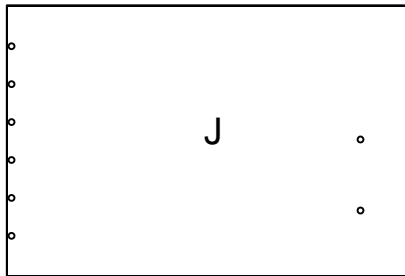
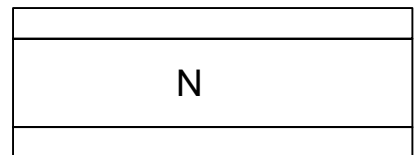
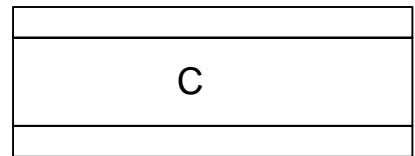
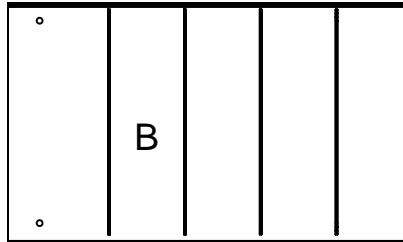
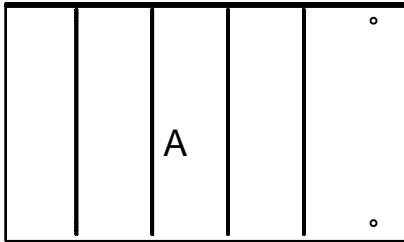

1017A-Left Side 1pc
 1019B-Right Side 1pc
 1017C-Sliding side left 1pc
 1017D-Drawer back 5pcs
 1017E-Drawer bottom 5pcs
 1017F-Dr. Sides & Front 5pcs
 1017G-Rail 8pcs

1019I-Top 1pc
 1017J-Extension Left 1pc
 1017K-Bottom 1pc
 1017L-Brace 4pc
 1017M-Back Panel 1pc
 1019N-Sliding Side Right 1pc
 1019O-Extension Right 1pc

PARTS ARE USUALLY MARKED ON THE RAW EDGE.

1

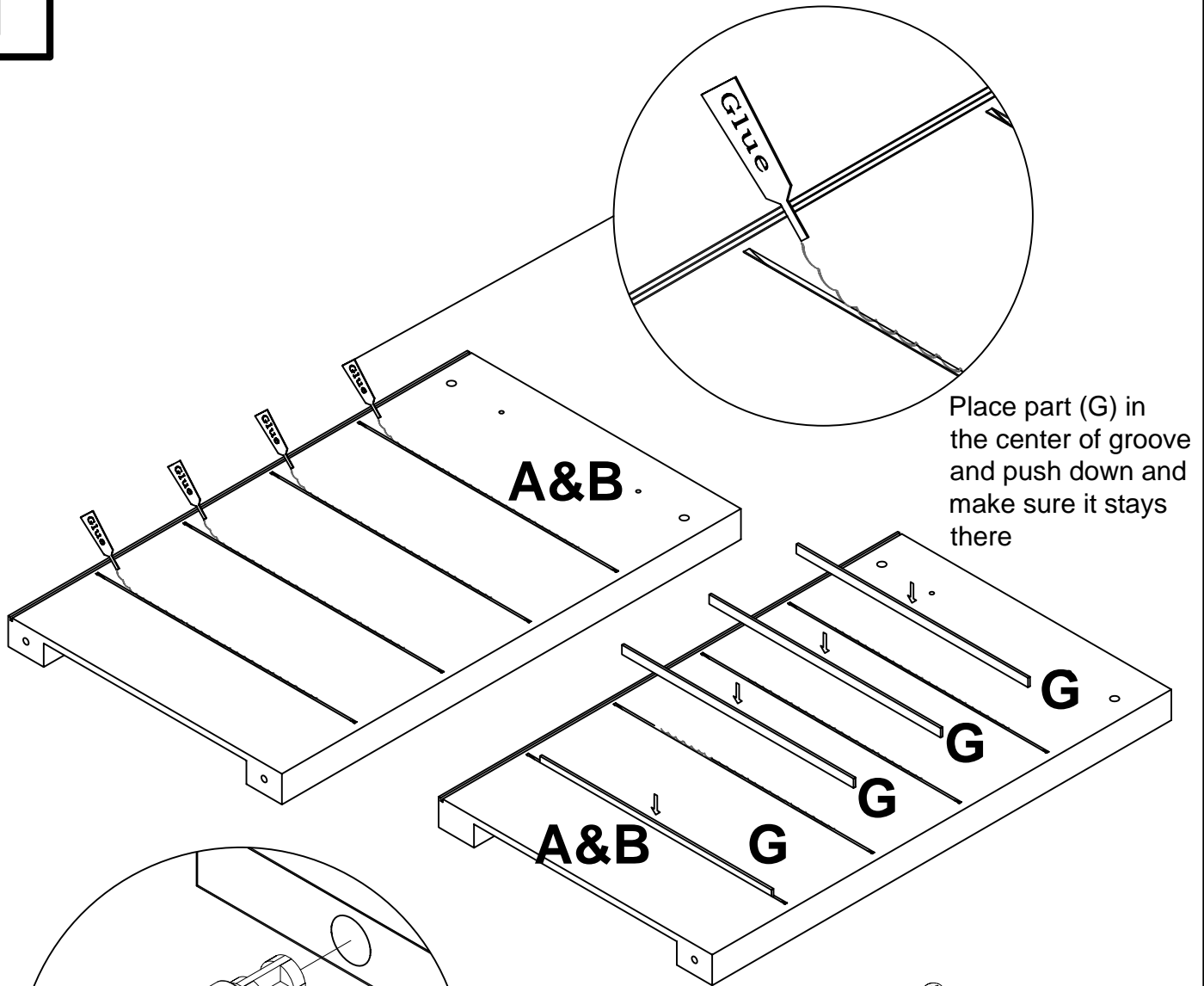

Place part (G) in the center of groove and push down and make sure it stays there

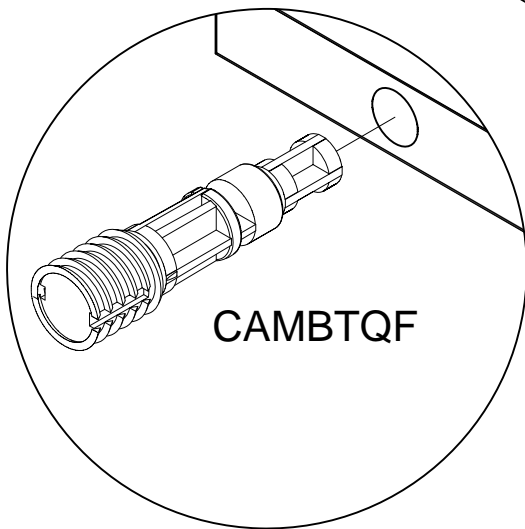

CAMBTQF

Leave parts (A&B) on the floor to allow the glue to set for at least 30 minutes. In the mean time you can assemble the drawers.

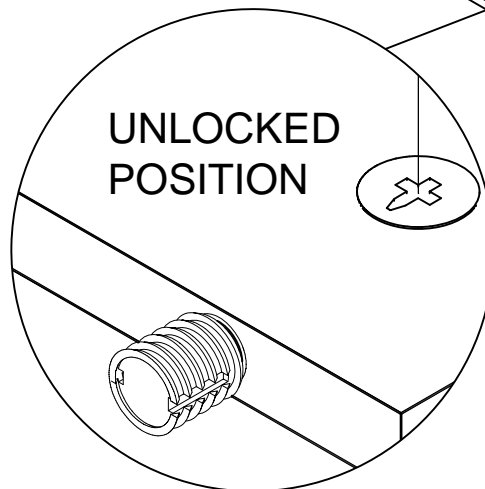

UNLOCKED POSITION

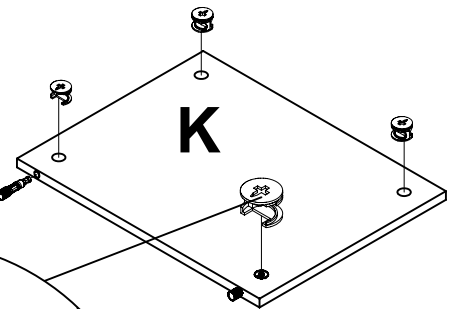

K

2

We recommend you do one drawer at the time.

The excess of glue can be wiped off with a damp cloth. Also, once glue sets it will turn translucent and it will not stick to laminated surface and can be easily peeled off.

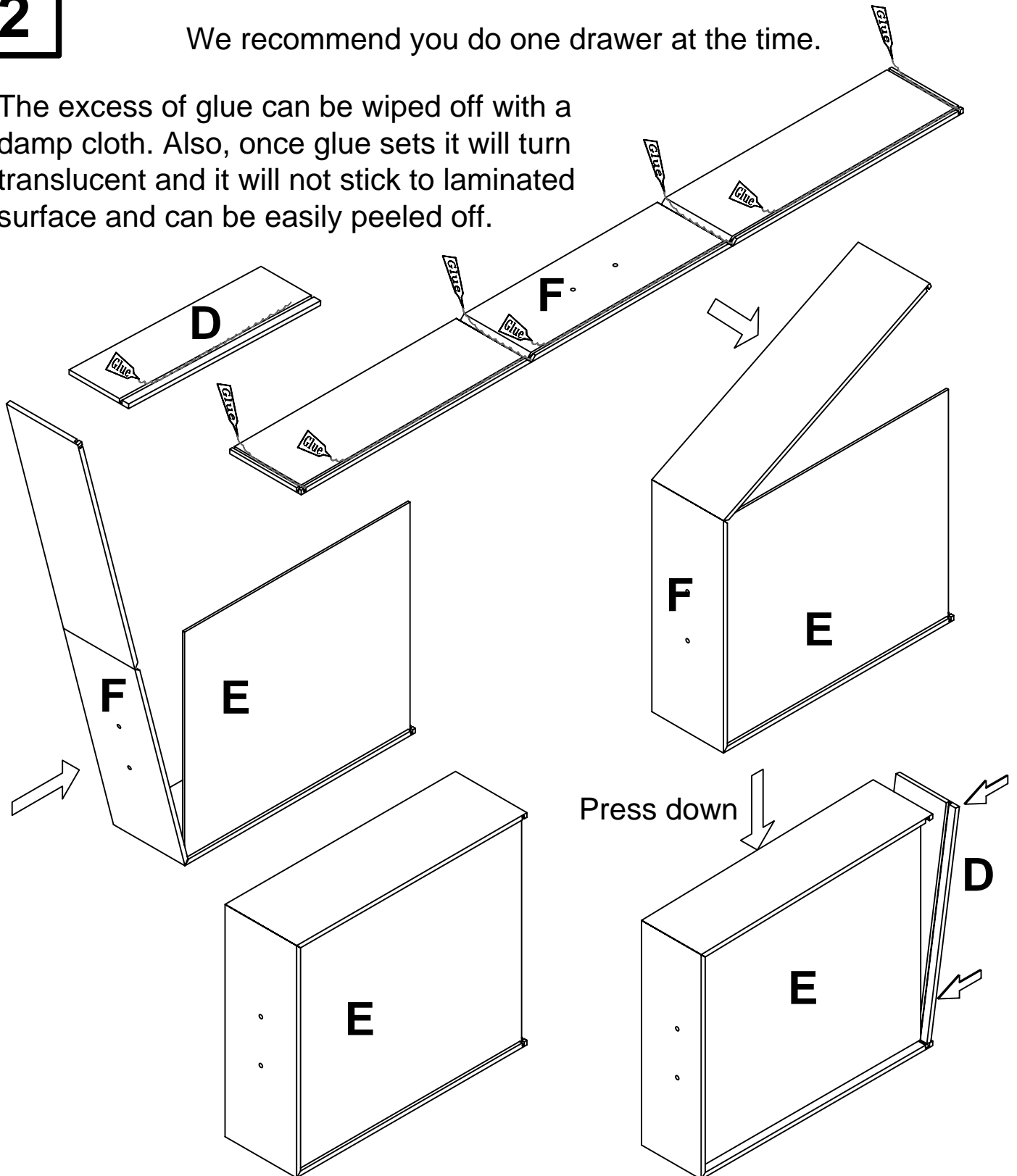

Allow glue to set at least for 2 hours. Repeat this step for the other four drawers. Make sure drawer back fits snug and there are no gaps. Leave drawers on their side until glue has set. You may put weight on it, like couple of books to apply pressure. In the mean time you can complete assembly of the frame of the workstation.

3

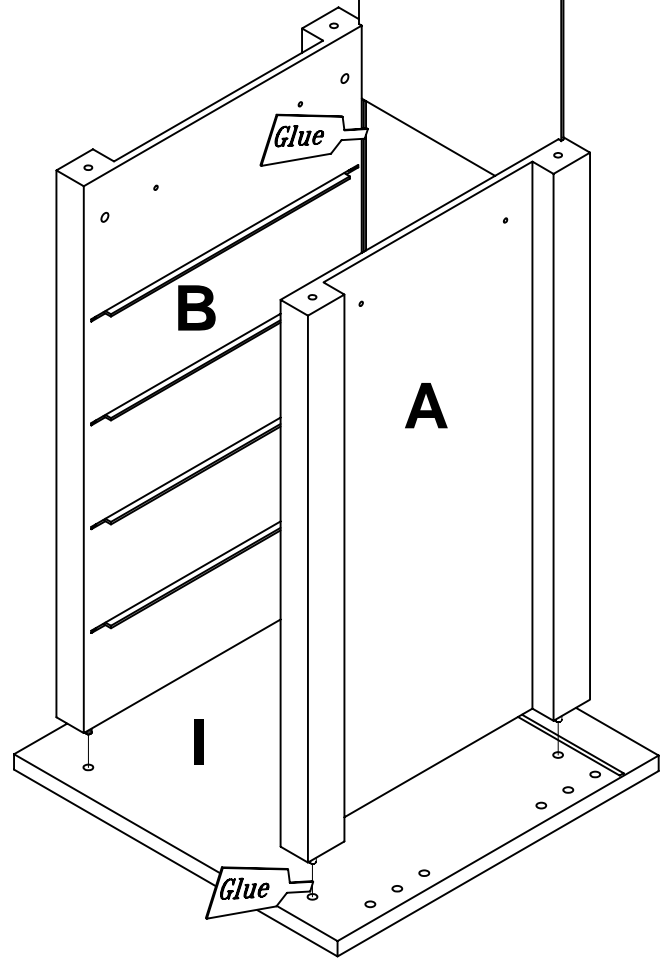
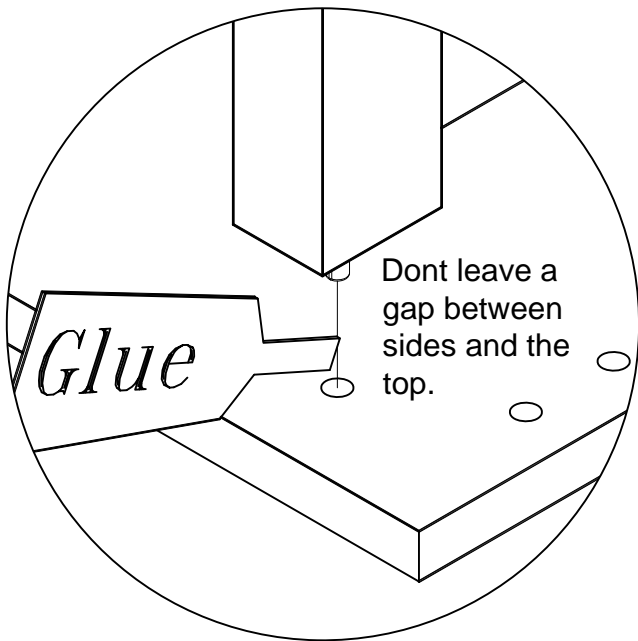
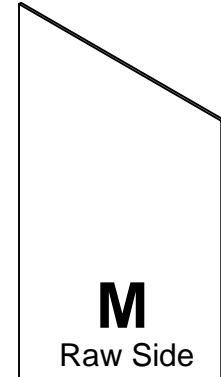
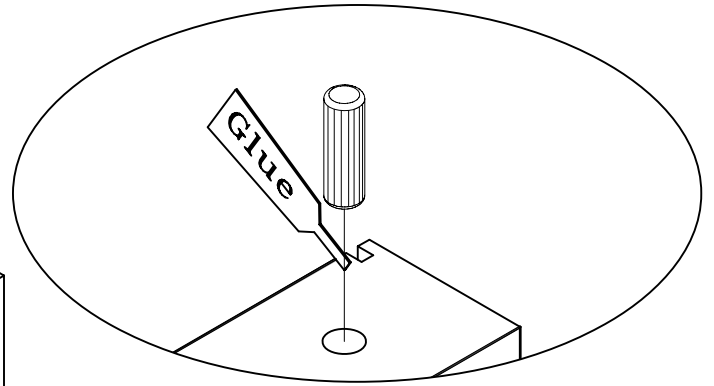
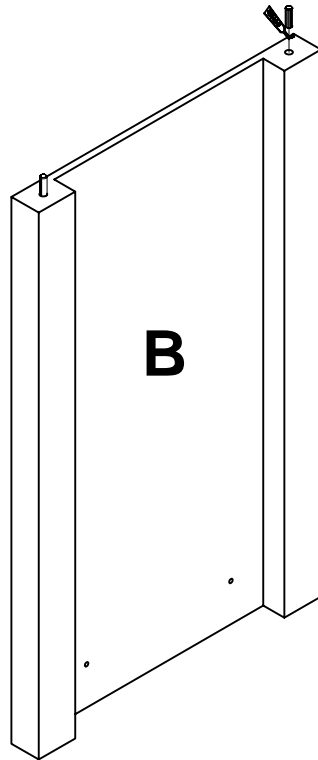
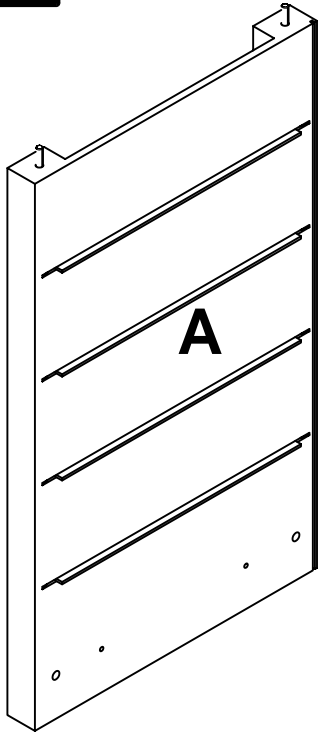

4

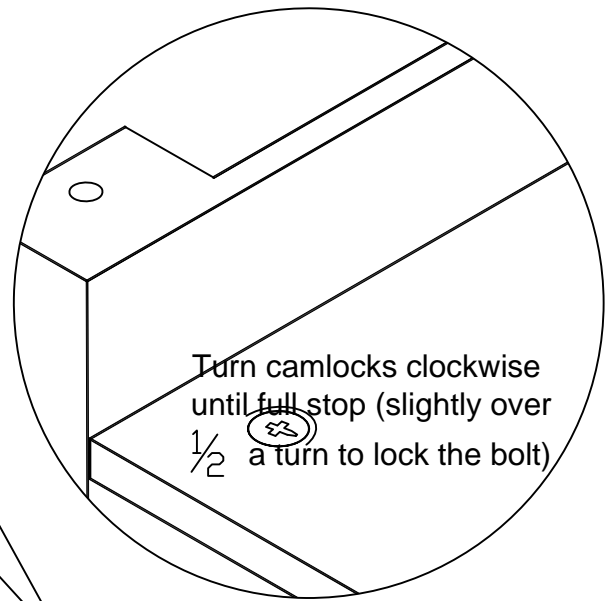
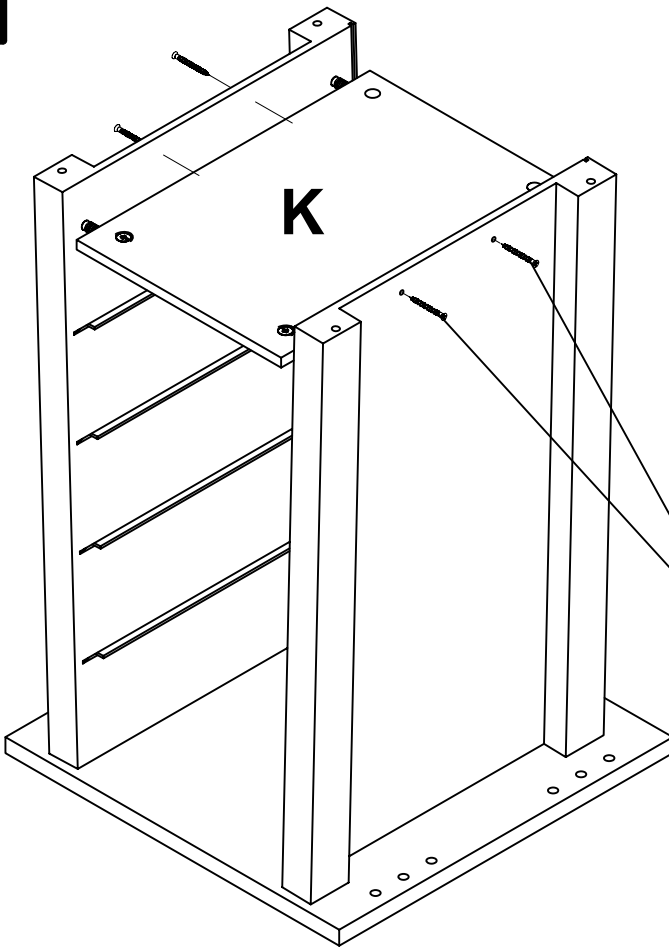

Screw cover
cap 4 locations

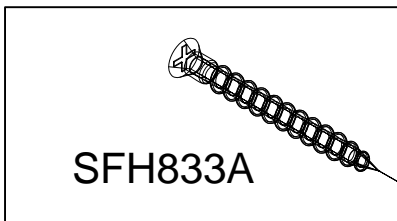
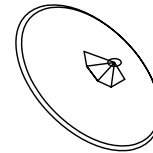

SFH833A

1. Insert part (K) onto part (A) then open the unit as much as you need to fit the part (K).

2. Push the sides (A&B) together. Make sure leave no gap between parts.

3. Lock camlocks by turning clockwise until full stop (slightly over $\frac{1}{2}$ a turn to lock the bolt).

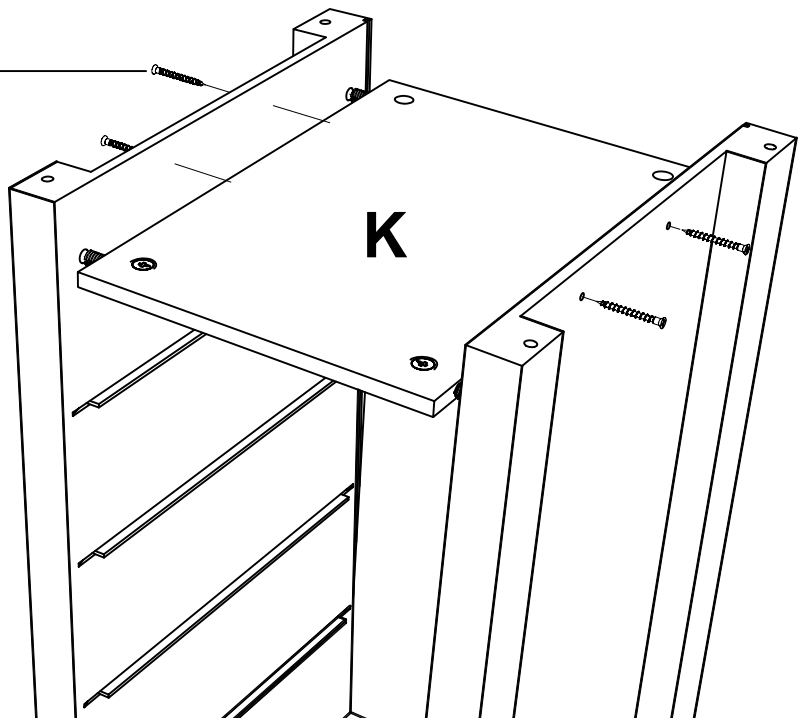

5

Use block provided in hardware kit.

Locking casters install in the front.

Tap in plastic inserts in first.

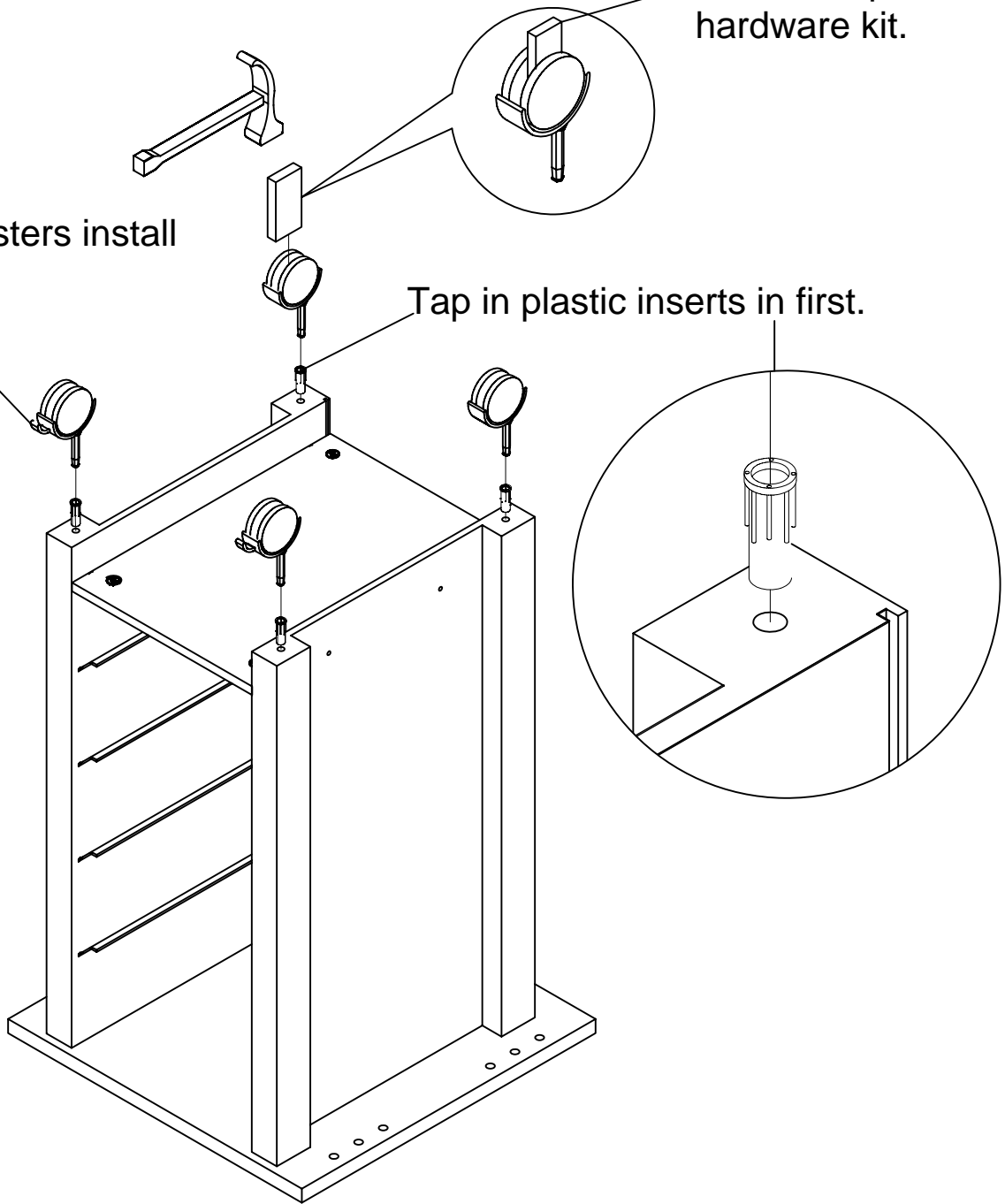

6

Do not over tighten the screws as you may strip the wood. It will be a good idea not to use power drill.

Place flat side of plastic spacer on the board and insert screw on recessed side.

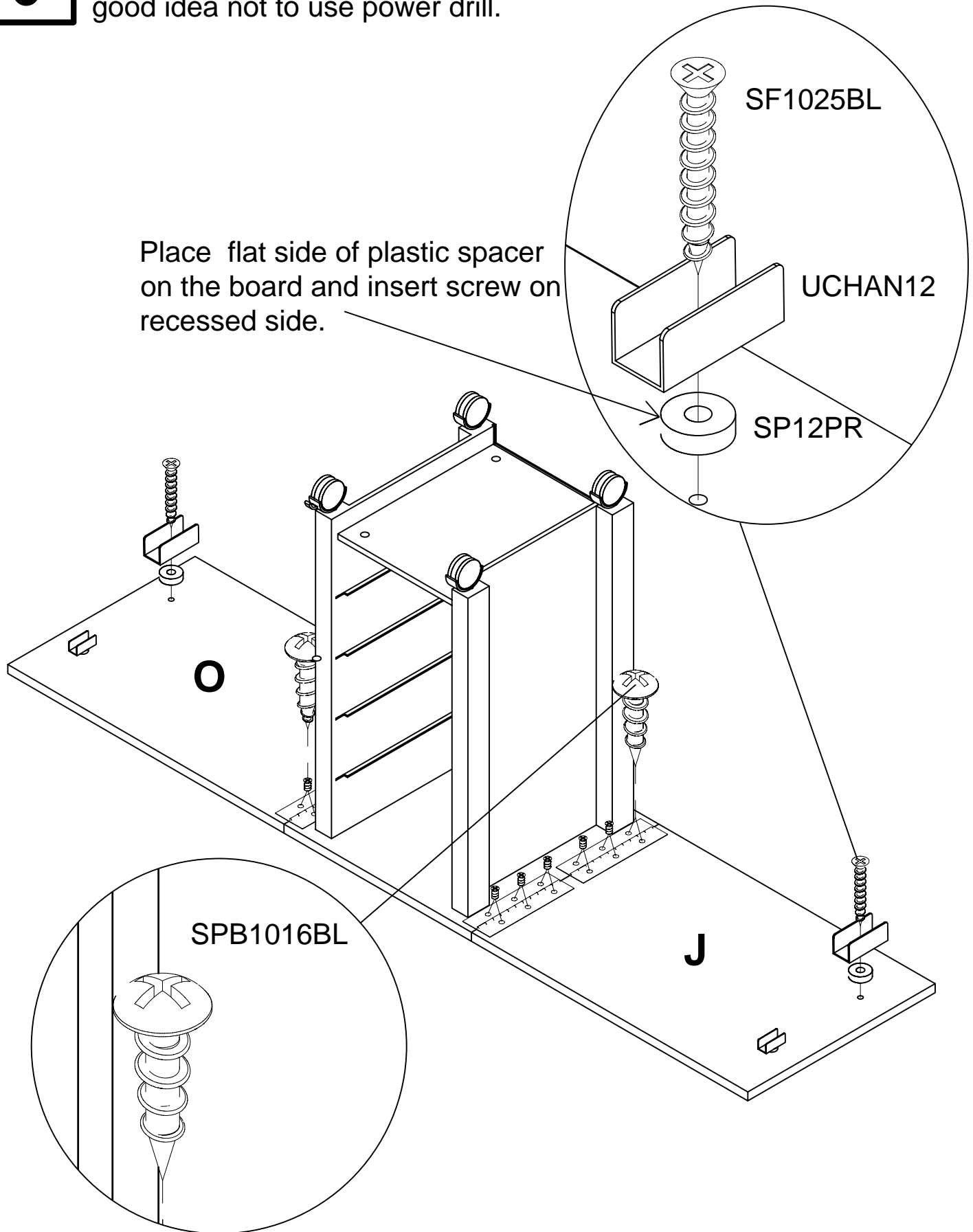

7

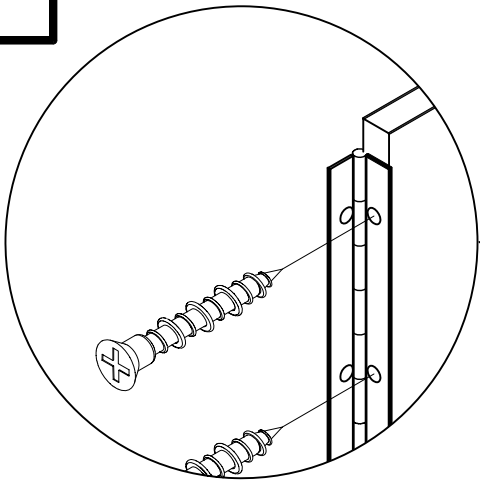

Raw Edge

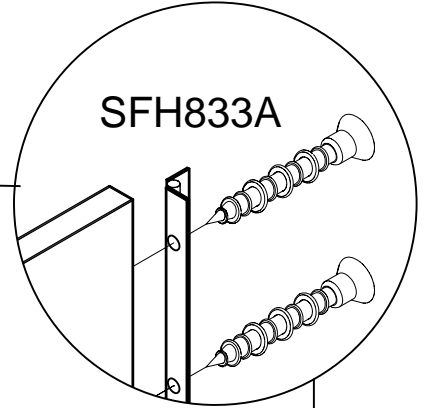
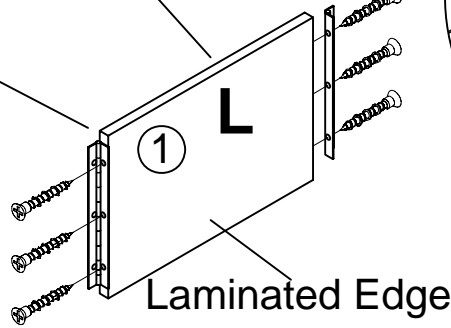

SFH833A

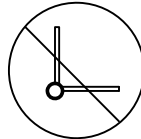

NO

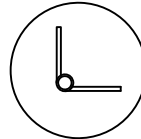

YES

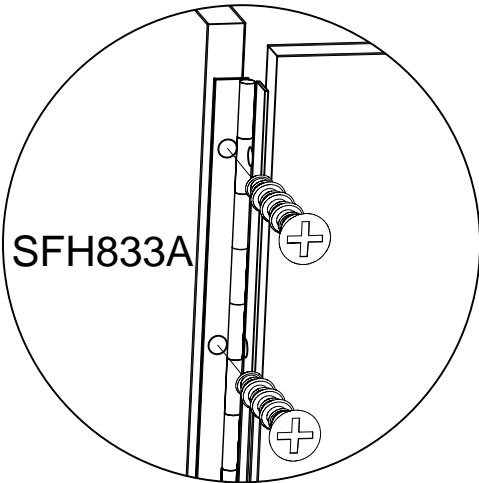
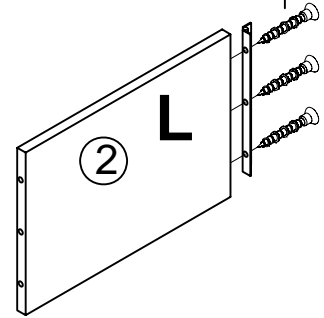

SFH833A

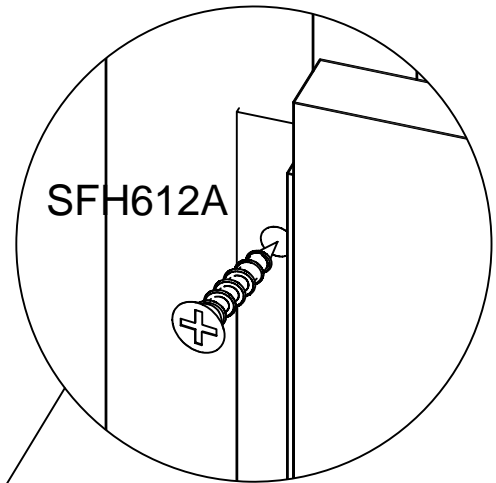

SFH612A

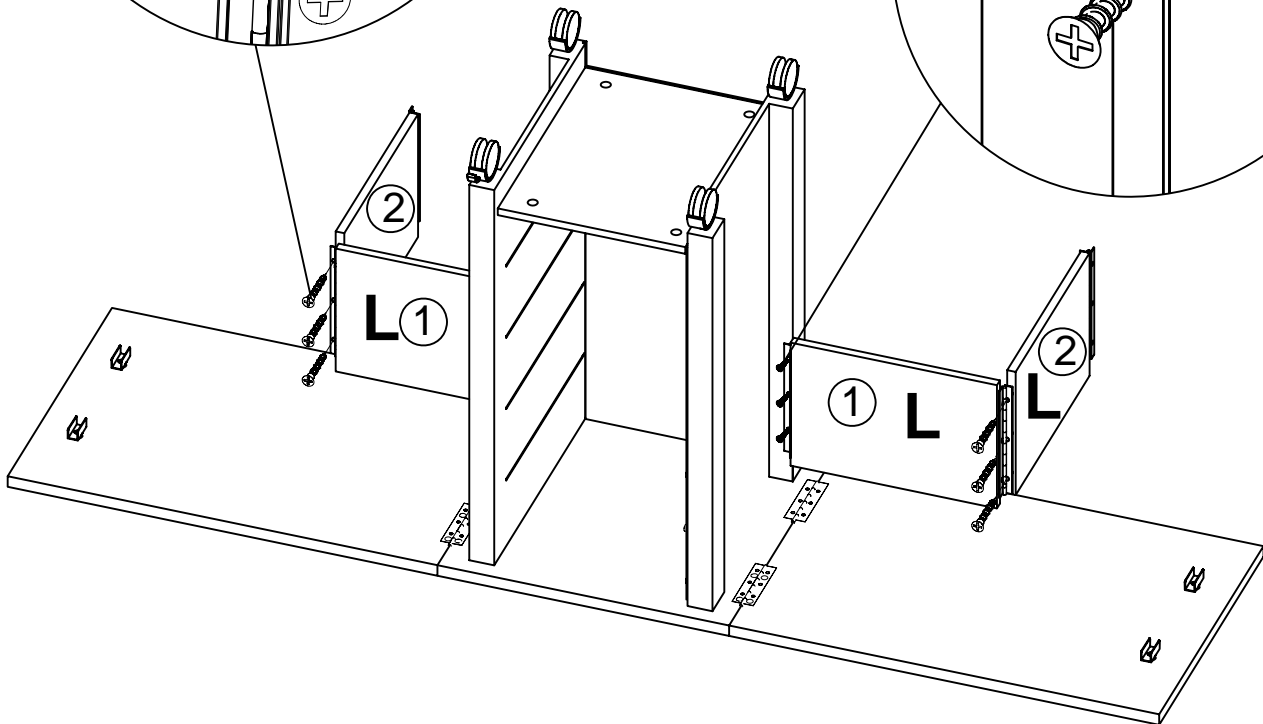

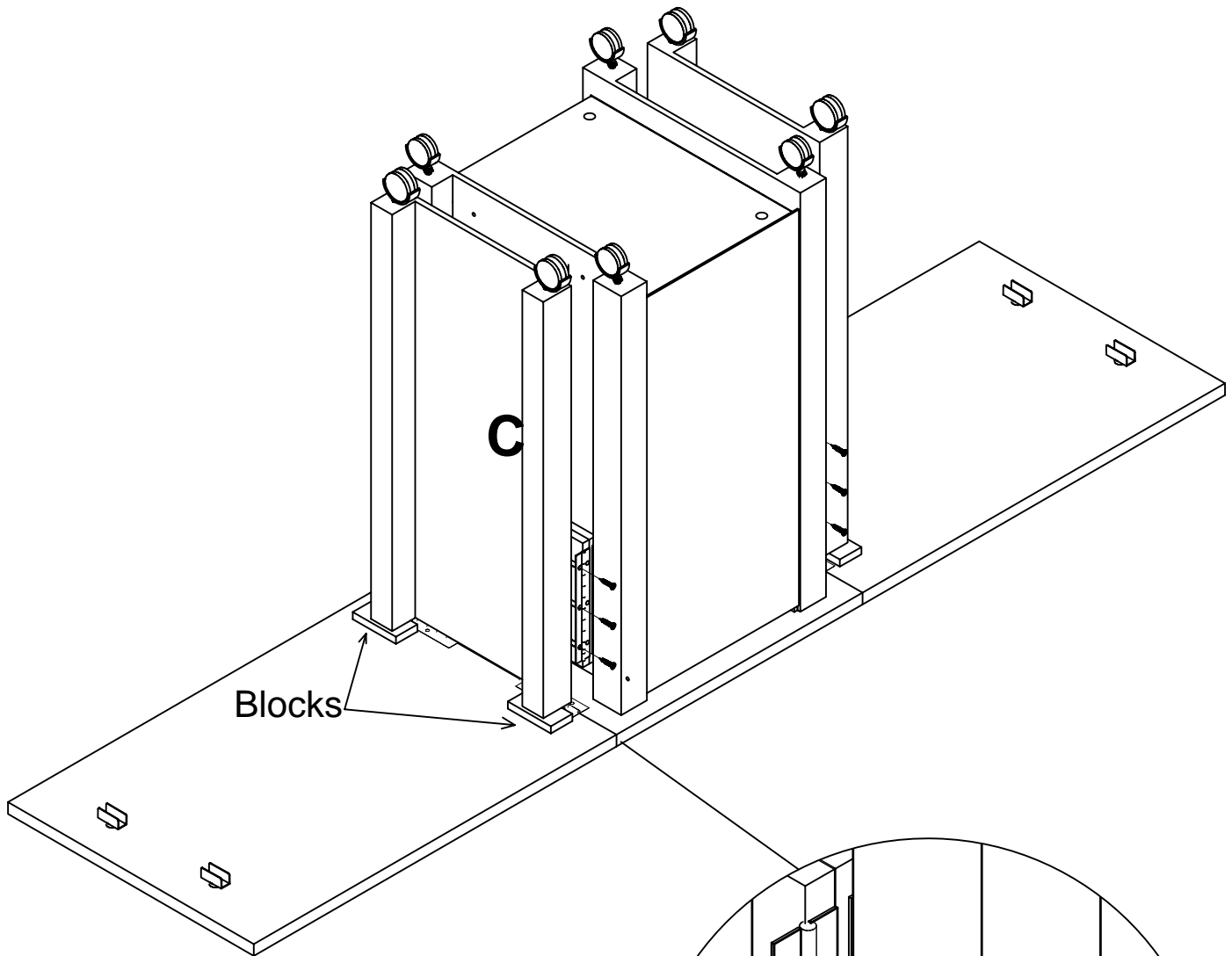

Blocks

Use two blocks provided in hardware kit to support mobile panel while connecting part (C) to part (L) with the hinge..

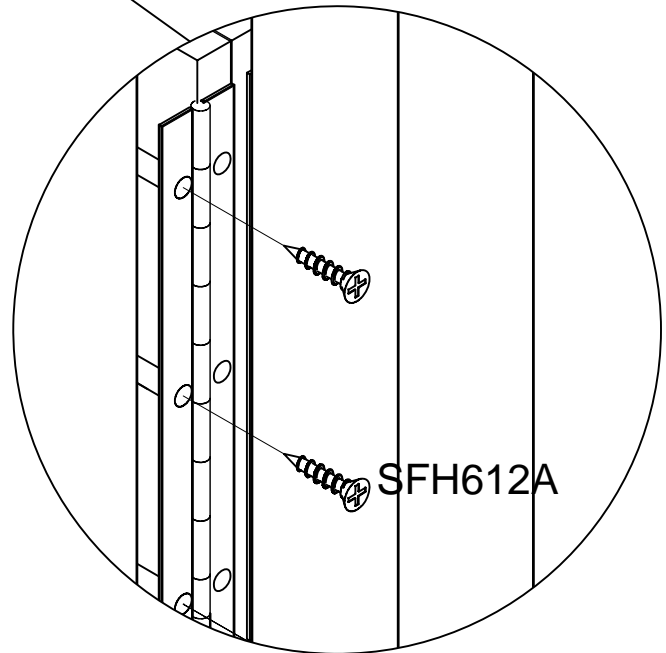

SFH612A

9

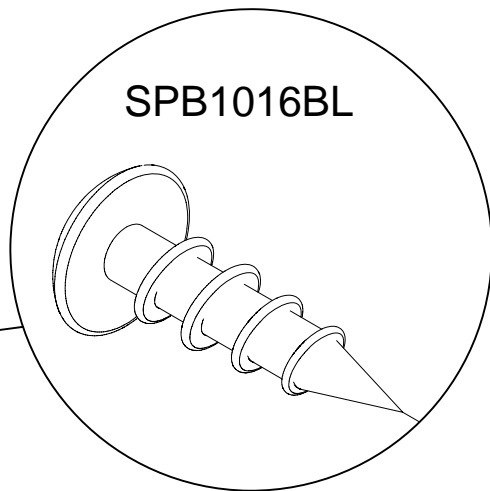
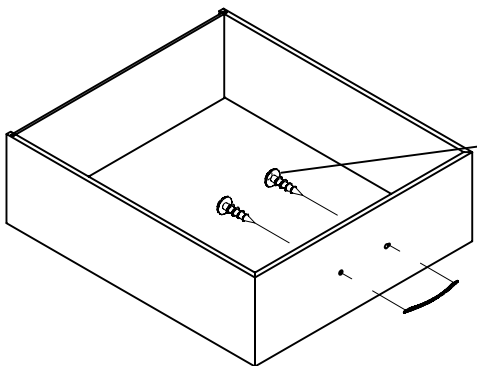
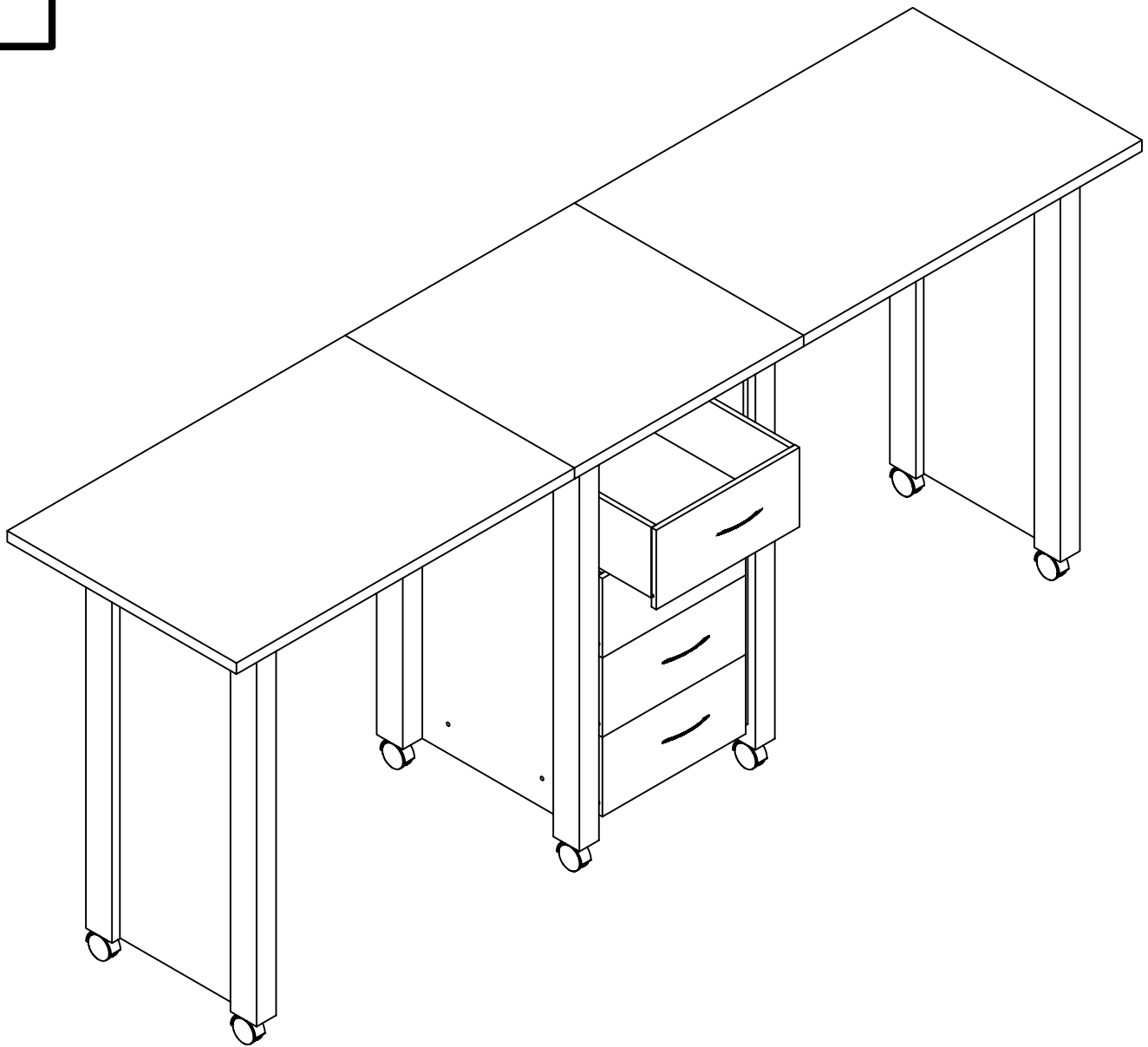

TRANSFORMATION INSTRUCTIONS

First, lift the top panel slightly.
(NOTE: Lift just enough so that the boards will not get damaged).

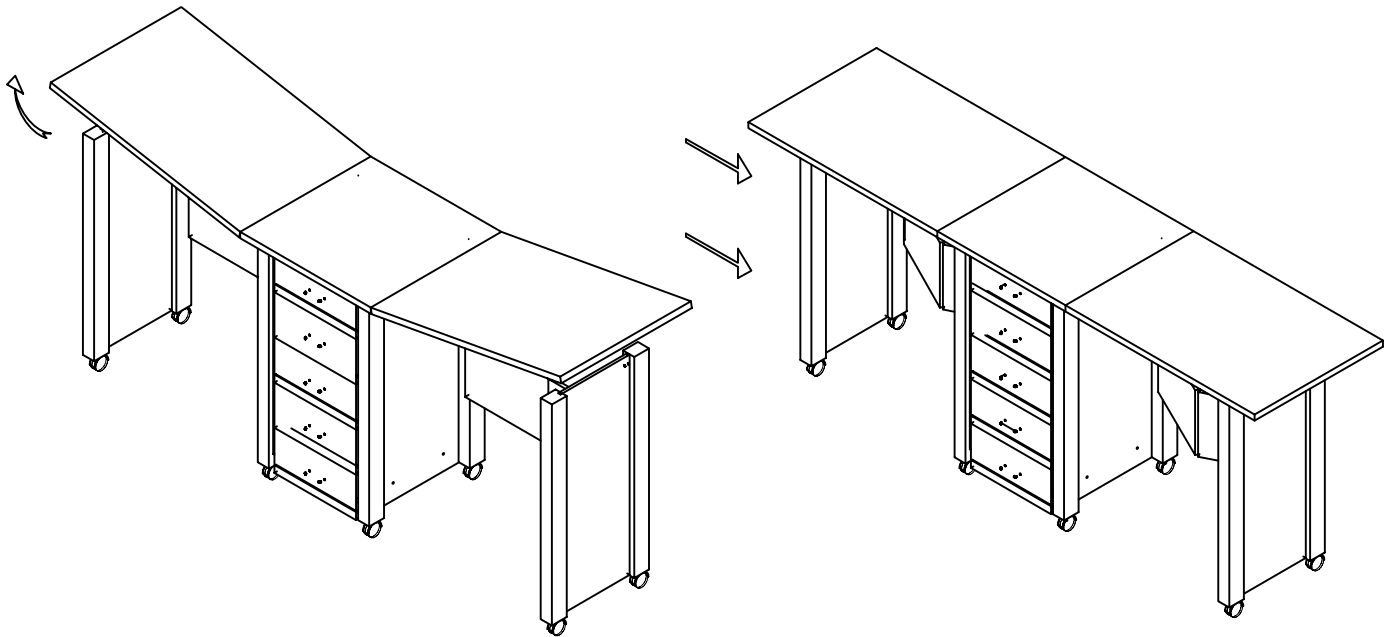

Next, push the side panel in.
Make sure you push it in as far as it will go.

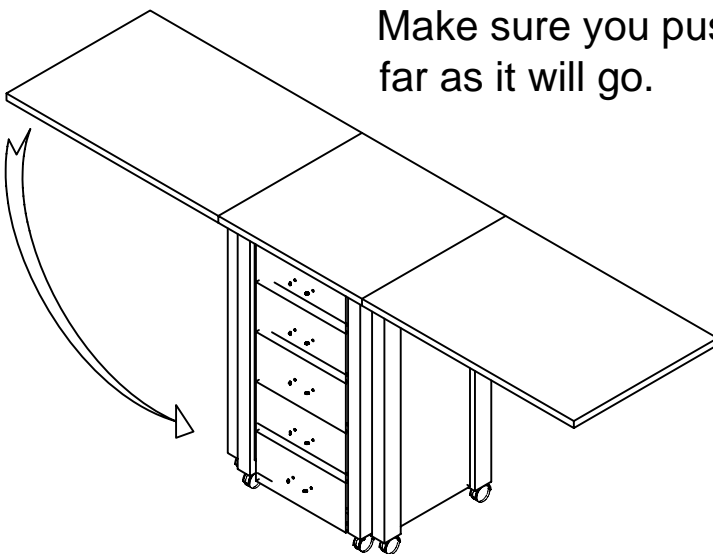

Finally, gently let the top panel down.

The U-channel #UCHAN12 clamps onto the side wall of part C between the square posts. It is not intended to fit into the cavities on the posts Part C.

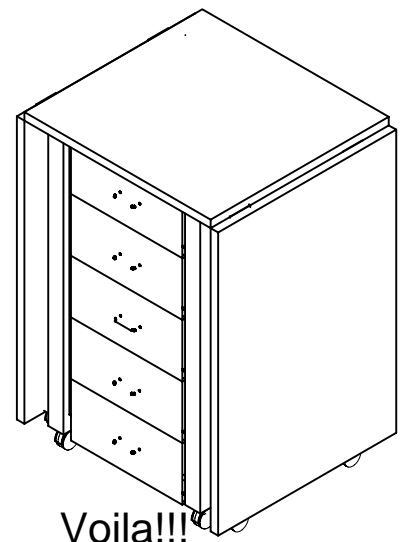

Voila!!!