

**SELECTRONIC™ FloWise®
DUAL FLUSH TOILET FLUSH VALVE
BATTERY POWERED, SENSOR OPERATED, 1.6/1.1 GPF**



GENERAL DESCRIPTION:

Exposed, Battery Powered, Sensor Operated Selectronic™ Dual Flush Water Closet Flush Valve for floor-mounted or wall-hung 1-1/2" top spud bowls.

Inlet includes 1" I.P.S. angle stop with back-flow protection, vandal-resistant cap, sweat solder kit, cover tube and wall flange.

Outlet includes 1-1/2" vacuum breaker with adjustable tailpiece, spud coupling and flange.

PRODUCT FEATURES:

- Light flush (1.1 gpf: 30% water savings) if user is in detection zone for 60 seconds or less
- Standard flush (1.6 gpf) if user is in detection zone for more than 60 seconds
- Electronic flush valve with Selectronic™ proximity system for "Hands Free" operation
- Self-Cleaning Piston with integral wiper spring prevents clogging and reduces maintenance
- Piston operation delivers superior flush accuracy and repeatability
- Fully mechanical Manual Override Button can operate for an unlimited time without power
- Valve remains closed and does not need to be reset after loss of power or water pressure
- Sanitary Flush: Valve automatically flushes after 24 hours of non-use to clean fixture & maintain trap seal
- Sensor & electronic controls are fully enclosed and water resistant
- Range can be adjusted manually or with optional remote control
- Chemical resistant EPDM seals are unaffected by chloramines & other chemicals
- Adjustable tailpiece
- Factory-installed CR-P2 lithium battery included
- No external volume adjustment
- Can be installed left or right-handed

MODEL NUMBER:

- ❑ **6065.761.002** Dual Flush Toilet Flush Valve for 11-1/2" Supply C\L to top of bowl, 1.6/1.1 gpf
- ❑ **6065.762.002** Dual Flush Toilet Flush Valve for 27" Supply C\L to top of bowl, 1.6/1.1 gpf
- ❑ **6065.561.002** Dual Flush Retrofit for Existing Flush Valves, 1.6/1.1 gpf. Replaces industry standard manual and electronic valves. Does not include the vacuum breaker assembly, angle stop or sweat solder kit.

OPERATING PRESSURE:

Overall Range: 20-125 psi**

Recommended: 25 psi (flowing)-80 psi (static)

FLOW REQUIREMENT:

25gpm (94.6 L/min.)

** Water pressure over 80 psi is not recommended for most plumbing fixtures.

BATTERY LIFE:

200,000 cycles (4 years @ 4000 cycles per month)

ACCESSORIES:

- Cast wall flanges (1" & 1-1/2")
- Solid ring pipe supports (2-1/2" & 6" C-E)
- Split ring pipe supports (2-1/2" & 6" C-E)

**TYPICAL WATER CLOSET INSTALLATION:
AFWALL™ TOILET SHOWN**

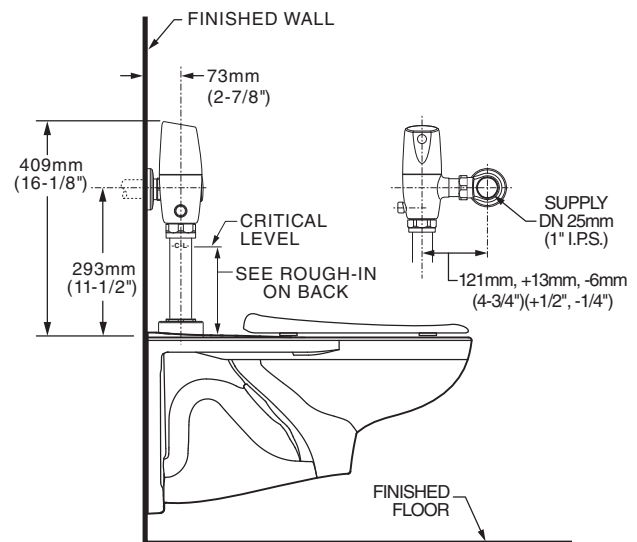

RECOMMENDED SPECIFICATION:

Electronic proximity infrared sensor activated toilet flush valve shall feature self-cleaning piston valve with integral wiper spring in refill orifice to prevent clogging. Includes a fully mechanical manual over-ride that can provide a complete flush without battery power. Includes cast brass valve body and metal cover with chrome finish, vandal resistant stop cap and lithium battery. Angle stop with back-flow protection and vacuum breaker included. Flush valve shall be American Standard Model # 6065.76_.002, 6065.561.002.

**SELECTRONIC™ FloWise®
DUAL FLUSH TOILET FLUSH VALVE
BATTERY POWERED, SENSOR OPERATED, 1.6/1.1 GPF**

LISTINGS:

- ASSE 1037
- ANSI/ASME A112.19.2
- ADA Compliant

Roughing-in Dimensions

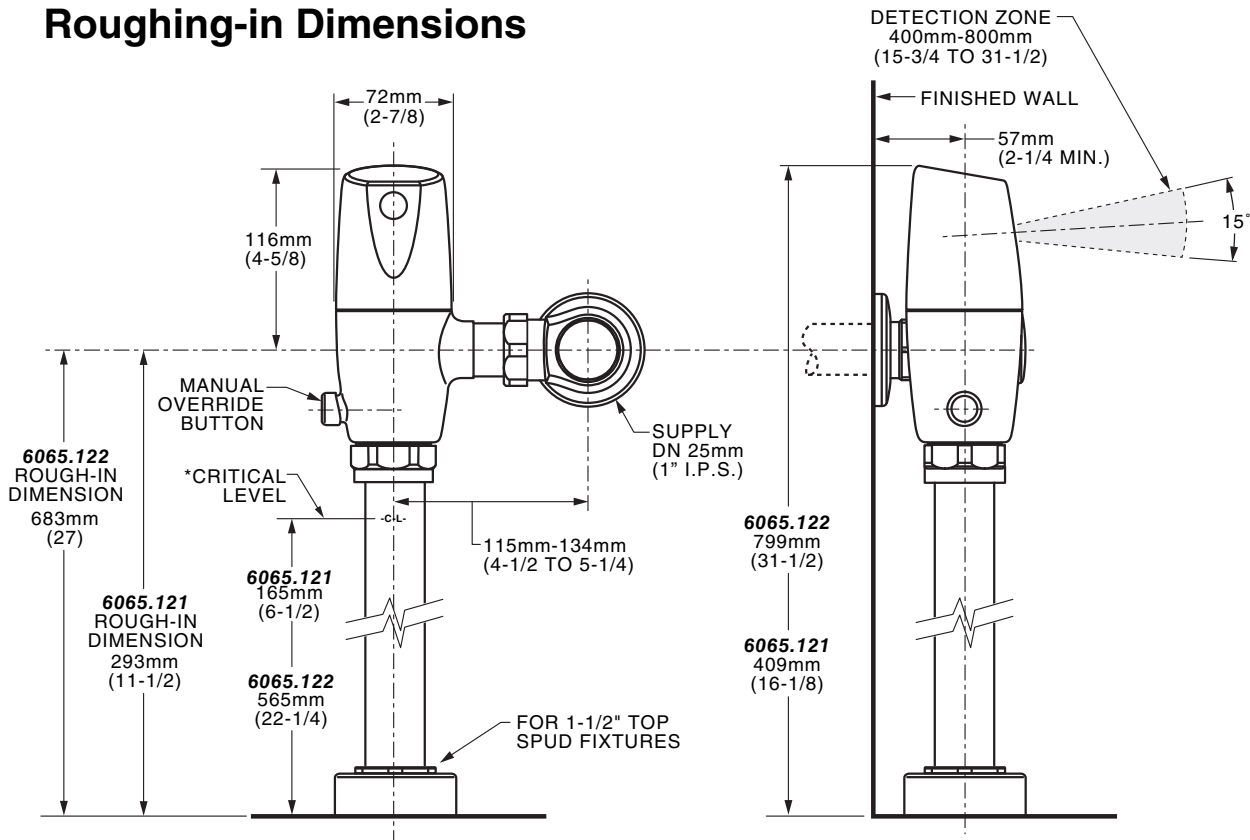

*Note: The Critical Line (-C-L-) on Vacuum Breaker must typically be 6" (152mm) above fixture. Consult Codes for details.

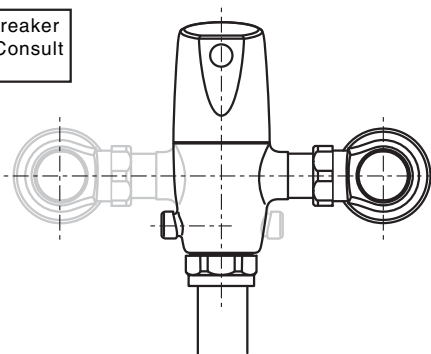

Right or Left Hand Installation

This flushometer valve is intended to be used with listed/certified 1.6 gpf/1.1 gpf dual flush bowls only.

 MEETS THE AMERICANS WITH DISABILITIES ACT GUIDELINES AND ANSI A117.1 REQUIREMENTS FOR ACCESSIBLE AND USABLE BUILDING FACILITIES-CHECK LOCAL CODES