

Installation Instructions

SELECTRONIC™ PROXIMITY TOILET CONCEALED FLUSH VALVE 1.28 & 1.6 GPF

MODEL NUMBERS

6065.32X 6065.36X

6067.32X 6067.36X

6068.32X 6068.36X

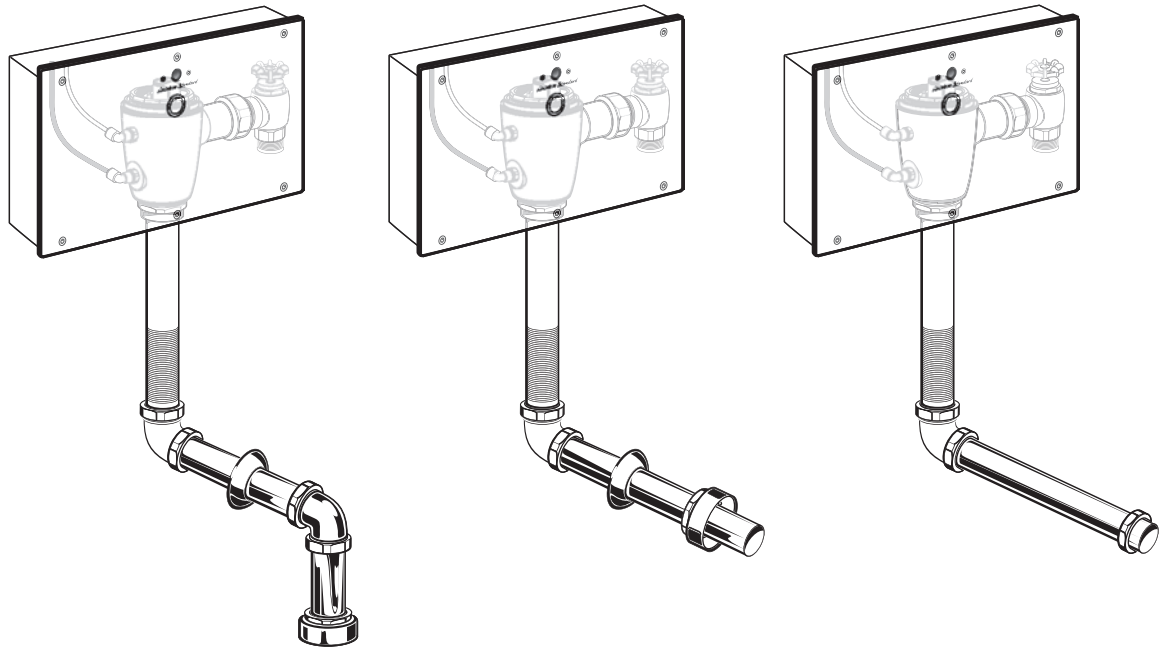

Concealed Flushometer for 1-1/2" Top or Back Spud Bowls

CLOG RESISTANT

- Self-cleaning piston valve prevents clogging and reduces maintenance.

ONE SENSOR FITS ALL

- Only 1 sensor for entire Selectronic™ line of faucets, urinals, and flush valves.
- Range can be adjusted manually or with optional remote control.
- Sensor Features Low Battery Indicator.

Certified to comply with ASME A112.19.2M
© 2010 AS America, Inc.

M968560 REV. 1.5

American Standard

NOTE TO INSTALLER: Please give this manual to the customer after installation.

To learn more about American Standard Faucets visit our website at: www.americanstandard-us.com
or U.S. customer's e-mail us at: faucetsupport@americanstandard.com

For Parts, Service, Warranty or other Assistance,
please call **1-800-442-1902 (In Canada: 1-800-387-0369)**
(In Toronto Area only: 1-905-3061093)

Thank you for selecting American-Standard...the benchmark of fine quality for over 100 years. To ensure that your installation proceeds smoothly--please read these instructions carefully before you begin.

UNPACKING

All American Standard Products Are Water Tested At Our Factory. Some Residual Water May Remain In The Valve During Shipping.

1. Remove the Flush Valve items from the carton. The illustration below shows all items after they have been removed from the carton. Some items may be packaged partially assembled to other items.

- | | | |
|----------------------------|---|-------------------------------------|
| 1. Flush Valve Assembly | 7a. Vacuum Breaker Flush Connection (Wall-Mount Back Spud) | 8a. AC Power Supply [Model# 6067] |
| 2. Electrical Box | 7b. Vacuum Breaker Flush Connection (Floor-Mount Back Spud) | 8b. DC Power Supply |
| 3. Cover Plate with Sensor | 7c. Vacuum Breaker Flush Connection (Top Spud) | 8c. 10' Extension Wire for Multi-AC |
| 4. Supply Stop | | 9. Installation Instructions |
| 5. Sweat Solder Adapter | | 10. Wall Box |
| 6. Manual Override Hoses | | 11. Safety Chain |

CARE INSTRUCTIONS FOR CHROME PLATED ITEMS:

DO: SIMPLY RINSE THE PRODUCT CLEAN WITH CLEAR WATER. DRY WITH A SOFT COTTON FLANNEL CLOTH.

DO NOT: DO NOT CLEAN THE PRODUCT WITH SOAPS, ACID, POLISH, ABRASIVES, HARSH CLEANERS, OR A CLOTH WITH A COARSE SURFACE.

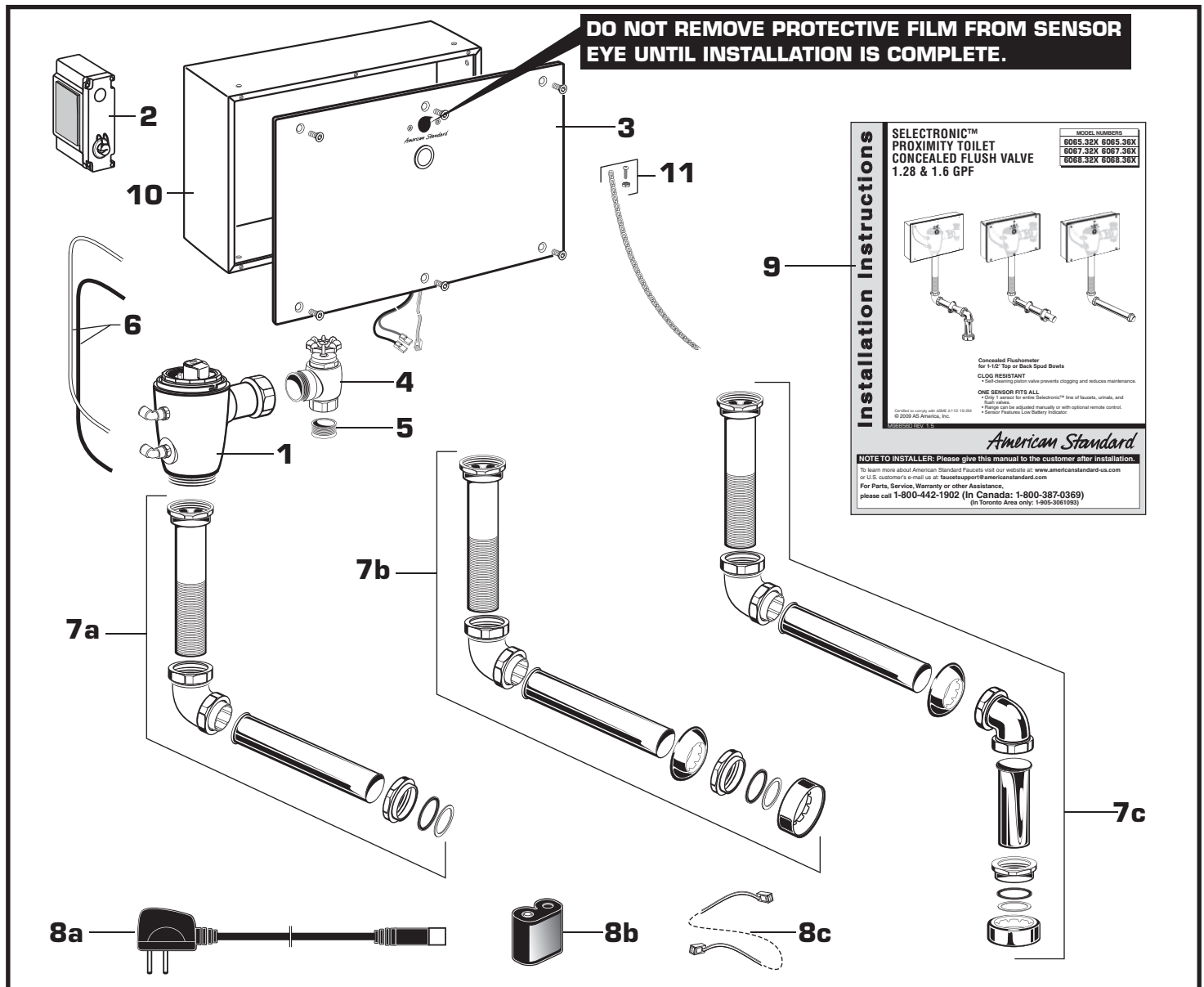

Fig. 1
Roughing-in Dimensions

GENERAL DESCRIPTION:

**SELECTRONIC™
PROXIMITY TOILET
FLUSH VALVE**

**Concealed Flushometer
for 1-1/2" Spud Fixtures**

Exclusive, self cleaning piston-type flush valve with proximity operation and manual override. Operates on DC (battery) or AC power. Recommended operating pressure 25 psi (flowing) to 80 psi (static). Can install left or right-handed. Detection Zone can also be adjusted manually, or with optional remote control.

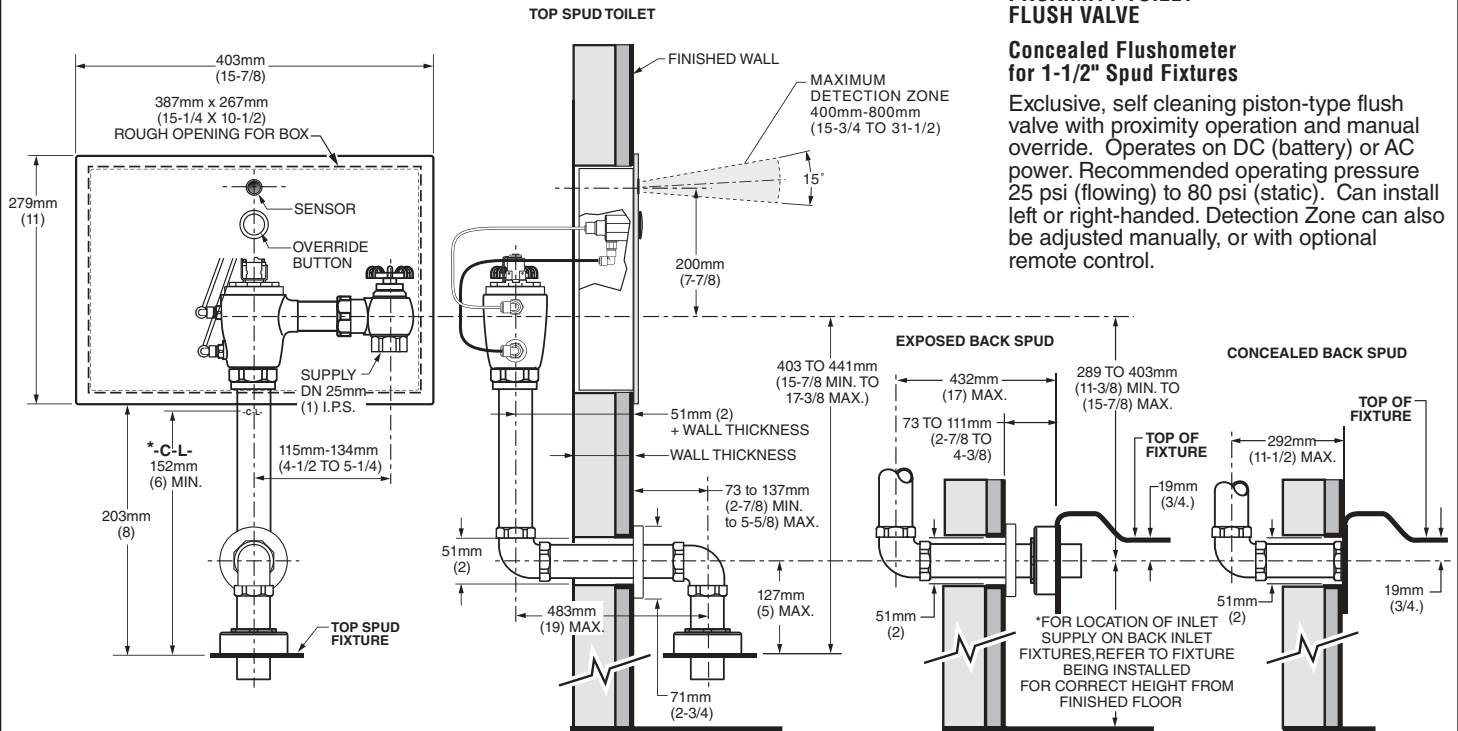

*Note: The Critical Line (-C-L-) on Vacuum Breaker must typically be 6" (152mm) min. above fixture. Consult Codes for details.

RECOMMENDED TOOLS; Fig. 2

1. Teflon Tape
2. Flat Blade Screwdriver
3. Adjustable Wrench
4. Tape Measure
5. Hacksaw
6. Tubing Cutter
7. File
8. For Sweat Connection; Solder and Torch
9. 2.5mm Hex Wrench
10. 1.5mm Hex Wrench

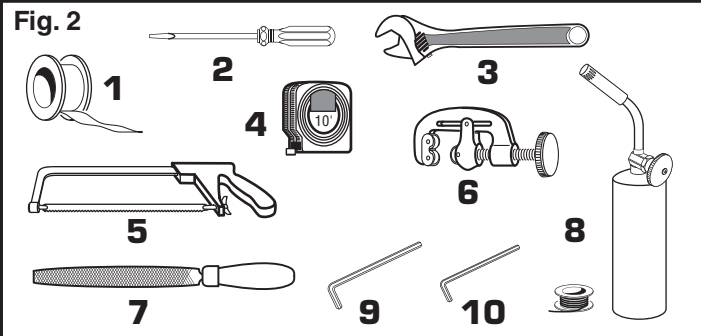

PRIOR TO INSTALLATION

Note: Prior to installing the Selectronic™ Flush Valve the following items must be installed.

1. Water Closet
2. Drain line
3. Water supply line

IMPORTANT:

- All plumbing must be installed in accordance with applicable codes and regulations.
- Water supply lines must be sized to provide an adequate volume of water for each fixture.

- Flush all water lines prior to operation (**See Step 4**). Dirt and debris can cause flush valve to run continuously.
- With the exception of Supply Stop Inlet, **DO NOT** use pipe sealant or plumbing grease on any valve component or coupling!
- Protect the chrome or special finish on chrome plated items.
DO NOT USE toothed tools on finished surfaces to install or service these valves. Also see "Care and Cleaning" section of this manual.
- This product contains mechanical and/or electrical components that are subject to normal wear. These components should be checked on a regular basis and replaced as needed to maintain the valve's performance.

1 INSTALL ELECTRICAL BOX ASSEMBLY; Fig. 3

1. Frame out a 387mm x 267mm (15-1/4 X 10-1/2) rough opening in wall for the WALL BOX (1) at the deminsion shown in Fig.3. **Note:** It is important to keep the opening level.
2. Fasten one end of the SAFETY CHAIN (2) to the WALL BOX (1) with NUT & SCREW (3) provided.
3. Install the BOX FRAME (1) into rough opening in the wall. Level and secure the WALL BOX (1) to the wall opening with screws. **Important: Front face of WALL BOX (1) should be flush with finished wall.**
4. *Cut a 2" hole for supply to fixture at deminsion shown.

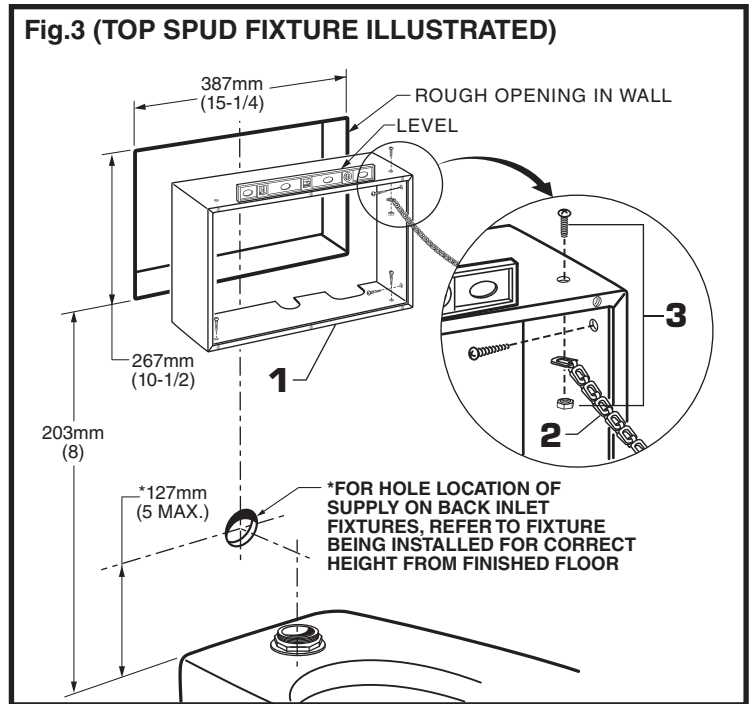

2 INSTALL SWEAT SOLDER ADAPTER; Fig. 4

CAUTION Turn water supplies off before beginning

Note: Control stop inlet is 1" IPS. For optional sweat connection, *install Sweat Solder Adapter (1) (Supplied) for 1" copper pipe supply line.* Fig. 4.

1. Clean the end of the supply pipe. Push the threaded ADAPTER (1) on until it is seated against the internal stop. Sweat the ADAPTER (1) to the pipe.
2. Install the CONTROL STOP (2) to the water supply line with the outlet positioned as required.
3. Support piping as required.

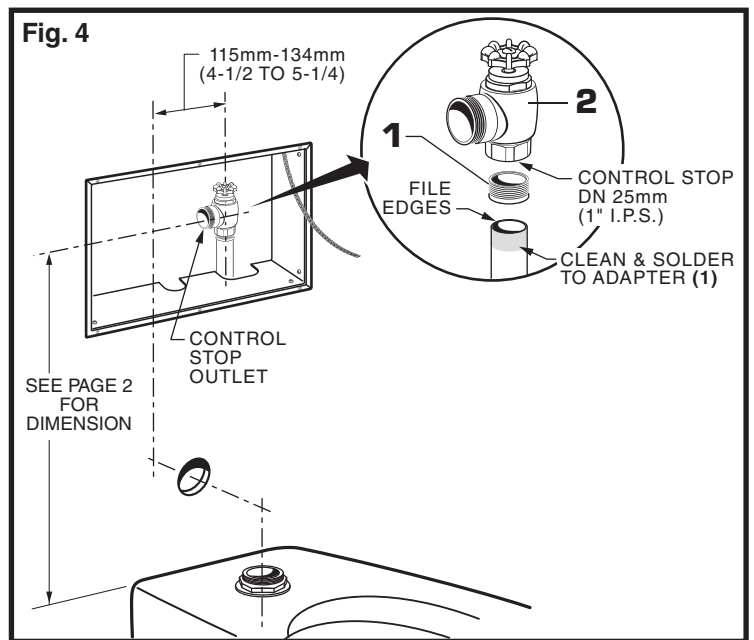

3 FLUSH OUT SUPPLY LINES; Fig. 5

1. Open SUPPLY STOP (1).
2. Turn on water supply to flush line of any debris or sediment.
3. Close SUPPLY STOP (1) and turn off water supply line.

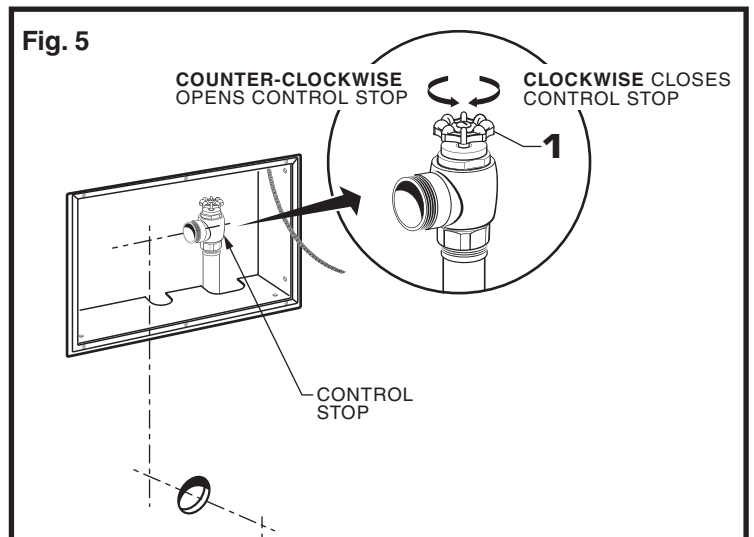

4 INSTALL VACUUM BREAKER AND FLUSH CONNECTIONS; Fig. 6

1. Place the SPUD FLANGE (1) over the spud on the Fixture. Fig. 6.

2. Thread SPUD COUPLING NUT (2) onto Spud. Make sure SEAL WASHER (4) and FRICTION WASHER (3) are installed. Do not tighten fully. Fig. 6.

3. Remove the COUPLING NUTS (6, 6a) from the CHROME ELBOW (5). Make sure you have a TAPERED RUBBER WASHER (7), PLASTIC SUPPORT (8) and SQUARE SEAL WASHER (9). Fig. 6a.

4. Install the SQUARE SEAL WASHER (9) onto the PLASTIC SUPPORT (8) if not already installed. Insert the PLASTIC SUPPORT (8) into the DOWN TUBE (10). Slide the COUPLING NUT (6) onto the DOWN TUBE (10). Connect the COUPLING NUT (6) to the CHROME ELBOW (5) and tighten fully. Insert the DOWN TUBE (10) with CHROME ELBOW (5) into the SPUD COUPLING NUT (2) and push it down. Do not tighten fully. Fig. 6a. **Note: If center line of ELBOW (5) cannot be adjusted to line up with hole in wall, then cut the DOWN TUBE (10) as required.**

5. Measure and cut the HORIZONTAL TUBE (11) to length required. **Important: Make sure that there is a minimum of 1-1/4" for engagement with elbow when making your measurement.** Fig. 6b.

6. Remove the COUPLING NUT (14) from BRASS ELBOW (12) and slide it onto the HORIZONTAL TUBE (11). Install the SQUARE SEAL WASHER (13) onto the PLASTIC SUPPORT (15) if not already installed. Insert the PLASTIC SUPPORT (15) into the HORIZONTAL TUBE (11). Connect the COUPLING NUT (14) to the BRASS ELBOW (12) and tighten fully. Fig. 6b.

7. From behind the wall install the ELBOW AND TUBE ASSEMBLY (12, 11) through the hole in the wall. Install WALL ESCUTCHEON (16) onto HORIZONTAL TUBE (11). Assemble the COUPLING NUT (6a) and TAPERED RUBBER WASHER (7) in the CHROME ELBOW (5) onto the HORIZONTAL TUBE (11). Push the HORIZONTAL TUBE (11) into the CHROME ELBOW (5). Tighten COUPLING NUT (6a) but not fully. Fig. 6b.

8. **For back spud installations:** Follow steps #1 and #2 to install the spud coupling kit. Push the HORIZONTAL TUBE (11) into the spud connection on the back of the fixture. Do not tighten fully. If spud coupling kit is not required install HORIZONTAL TUBE (11) into back spud on fixture and hand tighten. Fig. 6b.

9. **All installations:** If required cut scored VACUUM BREAKER PIPE (17) to fit, leave a minimum of 1-1/4" (32mm) of pipe to ensure engagement with compression coupling. Assemble the COUPLING NUT (18) and TAPERED RUBBER WASHER (19) in the BRASS ELBOW (12) onto the VACUUM BREAKER PIPE (17). Install VACUUM BREAKER PIPE (17) into BRASS ELBOW (12) and hand tighten COUPLING NUT (18). Fig. 6c.

Note: If cutting VACUUM BREAKER PIPE (16) to size, note that Critical Line (C/L) on Vacuum Breaker must typically be 6" (152mm) above fixture. Consult Code for details.

Fig. 6

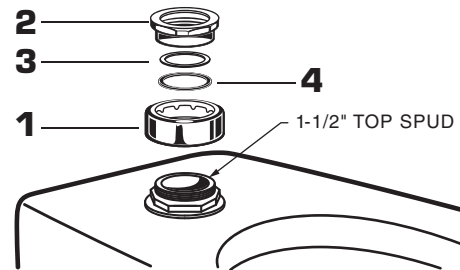

Fig. 6a

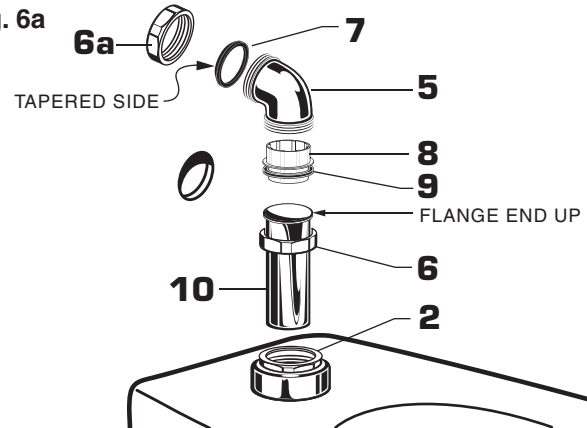

Fig. 6b

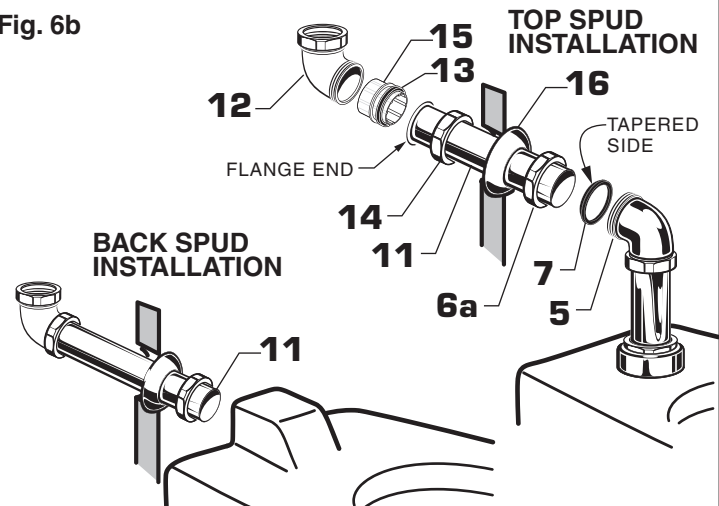
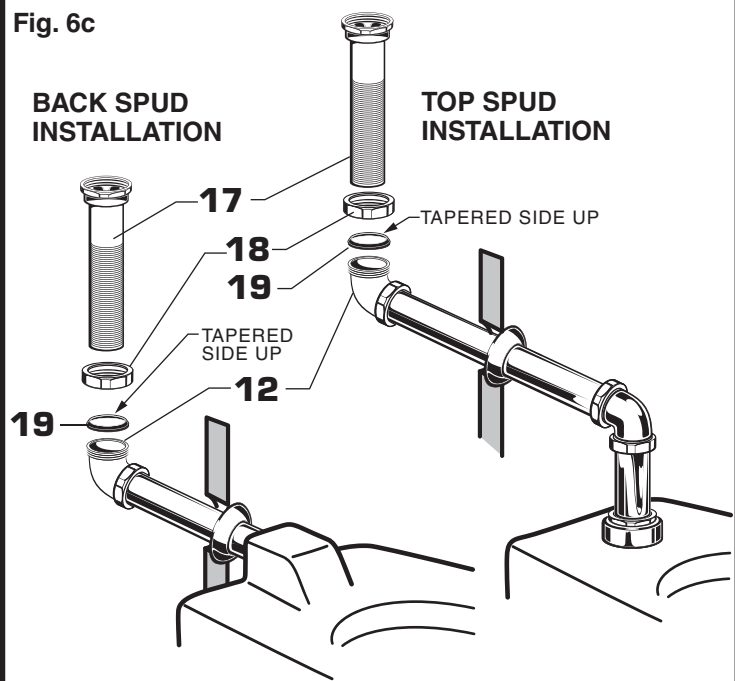
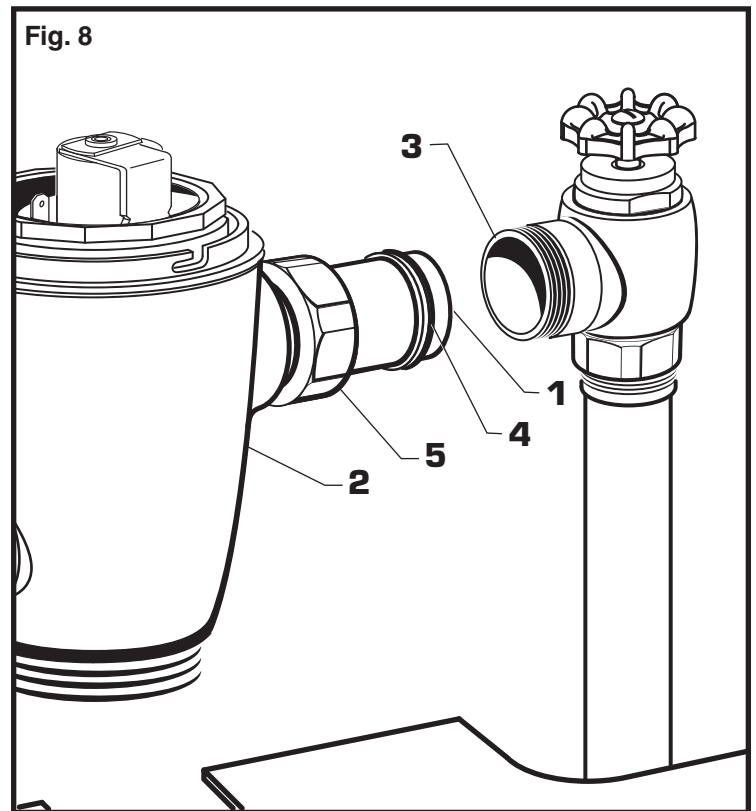

Fig. 6c



5 INSTALL FLUSH VALVE; Fig. 8

1. Insert the side ADJUSTABLE TAILPIECE (1) on the FLUSH VALVE (2) into the SUPPLY STOP (3). Lubricate the TAILPIECE O-RING (4) with water if necessary. Lightly tighten COUPLING NUT (5). **Fig. 8.**
Important: Do not use lubricants (other than water) or any type of thread sealing paste or tape.



6 CONNECT FLUSH VALVE TO PIPING; Fig. 9

1. Align the FLUSH VALVE (2) (Fig. 9) directly above the VACUUM BREAKER TUBE (7) and VACUUM COUPLING NUT (6). Make sure that GASKET (10) is installed.

Note: There is a +13mm, -6mm (+1/2, -1/4) tolerance for the 121mm (4-3/4) dimension. Fig. 9.

2. Pull the VACUUM BREAKER TUBE (7) up to meet the threaded FLUSH VALVE CONNECTION (8) and hand tighten the COUPLING NUT (6). Align all components of the flush valve assembly. **Fig. 9.**

3. Lightly tighten the TAILPIECE COUPLING NUT (5) connection first, then the VACUUM BREAKER COUPLING NUT (6) and finally the SPUD COUPLING NUT (9). Once aligned correctly, use a wrench to tighten all couplings to make water tight connections. **Fig. 9.**

4. Secure piping with in wall as required.

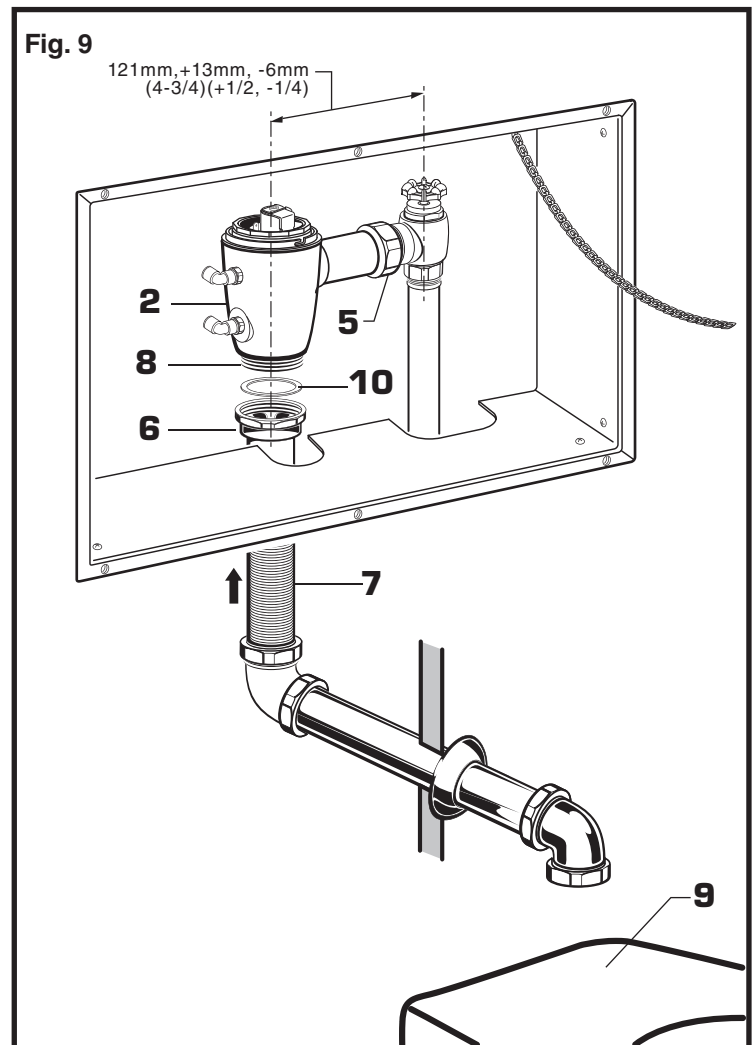

7 CONNECT ELECTRICAL BOX, FRONT PANEL AND (AC POWER);

Fig. 10

1. Peel off the protective film from the side of the ELECTRICAL BOX (1). Press the adhesive side of the ELECTRICAL BOX (1) against the left wall of the WALL BOX (2). The ELECTRICAL BOX (1) can now be removed and installed as needed. Fig. 10.

2. Remove the ELECTRICAL BOX (1) from the WALL BOX (2). Remove the four COVER SCREWS (3) and COVER (4). Pull out the CIRCUIT BOARD (5) Fig. 10a.

3. From back of ELECTRICAL BOX (1) (View "A") remove SPLIT PLUG (6a) from POWER SUPPLY GROMMET (6). Insert POWER CORD CONNECTOR (8) through POWER SUPPLY GROMMET (6). Insert POWER CORD (7) into SPLIT PLUG (6a). Push SPLIT PLUG (6a) into POWER SUPPLY GROMMET (6) to seal. Fig. 10a .

4. Insert POWER CORD CONNECTOR (8) into RECEPTOR (9) on CIRCUIT BOARD (5). Install CIRCUIT BOARD (5) back into ELECTRICAL BOX (1). Fig. 10a.

5. Attach the SAFETY CHAIN (10) from the BOX FRAME (2) to the FRONT PANEL (11). Unthread the left MOUNTING SCREW (12) for the sensor as shown. Install the MOUNTING SCREW (12) through the SAFETY CHAIN (10) and back into the mounting post. Tighten securely. Fig. 10b, View "B".

7. Remove the SPLIT PLUG (13a) from SENSOR WIRE GROMMET (13). Insert SENSOR WIRE CONNECTOR (14) through SENSOR WIRE GROMMET (13). Insert SENSOR WIRE (15) into SPLIT PLUG (13a). Push SPLIT PLUG (13a) into SENSOR WIRE GROMMET (13) to seal. Fig. 10c.

8. Insert SENSOR WIRE CONNECTOR (14) into CIRCUIT BOARD RECEPTOR (16) slot. Fig. 10c.

9. Replace COVER (4). Tighten COVER SCREWS (3) firmly.

Fig. 10

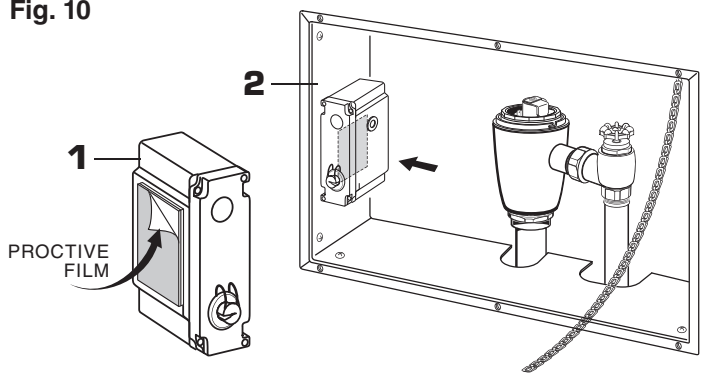

Fig. 10a

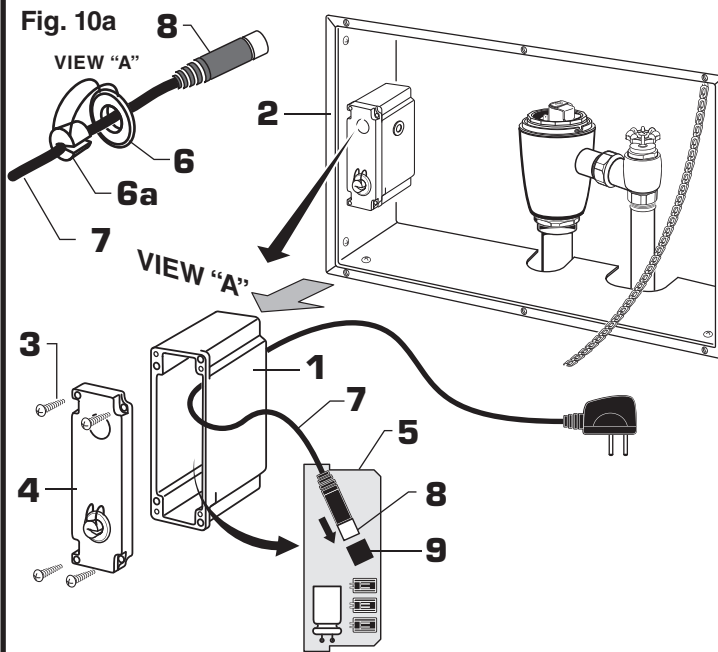

Fig. 10b

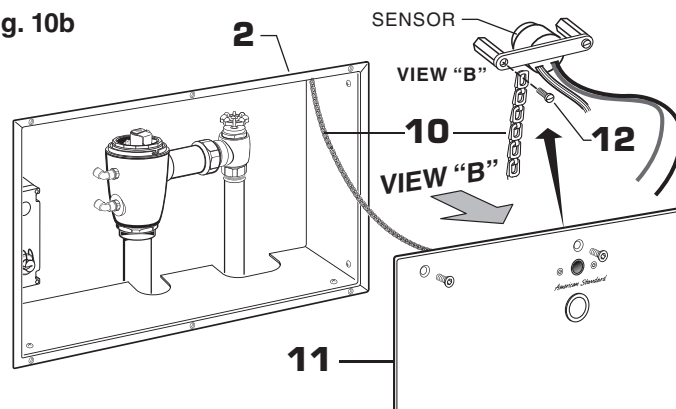
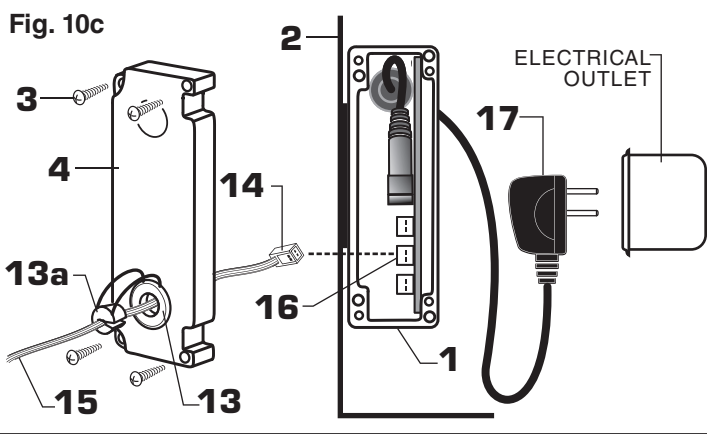

Fig. 10c



8 CONNECT ELECTRICAL BOX, FRONT PANEL AND (DC POWER);

Fig. 11

1. Peel off the protective film from the side of the ELECTRICAL BOX (1). Press the adhesive side of the ELECTRICAL BOX (1) against the left wall of the WALL BOX (2). The ELECTRICAL BOX (1) can now be removed and installed as needed. **Fig. 11.**

2. Remove the four COVER SCREWS (3) and COVER (4) from ELECTRICAL BOX (1). **Fig. 11a.**

3. Install BATTERY (5) into HOLDER (6) on DC circuit board. Press BATTERY (5) down (contacts facing downward) into position until tabs lock BATTERY (5) into place. **Fig. 11a.**

5. Attach the SAFETY CHAIN (7) from the BOX FRAME (2) to the FRONT PANEL (8). Unthread the left MOUNTING SCREW (9) for the sensor as shown. Install the MOUNTING SCREW (9) through the SAFETY CHAIN (7) and back into the mounting post. Tighten securely. **Fig. 11b, View "B".**

7. Remove the SPLIT PLUG (10a) from SENSOR WIRE GROMMET (10). Insert SENSOR WIRE CONNECTOR (11) through SENSOR WIRE GROMMET (10). Insert SENSOR WIRE (12) into SPLIT PLUG (10a). Push SPLIT PLUG (10a) into SENSOR WIRE GROMMET (10) to seal. **Fig. 11c.**

8. Insert SENSOR WIRE CONNECTOR (11) into CIRCUIT BOARD RECEPTOR (13) slot. **Fig. 11c.**

9. Replace COVER (4). Tighten COVER SCREWS (3) firmly.

Fig. 11

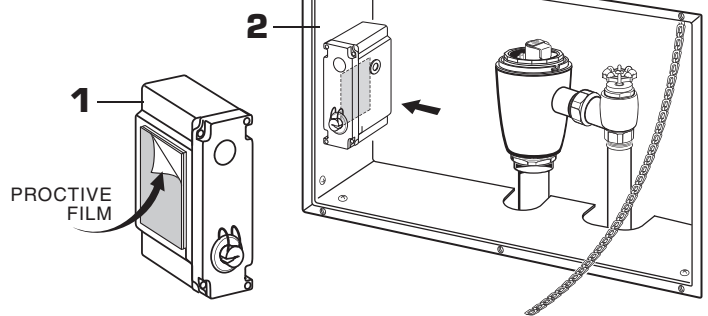

Fig. 11a

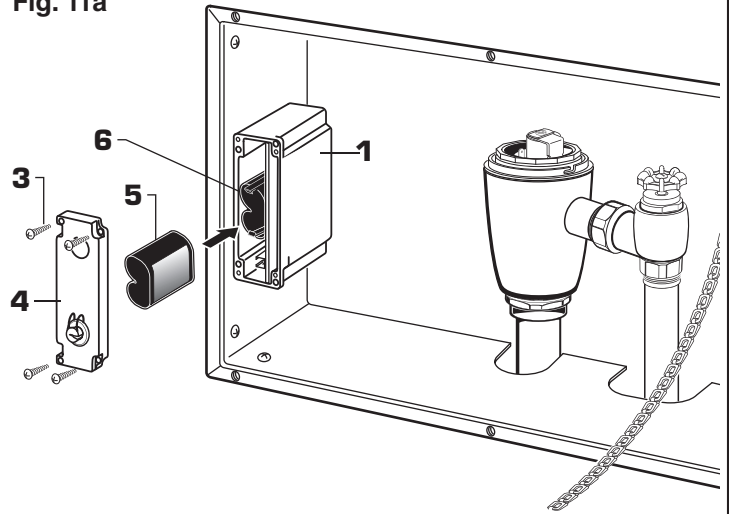

Fig. 11b

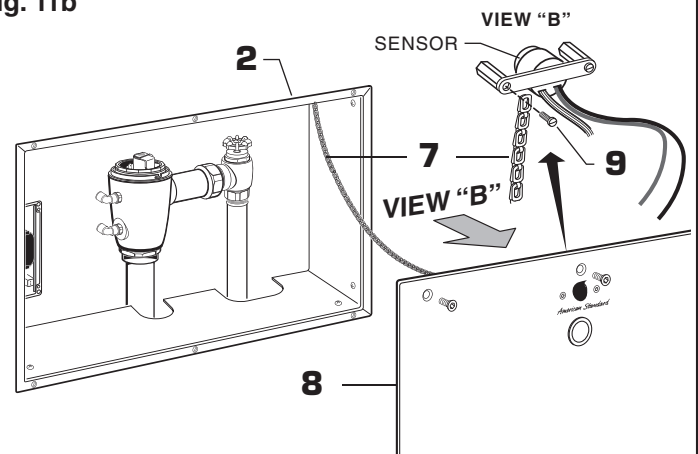
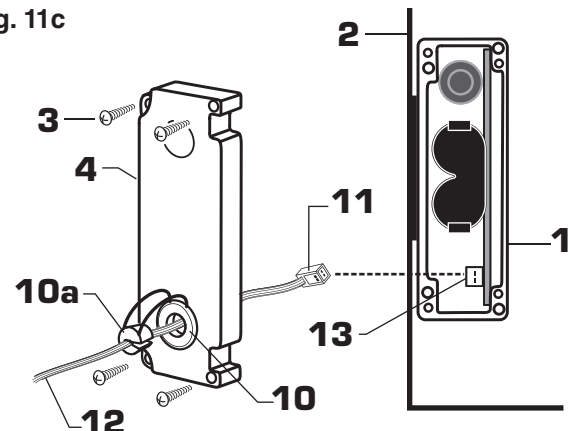
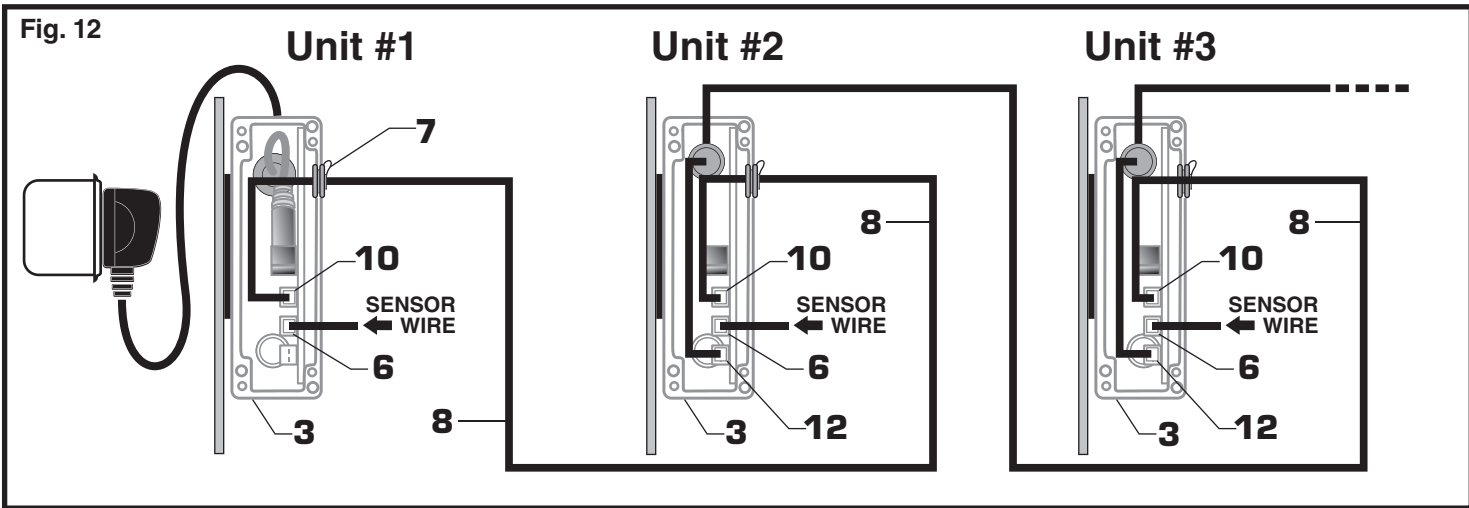

Fig. 11c





9 FOR AC-VERSION (MULTI HOOK-UP); Fig. 12, 12 a

1. Remove the COVER SCREWS (1) and COVER (2) from each ELECTRICAL BOX (3).

2. See AC Version Electrical Hook-up for Unit #1 of the Multi hook-up.

3. Install SENSOR WIRE GROMMET (4) and FLUSH VALVE SENSOR WIRE (5) into the COVER (2) of each unit. Insert the flush valve sensor wire connector into the CENTER CIRCUIT BOARD RECEPTOR (6) on each unit. **Fig. 12a.**

4. Remove the SPLIT PLUG (7a) from the SENSOR WIRE GROMMET (7) on the right side of each ELECTRICAL BOX (3).

5. Take the 10 ft. EXTENSION WIRE (8) from Unit #2 and insert one end of the EXTENSION WIRE CONNECTOR (9) through the SENSOR WIRE GROMMET (7) on right side of Unit #1. Insert EXTENSION WIRE (8) into SPLIT PLUG (7a). Push SPLIT PLUG (7a) into SENSOR WIRE GROMMET (7) to seal. Insert EXTENSION WIRE CONNECTOR (9) into UPPER CIRCUIT BOARD RECEPTOR (10). **Fig. 12a.**

6. Insert other end of EXTENSION WIRE (8) into SENSOR WIRE GROMMET (7) on right side of Unit #2. Insert that EXTENSION WIRE CONNECTOR (9) into the UPPER CIRCUIT BOARD RECEPTOR (10) of Unit #2. **Fig. 12b.**

7. Insert additional SENSOR WIRE GROMMET (11) included with Unit #2 into the knock-out opening in the top of the ELECTRICAL BOX (3). Take the 10 FT. EXTENSION WIRE (8) from Unit #3 and insert one end into the SENSOR WIRE GROMMET (11) in the top of the ELECTRICAL BOX (3) of Unit #2. Insert EXTENSION WIRE CONNECTOR (9a) into BOTTOM CIRCUIT BOARD RECEPTOR (12) on Unit #2. **Fig. 12b.**

9. Insert the other end of the EXTENSION WIRE (8) from Unit #3 into the SENSOR WIRE GROMMET (7) on the right side of Unit #3. Insert EXTENSION WIRE CONNECTOR (9) into UPPER CIRCUIT BOARD RECEPTOR (10) on Unit #3.

10. Repeat Steps 7 to 9 as necessary for additional Multi-AC Units.

11. Once all wire connections are made. Install the COVER (2) and COVER SCREWS (1) onto each ELECTRICAL BOX (3).

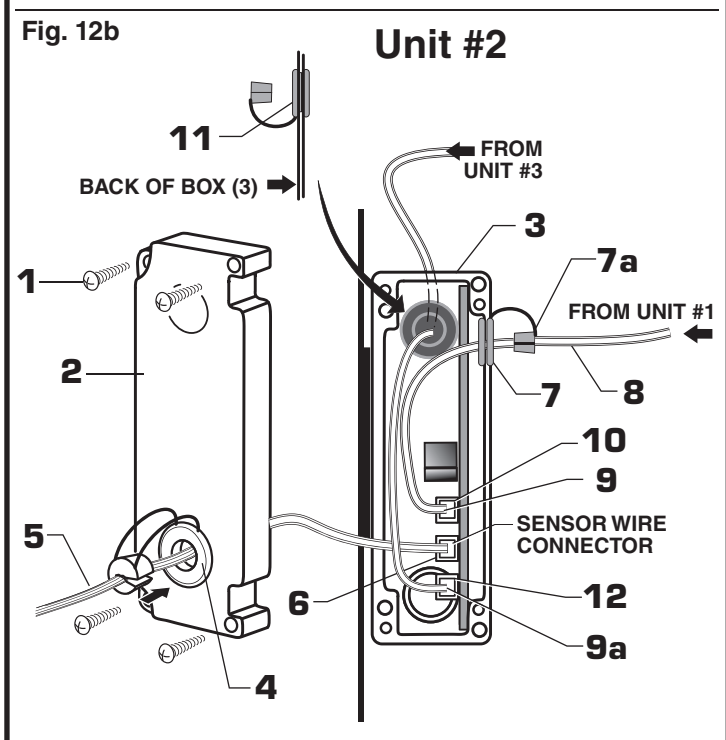
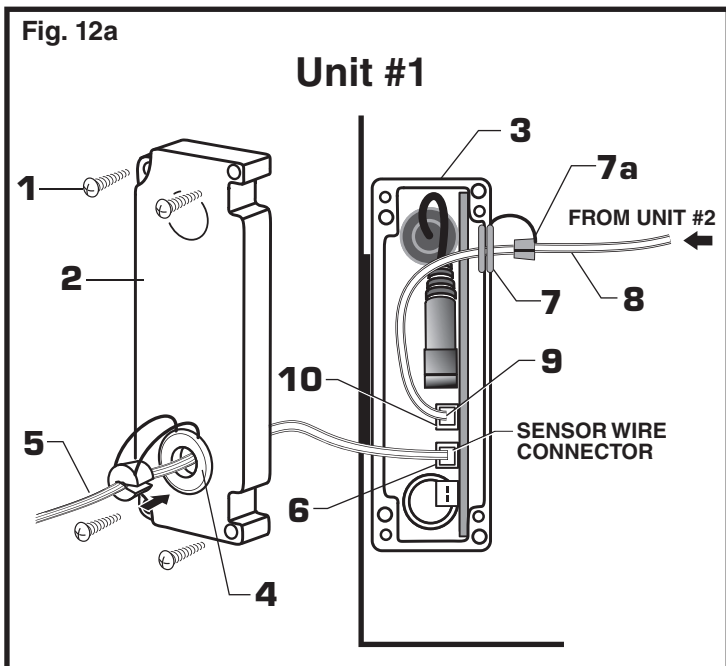

10 CONNECT OVERRIDE HOSES, Fig. 13

1. Push the BLACK HOSE (1) into the BOTTOM HOSE CONNECTOR (2) and the other end into the back of the OVERRIDE SWITCH (3).

2. Push the BLUE HOSE (4) into the TOP HOSE CONNECTOR (5) on the valve and the other end into the BOTTOM CONNECTOR (6) on the OVERRIDE SWITCH (3).

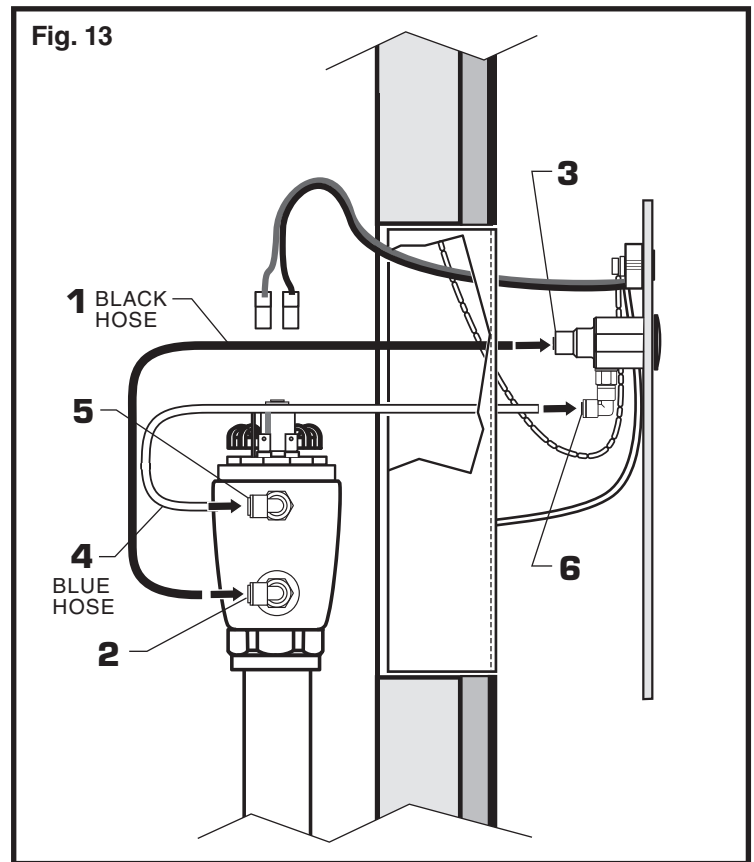

11 CONNECT SOLENOID WIRING AND POWER SUPPLY; Fig. 14

1. Push the RED WIRE CONNECTOR (1) onto the SOLENOID PIN (2) with Red Stripe. Push the BLACK WIRE CONNECTOR (3) onto the other SOLENOID PIN (4). Push the wire connectors all the way down.

2. Code approved Electrical Outlet provided by others. (120V 50/60 Hz)

3. Plug AC POWER SUPPLY (5) into Outlet.

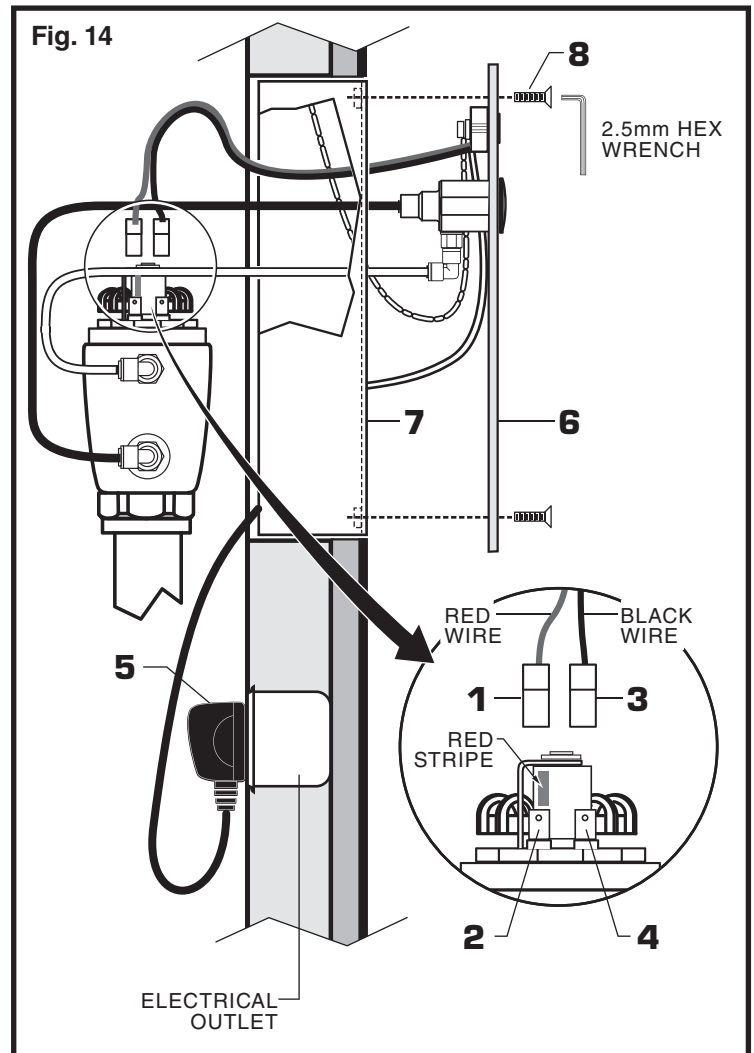

12 ADJUST SUPPLY STOP; Fig. 15

IMPORTANT: To avoid overflowing, the SUPPLY STOP (2) must never be opened to the point where the flow from the valve exceeds the flow capacity of the fixture. The fixture must be able to handle a continuous flow in case of a flush valve failure. Valve is designed to provide stated flush volume with a 25 GPM flow rate.

1. After installation is complete, remove FRONT PANEL (1). Peel off the PROTECTIVE FILM (2) from the sensor. Standing to one side, block the sensor with your hand for 10 seconds. **Remove your hand and listen for audible “click” from within the valve.**
2. Turn on SUPPLY STOP (3) 1/4 turn to 1/2 turn (CCW) and test for leaks. **Note: Unit may flush for approximately 5 to 10 sec. when water is first turned on. If flow persists, turn water off and repeat step #1 above.**
3. Actuate the FLUSH VALVE:
 - A) Cover sensor with hand for 10 seconds.
NOTE: Stand outside of sensor detection area.
 - B) Remove hand from in front of the sensor; unit will flush in approximately 3 seconds.
4. Adjust SUPPLY STOP (3) after each flush until the stated flush volume is achieved, no splashing occurs and the fixture is properly cleansed. Replace FRONT PANEL (1).
5. Attach the FRONT PANEL (1) to the WALL BOX (4) with the six MOUNTING SCREWS (5). Use a 2.5mm Hex Wrench supplied to secure FRONT PANEL (1).

13 INSTALL NEW BATTERY; Fig. 16

1. Remove the six SCREWS (1) that attach the FRONT PANEL (2) to the BOX FRAME (3). **Fig. 16.**
2. Remove the four COVER SCREWS (4) and COVER (5) from ELECTRICAL BOX (6). **Fig. 16a.**
3. Disconnect GREY SENSOR WIRE (7) from CIRCUIT BOARD (8).
4. Remove CIRCUIT BOARD (8) from ELECTRICAL BOX (6). **Fig. 16a.**
5. With your thumbs, spread the two TABS (9) on battery holder apart and remove the old BATTERY (10).
6. Replace CIRCUIT BOARD (8) into ELECTRICAL BOX (6).
7. Install NEW BATTERY (10a) into holder on DC circuit board. Press BATTERY (10a) down (contacts facing downward) into position until TABS (9) lock BATTERY (10a) into place.
8. Connect GREY SENSOR WIRE (7) to CIRCUIT BOARD (8).
9. Install COVER (5) and SCREWS (4).
10. Attach FRONT PANEL (2) to WALL BOX (3).

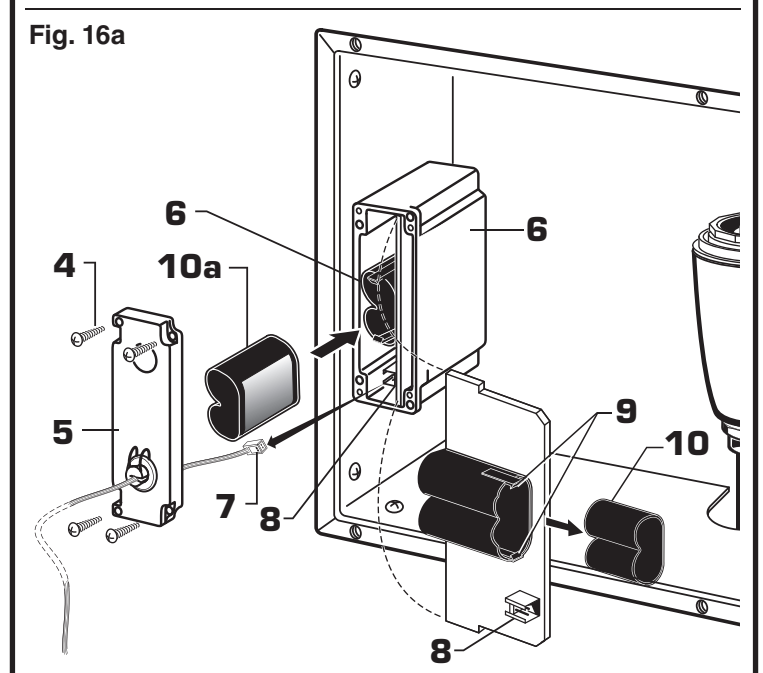
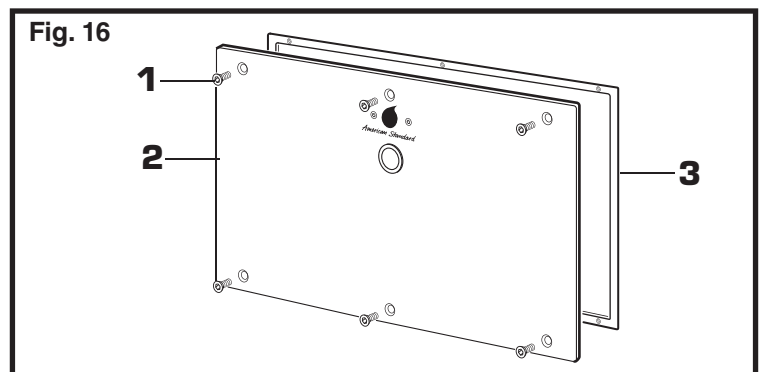
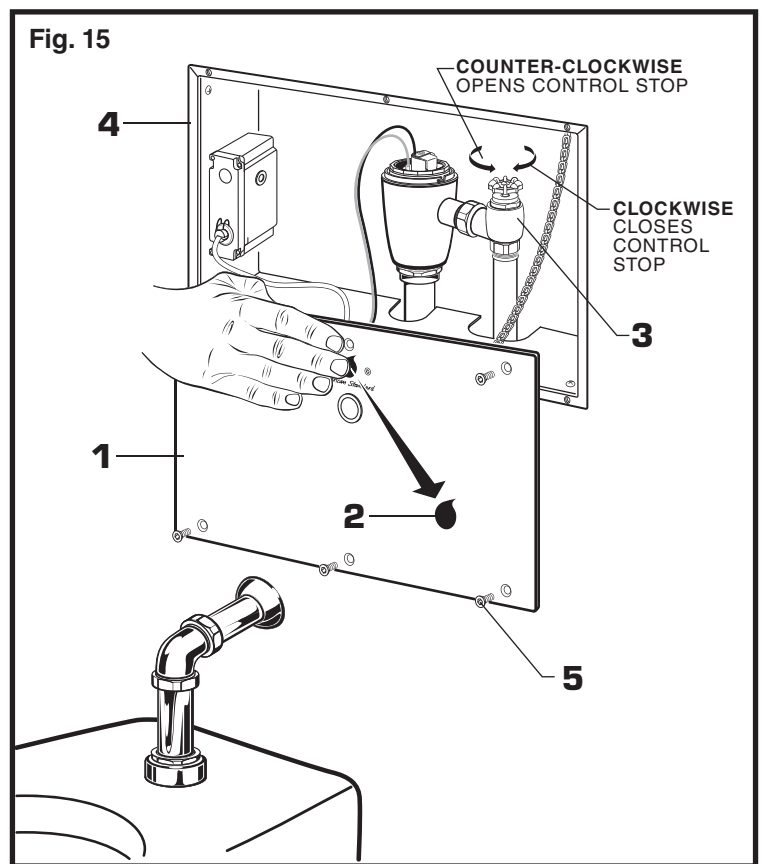

14 HOW TO SET DETECTION RANGE (If Required) ; Fig. 18 & 19

Note: The detection distance is preset and is ideal for most installations. Should an adjustment be required follow the steps below.

1. Remove FRONT PANEL (1).
2. Remove the four COVER SCREWS (2) and COVER (3) from ELECTRICAL BOX (4). Fig. 18.
3. Disconnect GREY SENSOR WIRE (5) from CIRCUIT BOARD (6).
4. Keeping hands away from the front of the sensor, reconnect the GREY SENSOR WIRE (5) and quickly hang the FRONT PANEL (1) onto the WALL BOX (7). Do not secure the FRONT PANEL (1) at this time. **Note: You have 5 seconds after connecting cable to begin program process.**
5. While the SENSOR CONTROL LED (8) is blinking slowly, place your hand 1 to 2 in. (30-50mm.) in front of the sensor. Fig. 19.
6. When the LED (8) stops blinking and stays "ON", move your hand to the desired position from sensor (detection zone, 15-3/4" to 31-1/2", 400 to 800mm) and hold in place until the LED (8) begins to blink again. **Note: Maximum Detection Zone is 15-3/4" to 31-1/2", 400 to 800mm) from sensor. Fig. 19a.**
7. Once the SENSOR CONTROL LED (8) begins to blink again, remove your hand from the detection zone. When the flashing stops, the detection distance is set.
8. Replace COVER (4). Tighten COVER SCREWS (2) firmly. Fig. 18.

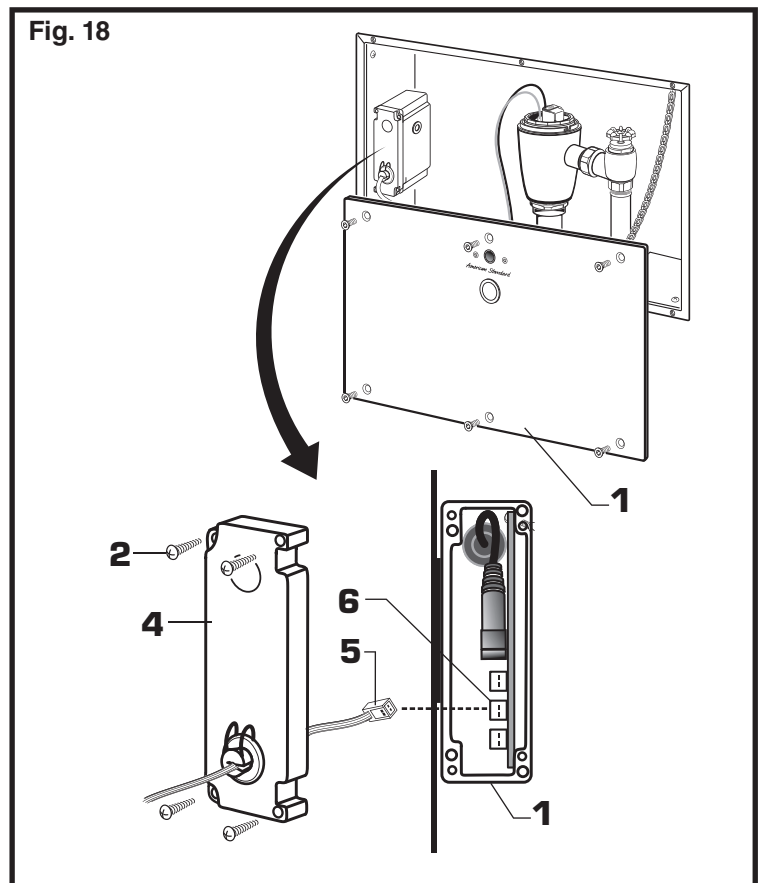

9. Replace the FRONT PANEL (1).
10. Actuate the FLUSH VALVE:
 - A) Cover sensor with hand for 10 seconds. **NOTE: Stand outside of sensor detection area.**
 - B) Remove hand from in front of the sensor, unit will flush in approximately 3 seconds.

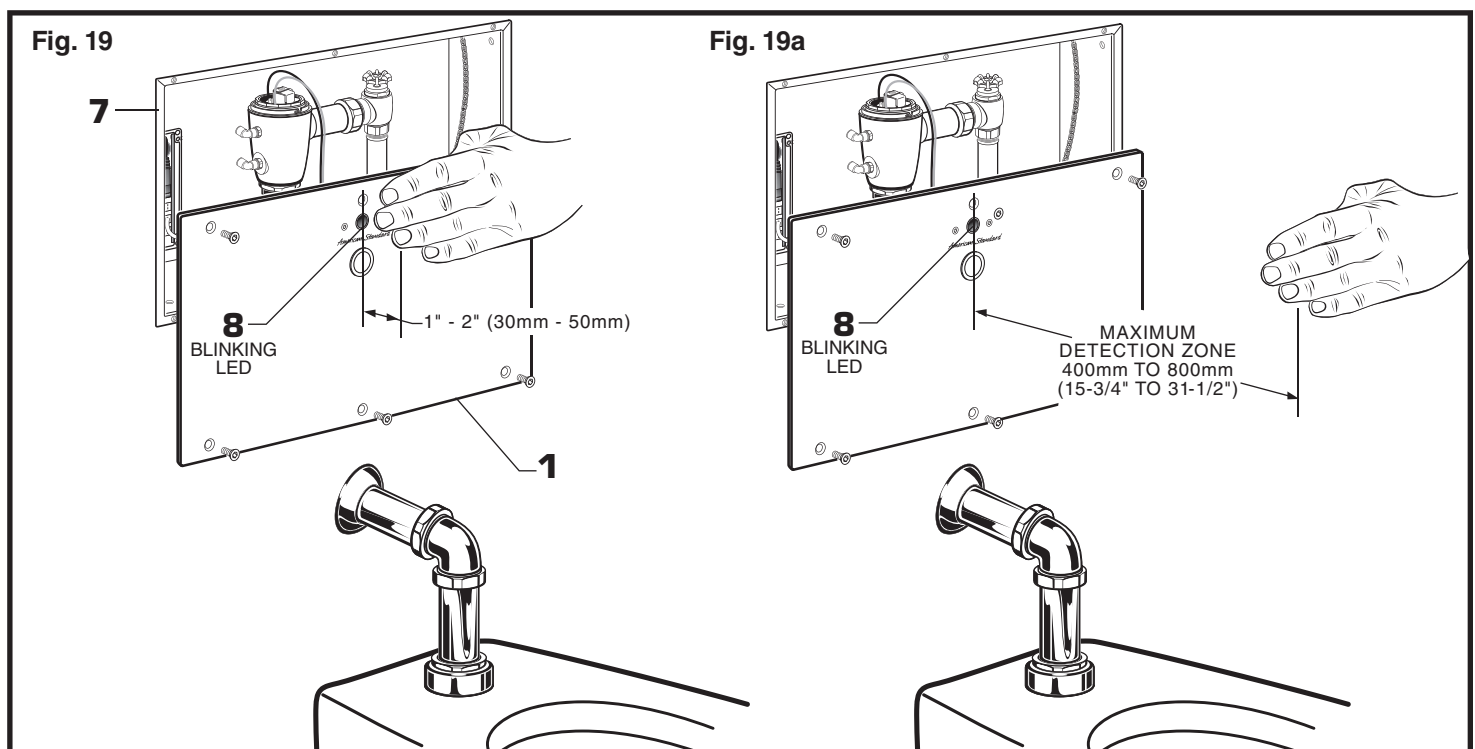

UNIT DOES NOT FLUSH AT ALL

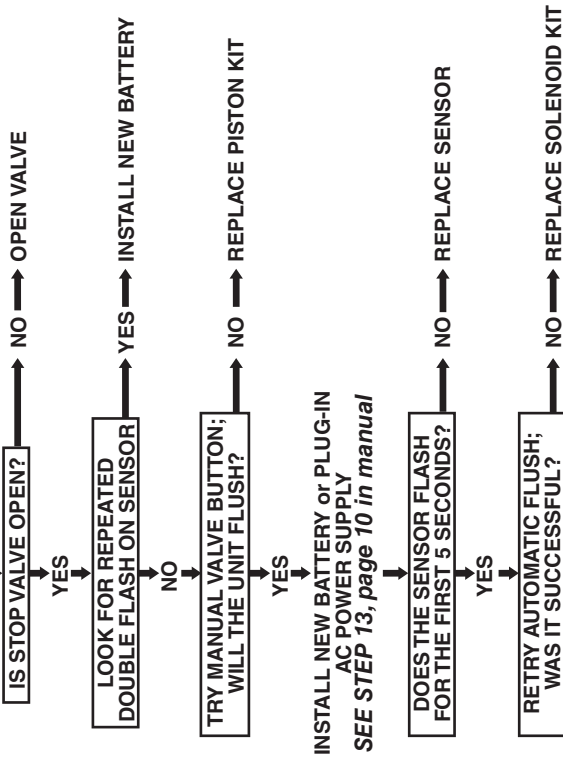

UNIT WILL ONLY FLUSH MANUALLY

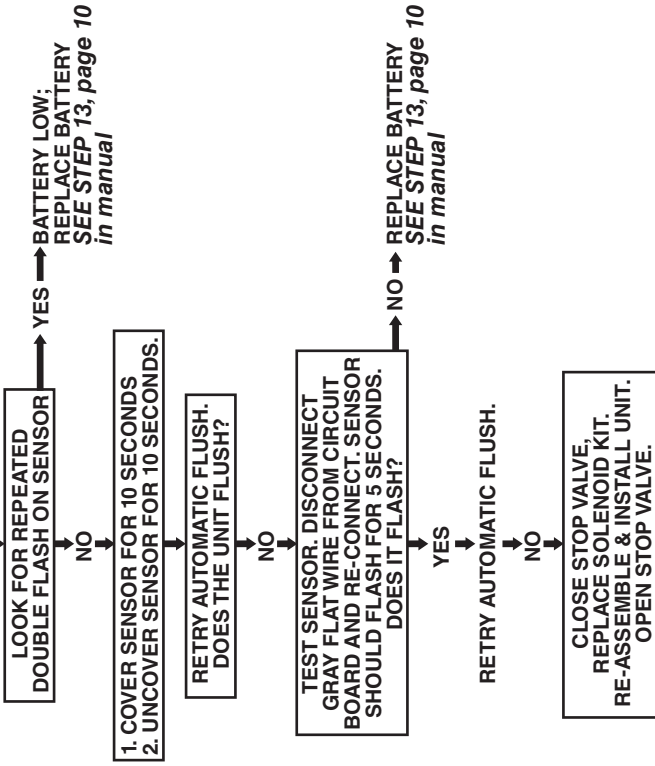

UNIT IS CONTINUOUSLY FLUSHING

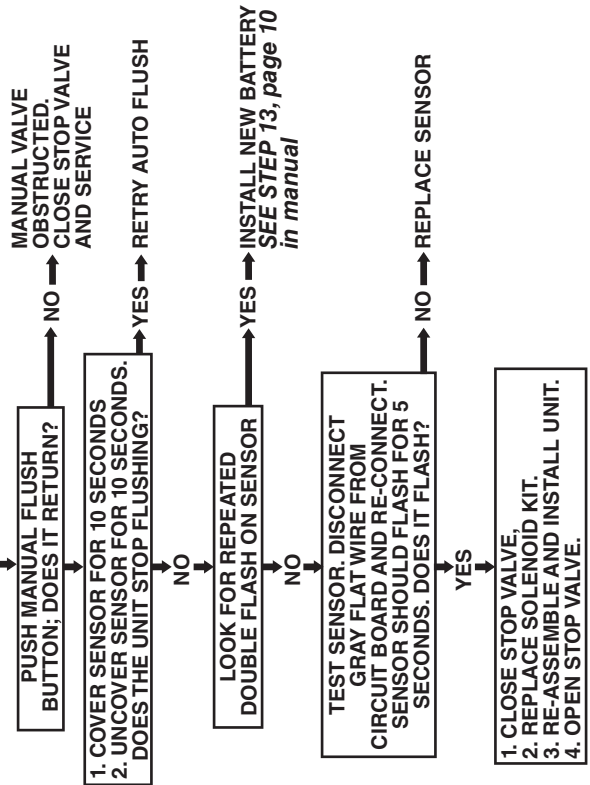

TROUBLESHOOTING FLOW CHARTS



HOT LINE FOR HELP
 1 (800) 442-1902
 Weekdays 8:00 a.m. to 6:00 p.m. EST
 IN MEXICO 01-800-839-1200
 IN CANADA 1-800-387-0369 (TORONTO 1-905-306-1093)
 Weekdays 8:00 a.m. to 7:00 p.m. EST

Product names listed herein are trademarks of AS America, Inc.

American Standard

SELETRONIC™ PROXIMITY TOILET CONCEALED FLUSH VALVE 1.28 & 1.6 GPF

MODEL NUMBERS	
6065.32X	6065.36X
6067.32X	6067.36X
6068.32X	6068.36X

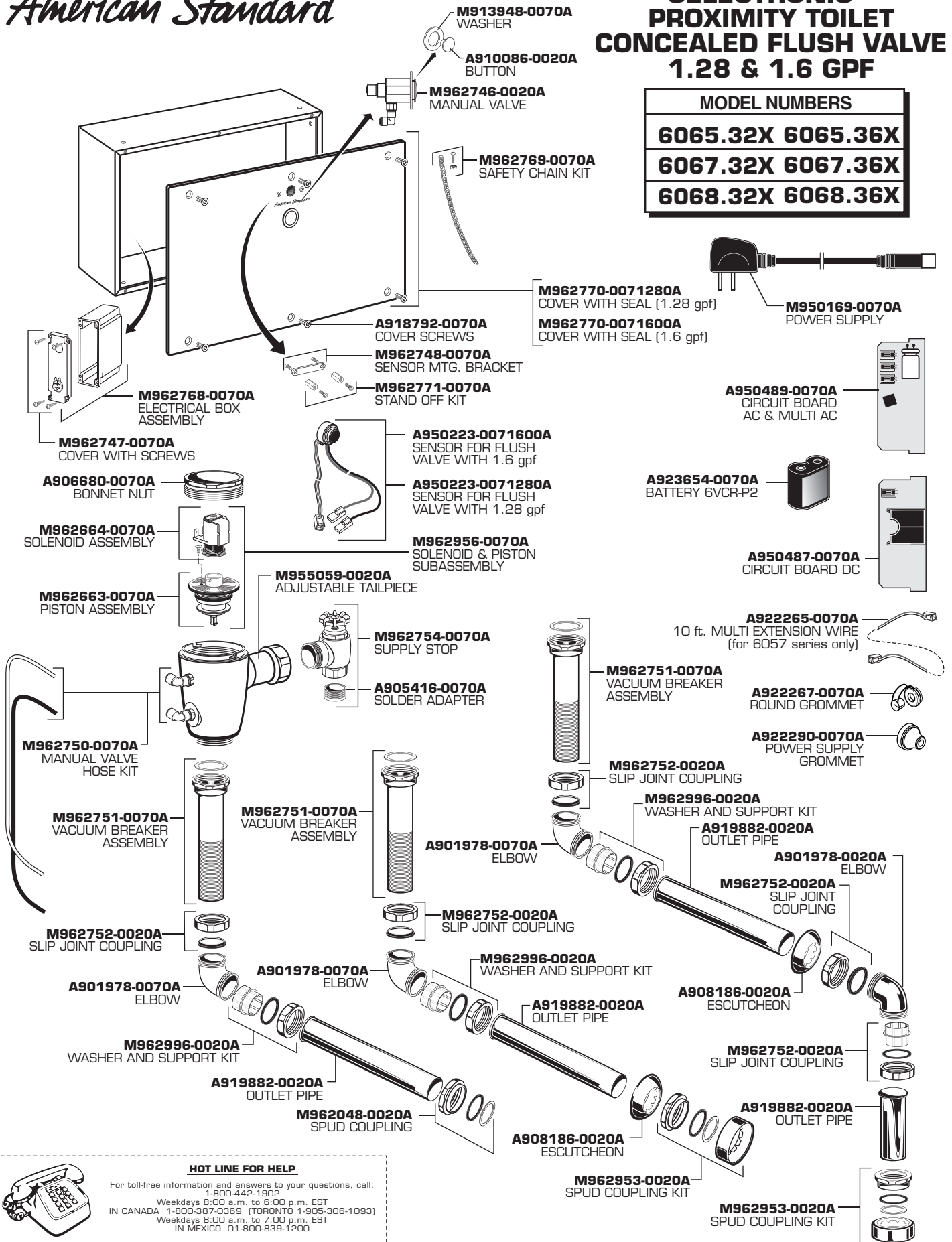

HOT LINE FOR HELP

For toll-free information and answers to your questions, call:
1-800-442-1902
Weekdays 8:00 a.m. to 6:00 p.m. EST
IN CANADA 1-800-387-0369 (TORONTO 1-905-306-1093)
Weekdays 8:00 a.m. to 7:00 p.m. EST
IN MEXICO 01-800-639-1200

Product names listed herein are trademarks of American Standard Inc.
© AS America, Inc. 2009