

SELECTRONIC™ PROXIMITY TOILET CONCEALED FLUSH VALVE 1.28 & 1.6 GPF

MODEL NUMBERS	
6065.22X	6065.26X
6067.22X	6067.26X
6068.22X	6068.26X

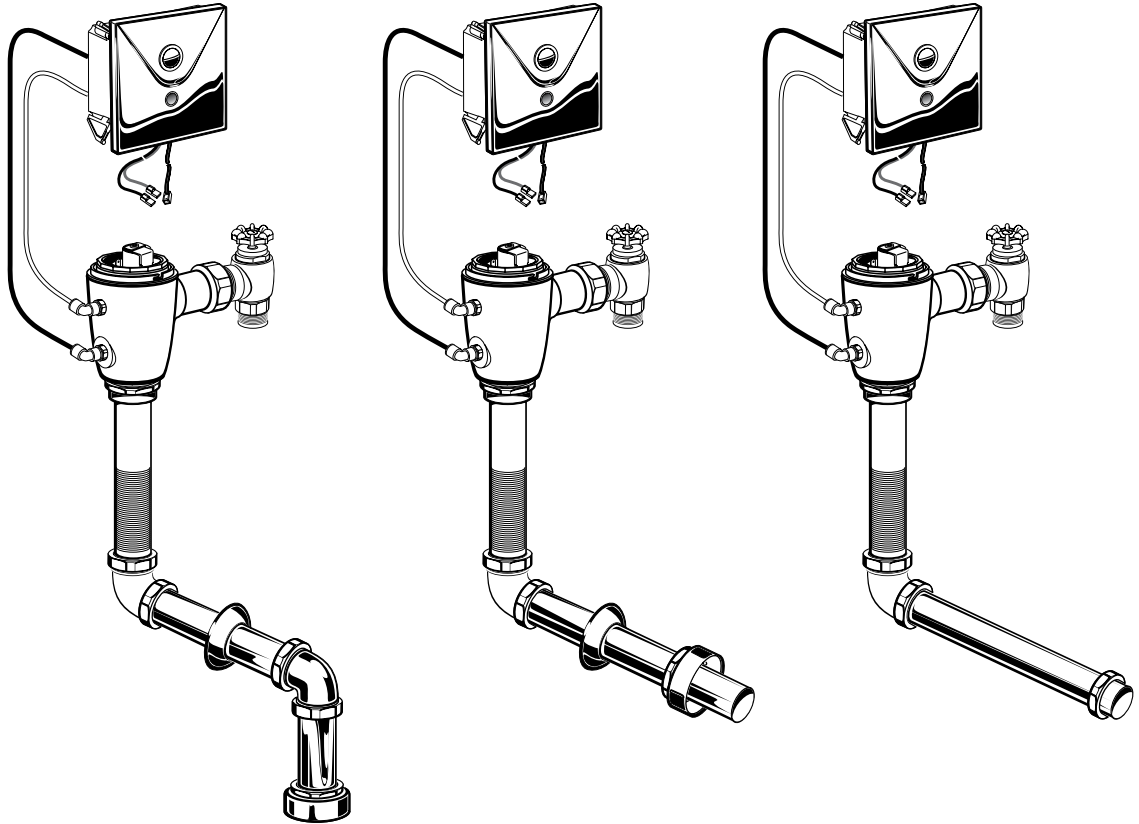

Concealed Flushometer for 1-1/2" Top or Back Spud Bowls

CLOG RESISTANT

- Self-cleaning piston valve prevents clogging and reduces maintenance.

ONE SENSOR FITS ALL

- Only 1 sensor for entire Selectronic™ line of faucets, urinals, and flush valves.
- Range can be adjusted manually or with optional remote control.
- Sensor Features Low Battery Indicator.

Certified to comply with ASME A112.19.2M
© 2010 AS America, Inc.

M968550 REV. 1.6

American Standard

NOTE TO INSTALLER: Please give this manual to the customer after installation.

To learn more about American Standard Faucets visit our website at: www.americanstandard-us.com
or U.S. customer's e-mail us at: faucetsupport@americanstandard.com

For Parts, Service, Warranty or other Assistance,
please call **1-800-442-1902 (In Canada: 1-800-387-0369)**
(In Toronto Area only: 1-905-3061093)

Thank you for selecting American-Standard...the benchmark of fine quality for over 100 years. To ensure that your installation proceeds smoothly--please read these instructions carefully before you begin.

UNPACKING

All American Standard Products Are Water Tested At Our Factory. Some Residual Water May Remain In The Valve During Shipping.

1. Remove the Flush Valve items from the carton. The illustration below shows all items after they have been removed from the carton. Some items may be packaged partially assembled to other items.

- | | | |
|----------------------------|-------------------------------------------------------------|------------------------------------------------|
| 1. Flush Valve Assembly | 5. Sweat Solder Adapter | 7c. Vacuum Breaker Flush Connection (Top Spud) |
| 2. Electrical Box | 6. Manual Override Hoses | 8a. AC Power Supply [Model# 6067] |
| 3. Cover Plate with Sensor | 7a. Vacuum Breaker Flush Connection (Wall-Mount Back Spud) | 8b. DC Power Supply |
| 4. Supply Stop | 7b. Vacuum Breaker Flush Connection (Floor-Mount Back Spud) | 8c. 10' Extension Wire for Multi-AC |
| | | 9. Installation Instructions |

CARE INSTRUCTIONS FOR CHROME PLATED ITEMS:

DO: SIMPLY RINSE THE PRODUCT CLEAN WITH CLEAR WATER. DRY WITH A SOFT COTTON FLANNEL CLOTH.

DO NOT: DO NOT CLEAN THE PRODUCT WITH SOAPS, ACID, POLISH, ABRASIVES, HARSH CLEANERS, OR A CLOTH WITH A COARSE SURFACE.

DO NOT REMOVE PROTECTIVE FILM FROM SENSOR EYE UNTIL INSTALLATION IS COMPLETE.

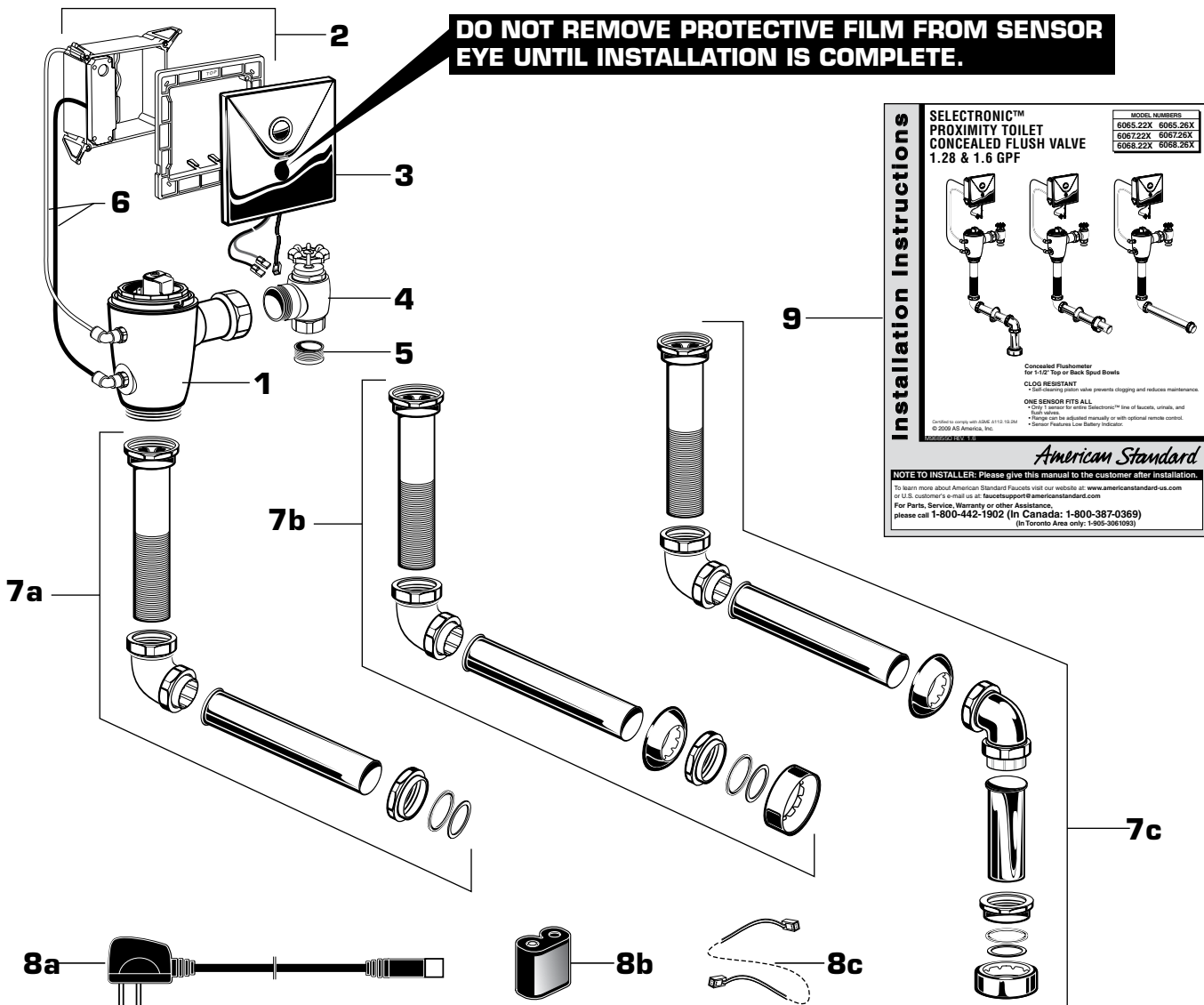
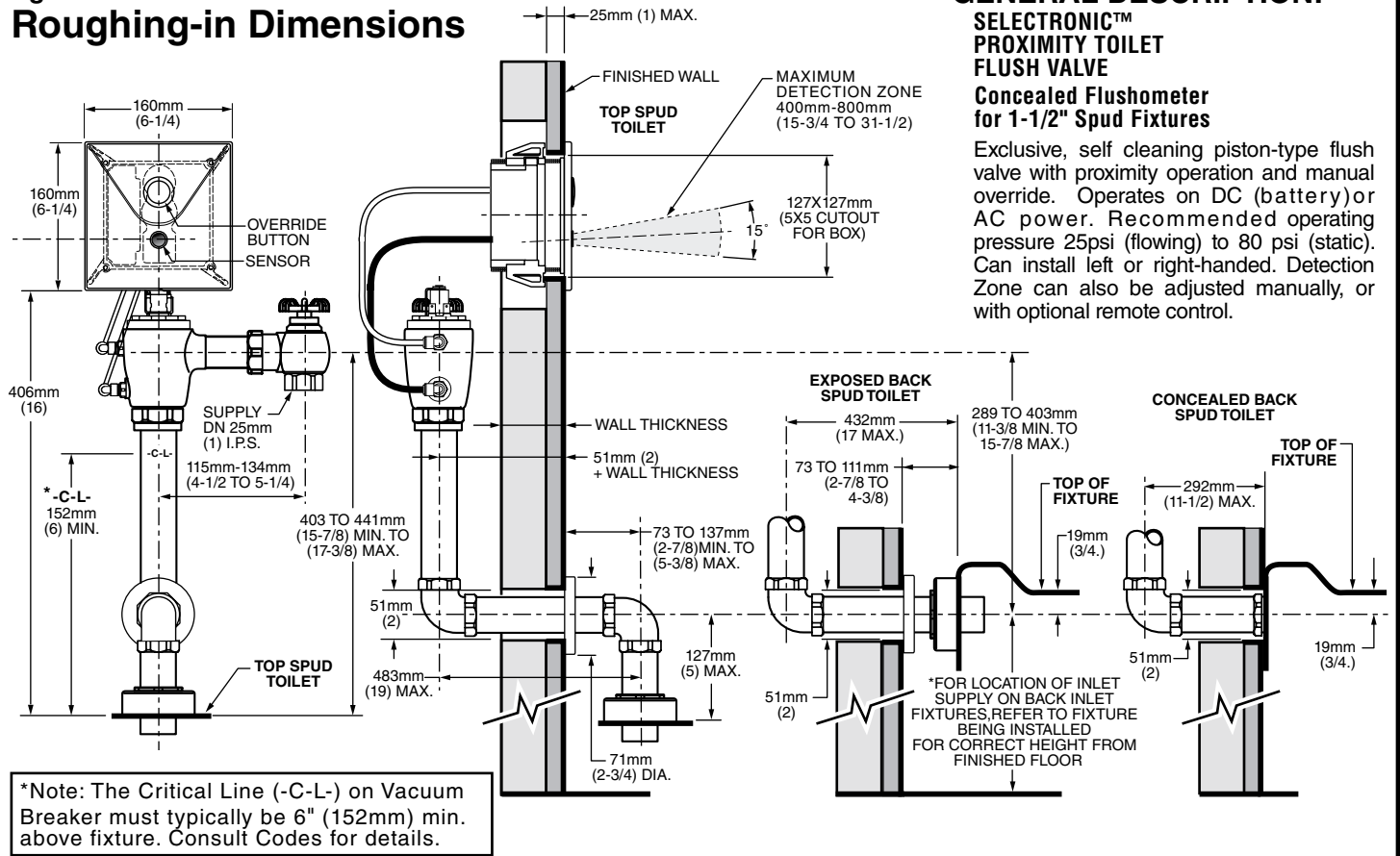
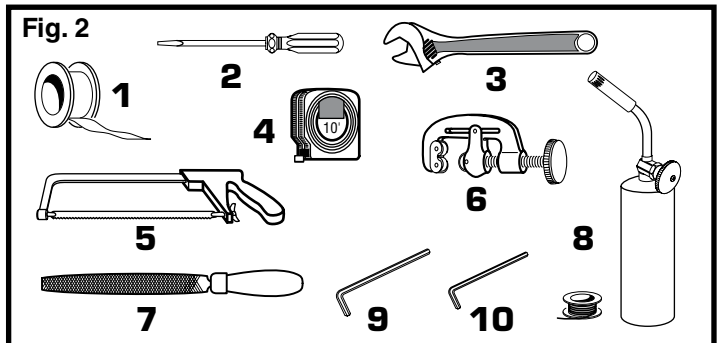

Fig. 1
Roughing-in Dimensions



RECOMMENDED TOOLS; Fig. 2

1. Teflon Tape
2. Flat Blade Screwdriver
3. Adjustable Wrench
4. Tape Measure
5. Hacksaw
6. Tubing Cutter
7. File
8. For Sweat Connection; Solder and Torch
9. 2.5mm Hex Wrench
10. 1.5mm Hex Wrench



PRIOR TO INSTALLATION

Note: Prior to installing the Selectronic™ Flush Valve the following items must be installed.

1. Water Closet
2. Drain line
3. Water supply line

IMPORTANT:

- All plumbing must be installed in accordance with applicable codes and regulations.
- Water supply lines must be sized to provide an adequate volume of water for each fixture.

- Flush all water lines prior to operation (**See Step 4**). Dirt and debris can cause flush valve to run continuously.
- With the exception of Supply Stop Inlet, **DO NOT** use pipe sealant or plumbing grease on any valve component or coupling!
- Protect the chrome or special finish on chrome plated items. **DO NOT USE** toothed tools on finished surfaces to install or service these valves. Also see "Care and Cleaning" section of this manual.
- This product contains mechanical and/or electrical components that are subject to normal wear. These components should be checked on a regular basis and replaced as needed to maintain the valve's performance.

1 INSTALL ELECTRICAL BOX ASSEMBLY; Fig. 3

1. Cut a 127x127mm (5"x 5") opening in finished wall for ELECTRICAL BOX (1) at the deminsion shown in Fig.3.

2. Rotate the 4 MOUNTING TABS (2) flat against the electrical box. Holding the MOUNTING TABS (2) in position install the ELECTRICAL BOX (1) into the opening. Make sure the MOUNTING TABS (2) are behind the wall.

3. Tighten the the 4 MOUNTING SCREWS (3) until the ELECTRICAL BOX (1) is almost secure in the wall. Before tightening fully rest a level at the top edge of the ELECTRICAL BOX (1) and make sure the box is level, then tighten fully. Fig. 3a.

4. *Cut a 2" hole for supply to fixture at deminsion shown.

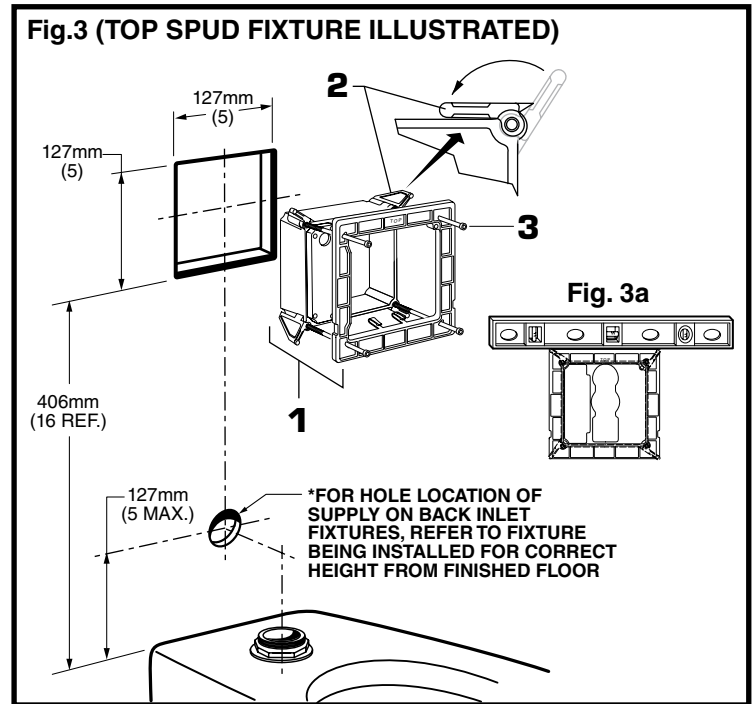

2 INSTALL SWEAT SOLDER ADAPTER; Fig. 4

CAUTION Turn water supplies off before beginning

Note: Control stop inlet is 1" IPS. For optional sweat connection, *install Sweat Solder Adapter (1) (Supplied) for 1" copper pipe supply line.* Fig. 4.

1. Clean the end of the supply pipe. Push the threaded ADAPTER (1) on until it is seated against the internal stop. Sweat the ADAPTER (1) to the pipe.

2. From behind the wall install the CONTROL STOP (2) to the water supply line with the outlet positioned as required.

3. Support piping as required.

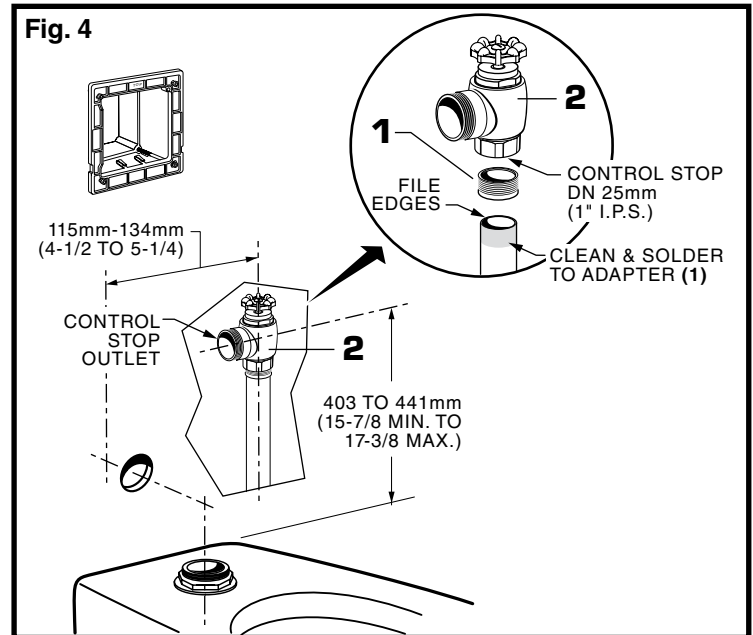

3 FLUSH OUT SUPPLY LINES; Fig. 5

1. Open SUPPLY STOP (1).

3. Turn on water supply to flush line of any debris or sediment.

4. Close SUPPLY STOP (1) and turn off water supply line.

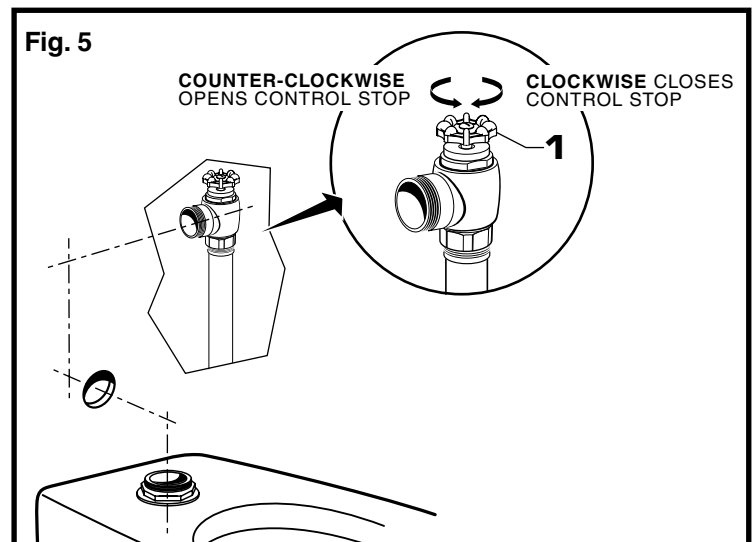

4 INSTALL VACUUM BREAKER AND FLUSH CONNECTIONS; Fig. 6

1. Place the SPUD FLANGE (1) over the spud on the Fixture. Fig. 6.

2. Thread SPUD COUPLING NUT (2) onto Spud. Make sure SEAL WASHER (4) and FRICTION WASHER (3) are installed. Do not tighten fully. Fig. 6.

3. Remove the COUPLING NUTS (6, 6a) from the CHROME ELBOW (5). Make sure you have a TAPERED RUBBER WASHER (7), PLASTIC SUPPORT (8) and SQUARE SEAL WASHER (9). Fig. 6a.

4. Install the SQUARE SEAL WASHER (9) onto the PLASTIC SUPPORT (8) if not already installed. Insert the PLASTIC SUPPORT (8) into the DOWN TUBE (10). Slide the COUPLING NUT (6) onto the DOWN TUBE (10). Connect the COUPLING NUT (6) to the CHROME ELBOW (5) and tighten fully. Insert the DOWN TUBE (10) with CHROME ELBOW (5) into the SPUD COUPLING NUT (2) and push it down. Do not tighten fully. Fig. 6a. **Note: If center line of ELBOW (5) cannot be adjusted to line up with hole in wall, then cut the DOWN TUBE (10) as required.**

5. Measure and cut the HORIZONTAL TUBE (11) to length required. **Important: Make sure that there is a minimum of 1-1/4" for engagement with elbow when making your measurement.** Fig. 6b.

6. Remove the COUPLING NUT (14) from BRASS ELBOW (12) and slide it onto the HORIZONTAL TUBE (11). Install the SQUARE SEAL WASHER (13) onto the PLASTIC SUPPORT (15) if not already installed. Insert the PLASTIC SUPPORT (15) into the HORIZONTAL TUBE (11). Connect the COUPLING NUT (14) to the BRASS ELBOW (12) and tighten fully. Fig. 6b.

7. From behind the wall install the ELBOW AND TUBE ASSEMBLY (12, 11) through the hole in the wall. Install WALL ESCUTCHEON (16) onto HORIZONTAL TUBE (11). Assemble the COUPLING NUT (6a) and TAPERED RUBBER WASHER (7) in the CHROME ELBOW (5) onto the HORIZONTAL TUBE (11). Push the HORIZONTAL TUBE (11) into the CHROME ELBOW (5). Tighten COUPLING NUT (6a) but not fully. Fig. 6b.

8. **For back spud installations:** Follow steps #1 and #2 to install the spud coupling kit. Push the HORIZONTAL TUBE (11) into the spud connection on the back of the fixture. Do not tighten fully. If spud coupling kit is not required install HORIZONTAL TUBE (11) into back spud on fixture and hand tighten. Fig. 6b.

9. **All installations:** If required cut scored VACUUM BREAKER PIPE (17) to fit, leave a minimum of 1-1/4" (32mm) of pipe to ensure engagement with compression coupling. Assemble the COUPLING NUT (18) and TAPERED RUBBER WASHER (19) in the BRASS ELBOW (12) onto the VACUUM BREAKER PIPE (17). Install VACUUM BREAKER PIPE (17) into BRASS ELBOW (12) and hand tighten COUPLING NUT (18). Fig. 6c.

Note: If cutting VACUUM BREAKER PIPE (16) to size, note that Critical Line (C/L) on Vacuum Breaker must typically be 6" (152mm) above fixture. Consult Code for details.

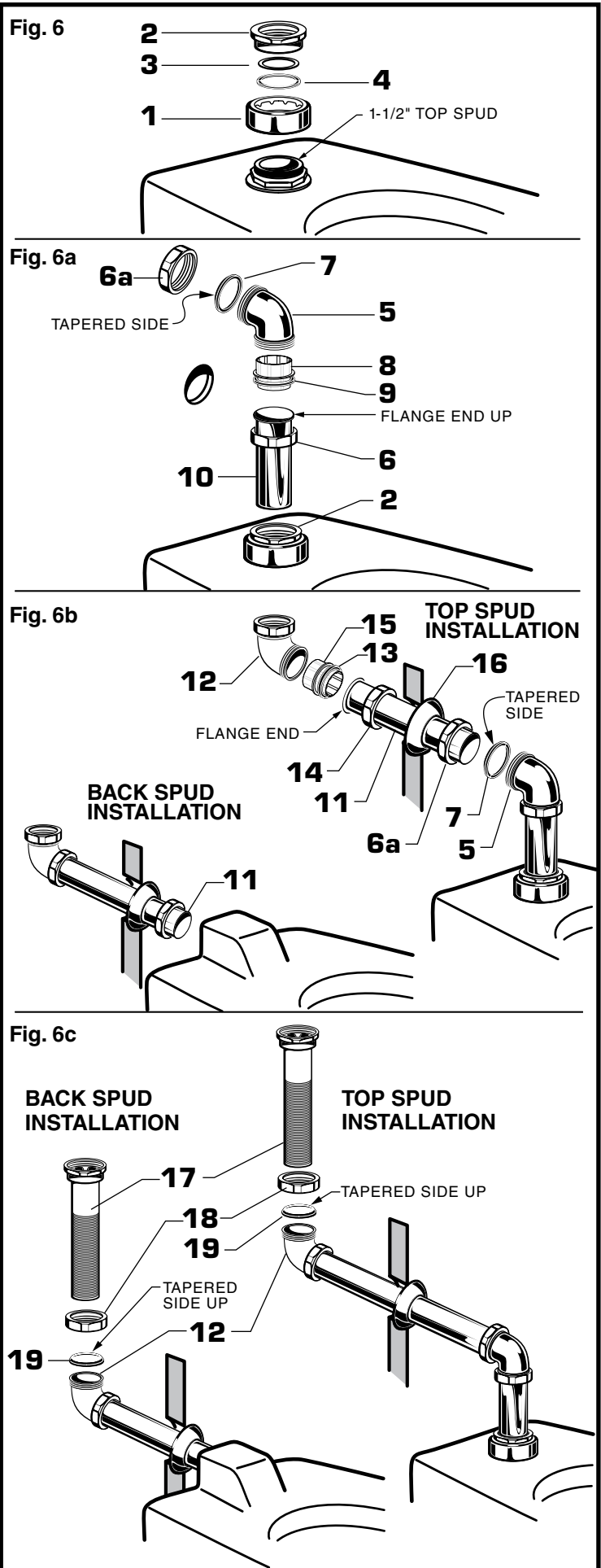

5 INSTALL FLUSH VALVE; Fig. 8

1. Insert the side ADJUSTABLE TAILPIECE (1) on the FLUSH VALVE (2) into the SUPPLY STOP (3). Lubricate the TAILPIECE O-RING (4) with water if necessary. Lightly tighten COUPLING NUT (5). **Fig. 8.** **Important: Do not use lubricants (other than water) or any type of thread sealing paste or tape.**

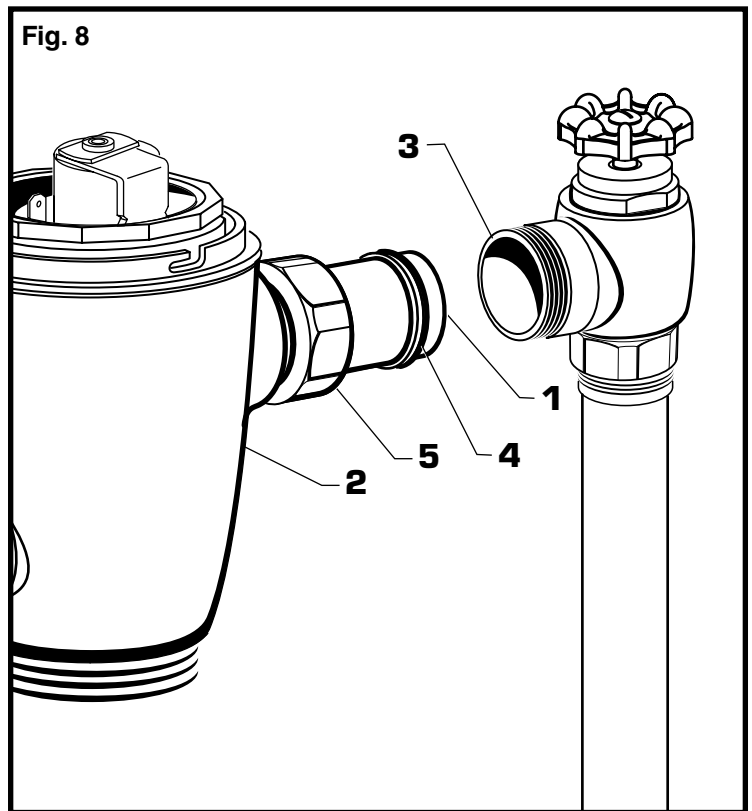

6 CONNECT FLUSH VALVE TO PIPING; Fig. 9

1. Align the FLUSH VALVE (2) (Fig. 9) directly above the VACUUM BREAKER TUBE (7) and VACUUM COUPLING NUT (6). Make sure that GASKET (10) is installed.

Note: There is a +13mm, -6mm (+1/2, -1/4) tolerance for the 121mm (4-3/4) dimension. Fig. 9.

2. Pull the VACUUM BREAKER TUBE (7) up to meet the threaded FLUSH VALVE CONNECTION (8) and hand tighten the COUPLING NUT (6). Align all components of the flush valve assembly. **Fig. 9.**

3. Lightly tighten the TAILPIECE COUPLING NUT (5) connection first, then the VACUUM BREAKER COUPLING NUT (6) and finally the SPUD COUPLING NUT (9). Once aligned correctly, use a wrench to tighten all couplings to make water tight connections. **Fig. 9.**

4. Secure piping behind wall as required.

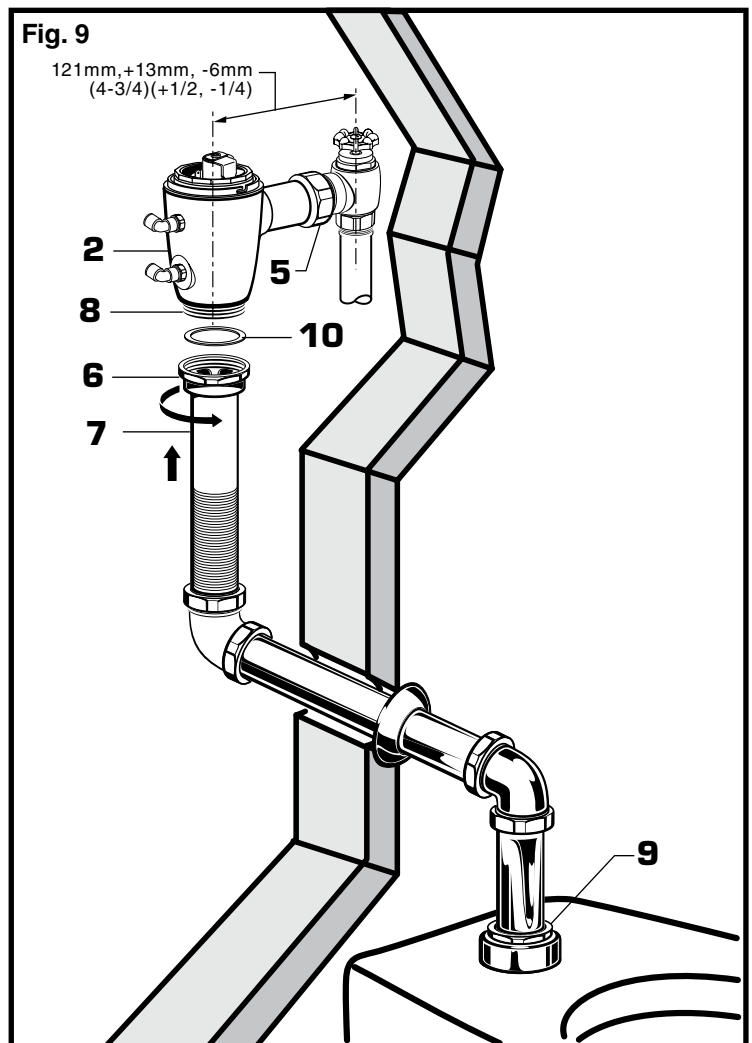

7 CONNECT FRONT PANEL TO ELECTRICAL BOX (AC POWER);

Fig. 10

1. Remove the four COVER SCREWS (1) and COVER from (2) ELECTRICAL BOX (4). Fig. 10.

2. Pull the CIRCUIT BOARD (3) out from ELECTRICAL BOX (4). Fig. 10.

3. Knock out lower blank in ELECTRICAL BOX (4) with flat blade screwdriver. Install from the back of ELECTRICAL BOX (4) the POWER SUPPLY GROMMET (8). Fig. 10a.

4. Attach the SAFETY CHAIN (5) from the FRONT PANEL (6) to the MOUNTING POST (7) as shown. Feed the Red and Black wires through the back opening in the ELECTRICAL BOX (4). Fig. 10a.

5. From back of ELECTRICAL BOX (4) remove SPLIT PLUG (8a) from POWER SUPPLY GROMMET (8). Insert POWER CORD CONNECTOR (9) through POWER SUPPLY GROMMET (8). Insert POWER CORD (10) into SPLIT PLUG (8a). Push SPLIT PLUG (8a) into POWER SUPPLY GROMMET (8) to seal. Fig. 10b.

6. Insert POWER SUPPLY CONNECTOR (9) into RECEPTOR (11) on CIRCUIT BOARD (3). Install CIRCUIT BOARD (3) into ELECTRICAL BOX (4). Fig. 10b.

7. Install the SENSOR WIRE GROMMET (15) into the COVER (2) as shown. Remove the SPLIT PLUG (15a) from SENSOR WIRE GROMMET (15). Insert SENSOR WIRE CONNECTOR (12) through SENSOR WIRE GROMMET (15). Insert SENSOR WIRE (13) into SPLIT PLUG (15a). Push SPLIT PLUG (15a) into SENSOR WIRE GROMMET (15) to seal. Fig. 10c.

8. Insert SENSOR WIRE CONNECTOR (12) into CIRCUIT BOARD RECEPTOR (14) slot. Fig. 10c.

9. Replace COVER (2). Tighten COVER SCREWS (1) firmly.

Fig. 10

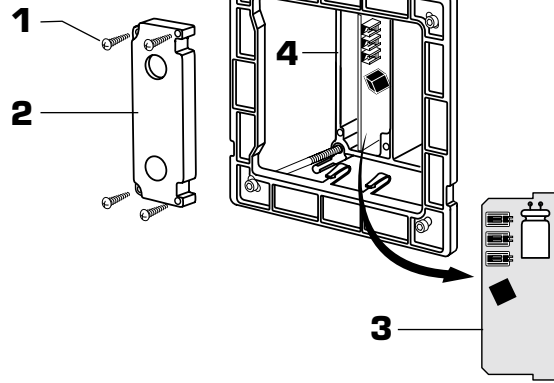

Fig. 10a

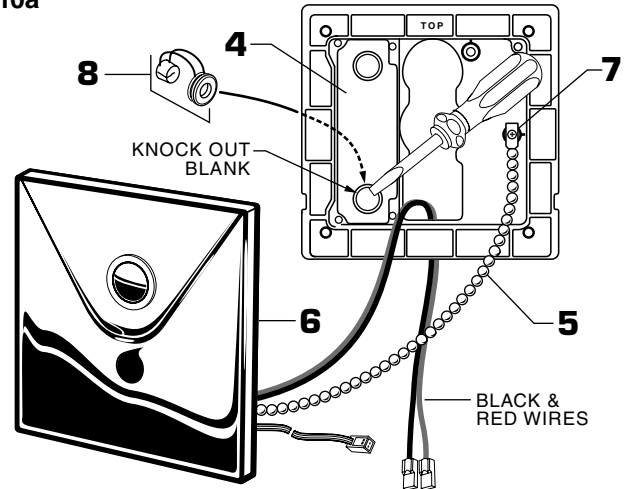

Fig. 10b

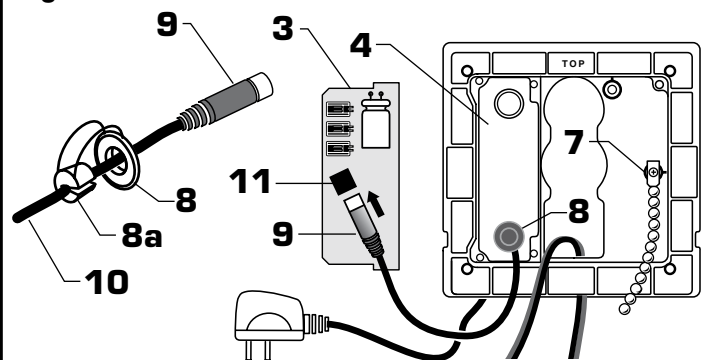
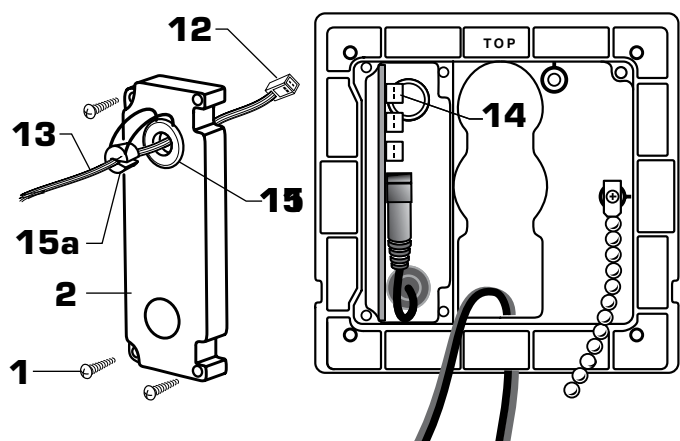

Fig. 10c



8 CONNECT FRONT PANEL TO ELECTRICAL BOX (DC POWER BATTERY); Fig. 11

1. Remove the four COVER SCREWS (1) and COVER (2) from ELECTRICAL BOX (3). Fig. 10.

2. Install BATTERY (4) into holder on DC circuit board. Press BATTERY (4) down (contacts facing downward) into position until tabs lock BATTERY (4) into place.

3. Attach the SAFETY CHAIN (5) from the FRONT PANEL (6) to the MOUNTING POST (7) as shown. Feed the Red and Black wires through the back opening in the ELECTRICAL BOX (3). Fig. 11a.

4. Install the SENSOR WIRE GROMMET (11) into the COVER (2) as shown. Remove the SPLIT PLUG (11a) from SENSOR WIRE GROMMET (11). Insert SENSOR WIRE CONNECTOR (8) through SENSOR WIRE GROMMET (11). Insert SENSOR WIRE (9) into SPLIT PLUG (11a). Push SPLIT PLUG (11a) into SENSOR WIRE GROMMET (11) to seal. Fig. 11b.

8. Insert SENSOR WIRE CONNECTOR (8) into CIRCUIT BOARD RECEPTOR (10) slot. Fig. 11b.

9. Replace COVER (2). Tighten COVER SCREWS (1) firmly.

Fig. 11

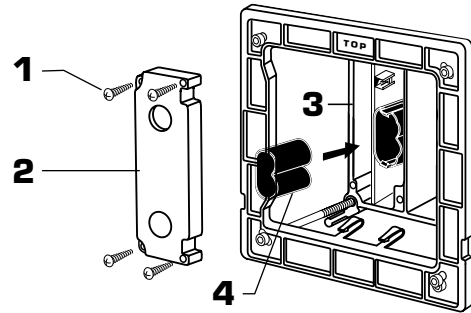

Fig. 11a

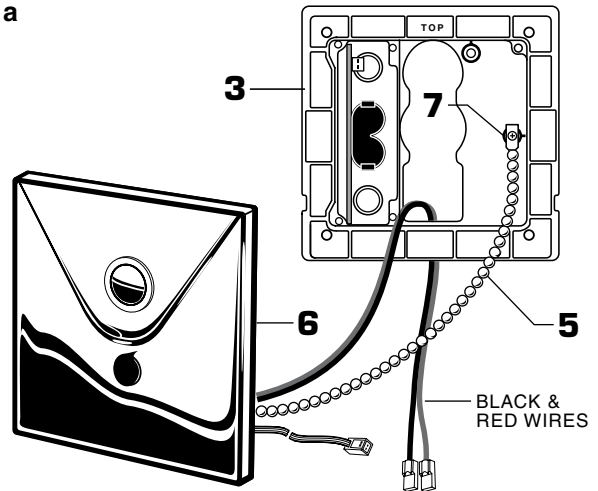
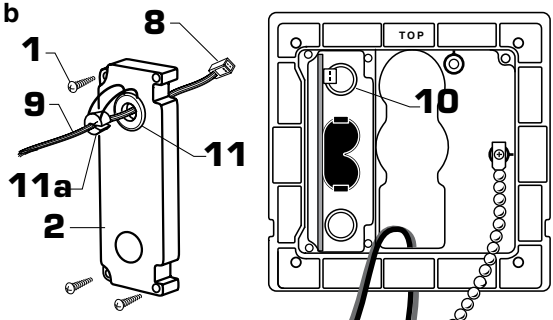

Fig. 11b



9 INSTALL FRONT PANEL; Fig. 12

1. Install the two TABS (1) on the back side of FRONT PANEL (2) into the two SLOTS (3) located on the top edge of the ELECTRICAL BOX (4). Fig. 12.

2. Push on the bottom edge of the FRONT PANEL (2) until it snaps into place. If FRONT PANEL (2) will not snap into place, then loosen the MOUNTING SCREWS (6) on the ELECTRICAL BOX (4) slightly. Fig. 12.

3. To remove FRONT PANEL (2) insert WIRE KEY (5) (supplied) into the two holes located at the bottom of the FRONT PANEL (2). Push the WIRE KEY (5) up until it releases the bottom clips. Pull the bottom edge away and lift the FRONT PANEL (2) off. Fig. 12.

Fig. 12

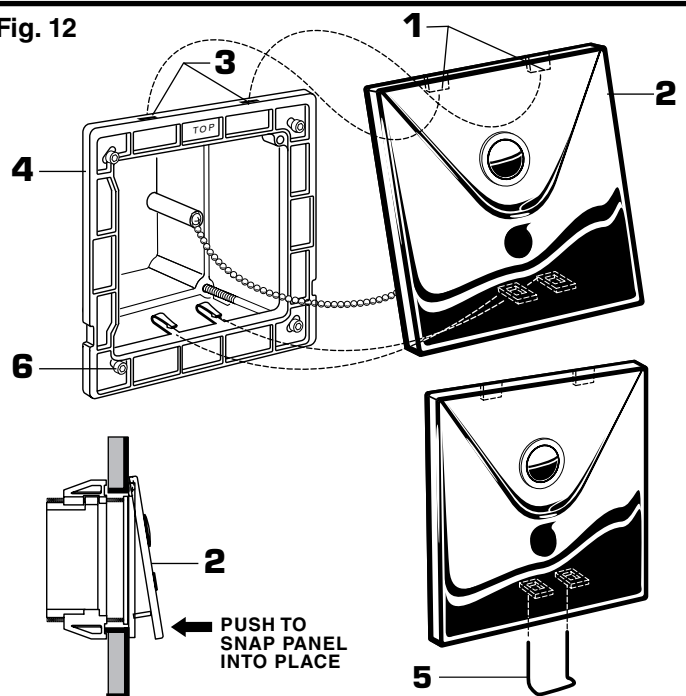

10 CONNECT OVERRIDE HOSES, AC & DC POWER; Fig. 13

1. Push the BLACK HOSE (1) into the BOTTOM HOSE CONNECTOR (2) and the other end into the back of the OVERRIDE SWITCH (3).

2. Push the BLUE HOSE (4) into the TOP HOSE CONNECTOR (5) on the valve and the other end into the BOTTOM CONNECTOR (6) on the OVERRIDE SWITCH (3).

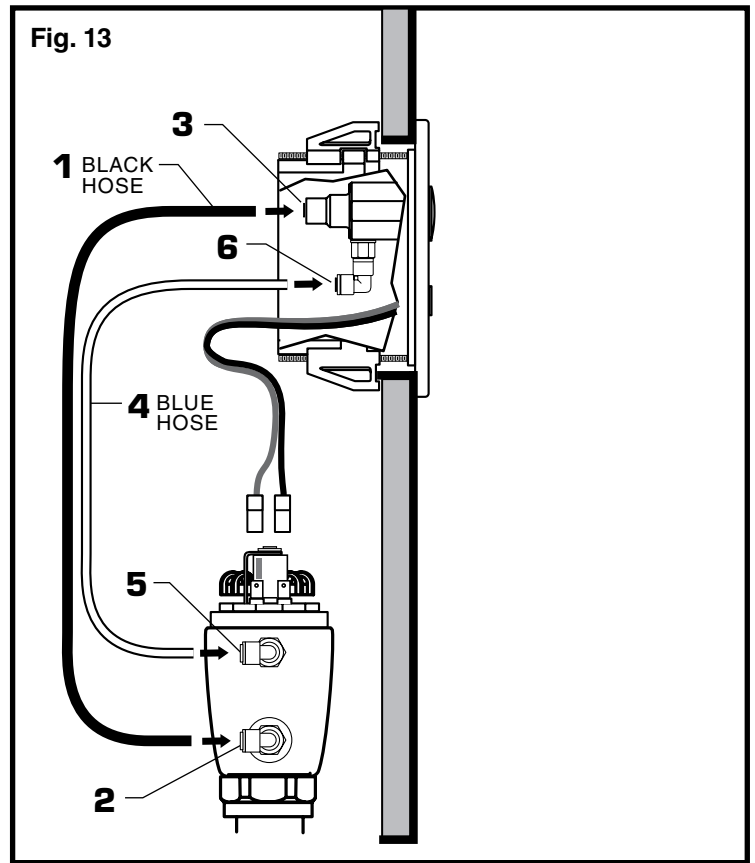

11 CONNECT SOLENOID WIRING AND POWER SUPPLY; Fig. 14

1. Push the RED WIRE CONNECTOR (1) onto the SOLENOID PIN (2) with Red Stripe. Push the BLACK WIRE CONNECTOR (3) onto the other SOLENOID PIN (4). Push the wire connectors all the way down.

2. Code approved Electrical Outlet provided by others, (120V 50/60 Hz).

3. Plug AC POWER SUPPLY (5) into Outlet.

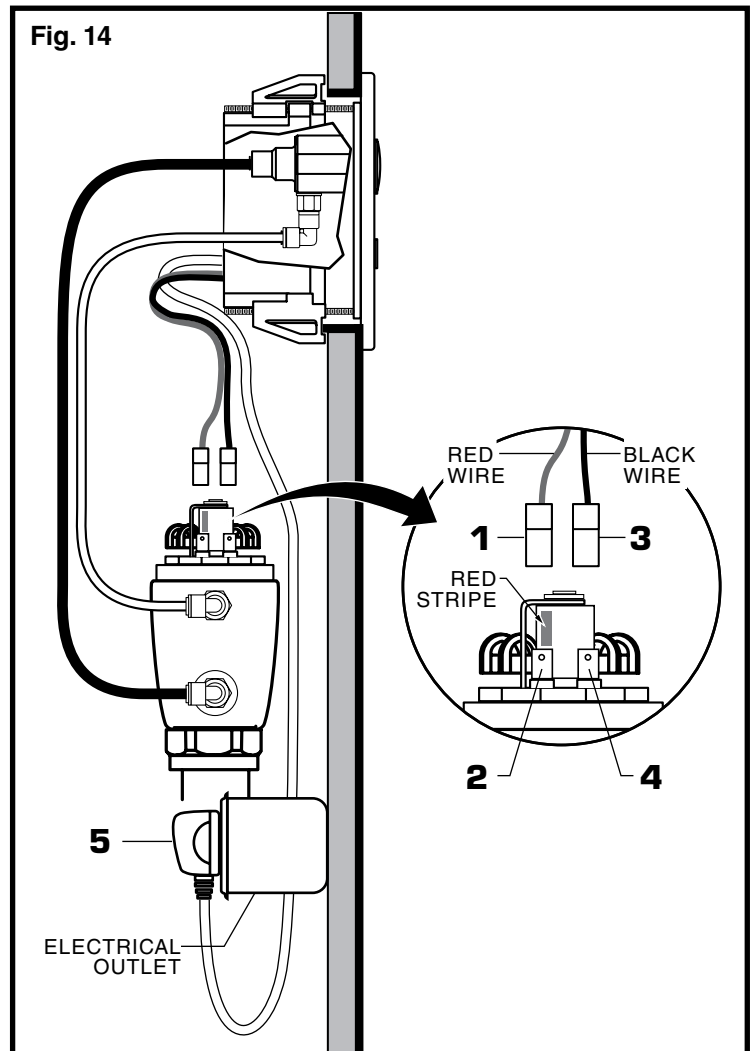
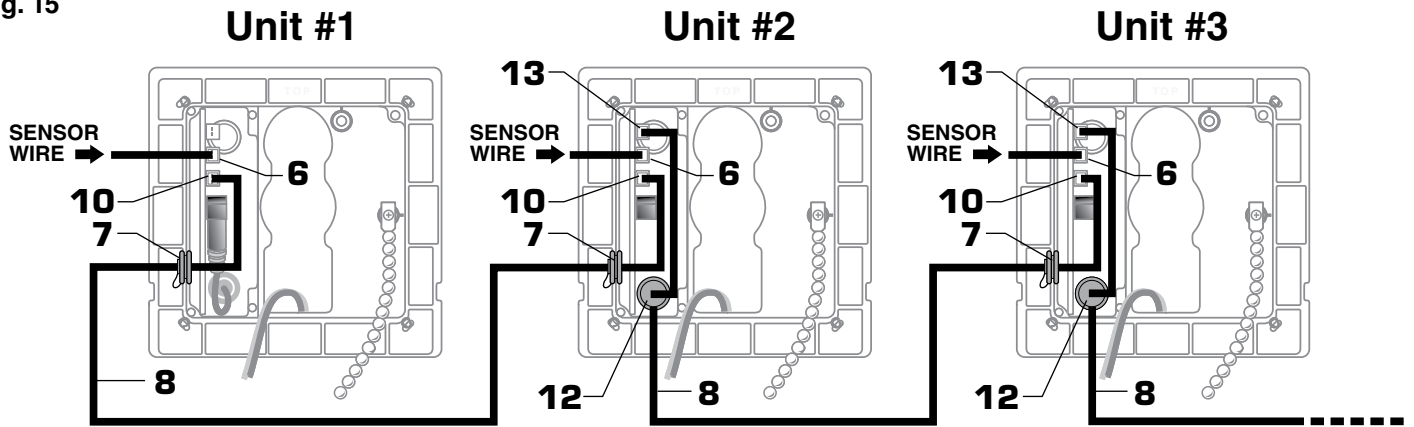

Fig. 15



12 FOR AC-VERSION (MULTI HOOK-UP); Fig. 15, 15a

1. Remove the COVER SCREWS (1) and COVER (2) from each ELECTRICAL BOX (3).
2. See AC Version Electrical Hook-up for Unit #1 of the Multi hook-up.
3. Install SENSOR WIRE GROMMET (4) and FLUSH VALVE SENSOR WIRE (5) into the COVER (2) of each unit. Insert the flush valve sensor wire connector into the CENTER CIRCUIT BOARD RECEPTOR (6) on each unit. Fig. 15a.
4. Remove the SPLIT PLUG (7a) from the SENSOR WIRE GROMMET (7) on the left side of each ELECTRICAL BOX (3).
5. Take the 10 ft. EXTENSION WIRE (8) from Unit #2 and insert one end of the EXTENSION WIRE CONNECTOR (9) through the SENSOR WIRE GROMMET (7) on left side of Unit #1. Insert EXTENSION WIRE (8) into SPLIT PLUG (7a). Push SPLIT PLUG (7a) into SENSOR WIRE GROMMET (7) to seal. Insert EXTENSION WIRE CONNECTOR (9) into LOWER CIRCUIT BOARD RECEPTOR (10). Fig. 15a.
6. Insert other end of EXTENSION WIRE (8) into SENSOR WIRE GROMMET (7) on left side of Unit #2. Insert that EXTENSION WIRE CONNECTOR (9) into the LOWER CIRCUIT BOARD RECEPTOR (10) of Unit #2. Fig. 15b.
7. On Unit #2 ELECTRICAL BOX (3) remove ROUND KNOCK-OUT (11) on the bottom of the box by pressing a flathead screwdriver into the center of the ROUND KNOCK-OUT (11). Fig. 15b.
8. Insert additional SENSOR WIRE GROMMET (12) included with Unit #2 into the knock-out opening in the bottom of the ELECTRICAL BOX (3). Take the 10 FT. EXTENSION WIRE (8) from Unit #3 and insert one end into the SENSOR WIRE GROMMET (12) in the bottom of the ELECTRICAL BOX (3) of Unit #2. Insert EXTENSION WIRE CONNECTOR (9a) into TOP CIRCUIT BOARD RECEPTOR (13) on Unit #2. Fig. 15b.
9. Insert the other end of the EXTENSION WIRE (8) from Unit #3 into the SENSOR WIRE GROMMET (7) on the left side of Unit #3. Insert EXTENSION WIRE CONNECTOR (9) into LOWER CIRCUIT BOARD RECEPTOR (10) on Unit #3.
10. Repeat Steps 7 to 9 as necessary for additional Multi-AC Units.
11. Once all wire connections are made. Install the COVER (2) and COVER SCREWS (1) onto each ELECTRICAL BOX (3).

Fig. 15a

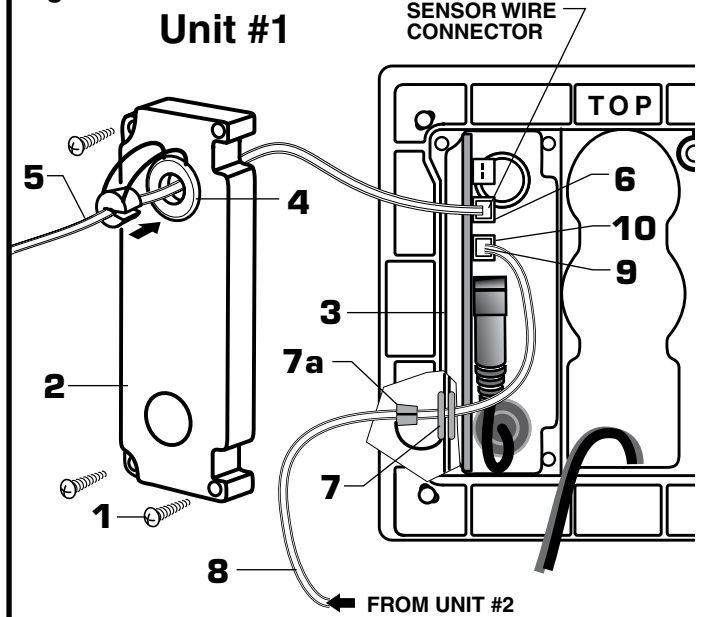
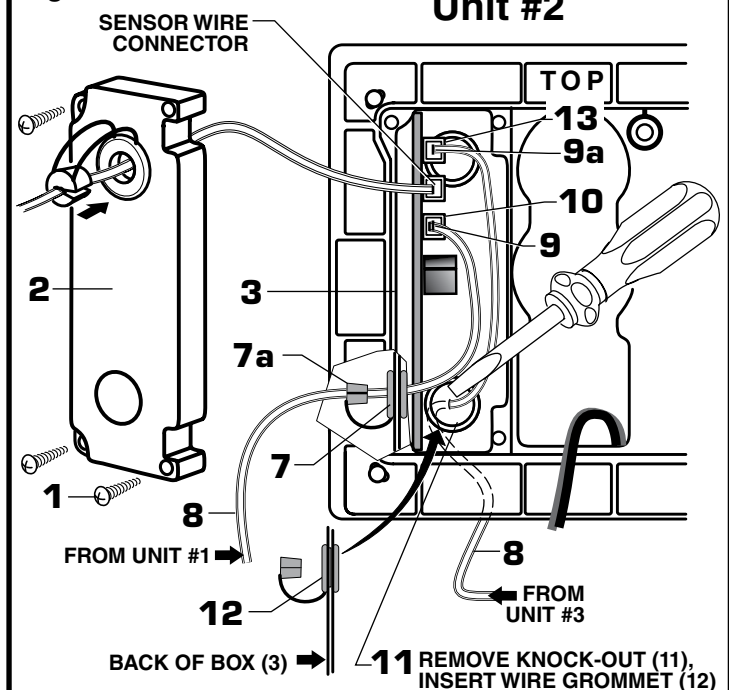

Fig. 15b



13 HOW TO INSTALL NEW BATTERY; Fig. 16

1. Remove FRONT PANEL. *For removing front panel see Step 9 for instructions.*
2. Remove the four COVER SCREWS (1) and COVER (2) from ELECTRICAL BOX (3). Fig. 16.
3. Disconnect GREY SENSOR WIRE (4) from CIRCUIT BOARD (5).
4. Remove CIRCUIT BOARD (5) from ELECTRICAL BOX (3). Fig. 16a.
5. With your thumbs, spread the two TABS (6) on battery holder apart and remove the BATTERY (7).
2. Install NEW BATTERY (7) into holder on DC circuit board. Press BATTERY (7) down (contacts facing downward) into position until TABS (6) lock BATTERY (7) into place.
6. Install CIRCUIT BOARD (5) and connect GREY SENSOR WIRE (4).
7. Install COVER (2) and SCREWS (1).
8. Replace and FRONT PANEL. *See Step 9 for instructions on installing front panel.*

Fig. 16

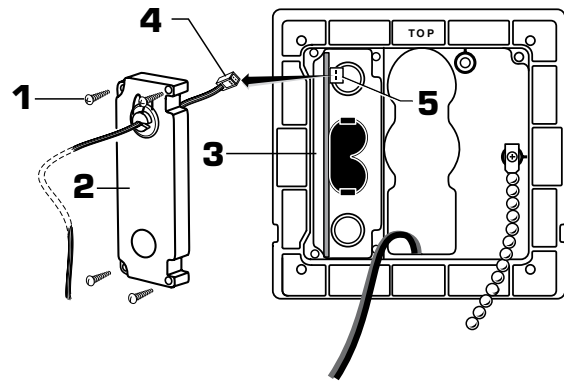
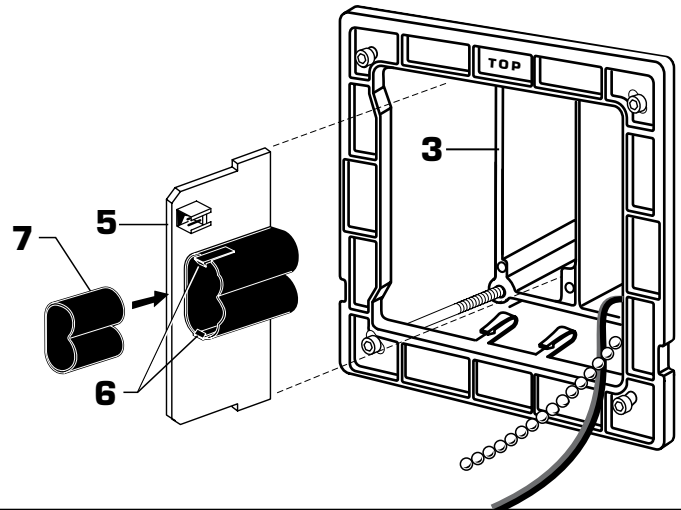

Fig. 16a



14 ADJUST SUPPLY STOP; Fig. 17

IMPORTANT: To avoid overflowing, the SUPPLY STOP (2) must never be opened to the point where the flow from the valve exceeds the flow capacity of the fixture. The fixture must be able to handle a continuous flow in case of a flush valve failure. Valve is designed to provide stated flush volume with a 25 GPM flow rate.

1. After installation is complete, peel off the PROTECTIVE FILM (1) from the sensor. Standing to one side, block the sensor with your hand for 10 seconds. **Remove your hand and listen for audible "click" from within the valve.**
2. Turn on SUPPLY STOP (2) 1/4 turn to 1/2 turn (CCW) and test for leaks. **Note: Unit may flush for approximately 5 to 10 sec. when water is first turned on. If flow persists, turn water off and repeat step #1 above.**
3. Actuate the FLUSH VALVE:
 - A) Cover sensor with hand for 10 seconds. **NOTE: Stand outside of sensor detection area.**
 - B) Remove hand from in front of the sensor; unit will flush in approximately 3 seconds.
4. Adjust SUPPLY STOP (2) after each flush until the stated flush volume is achieved, no splashing occurs and the fixture is properly cleansed.

Fig. 17

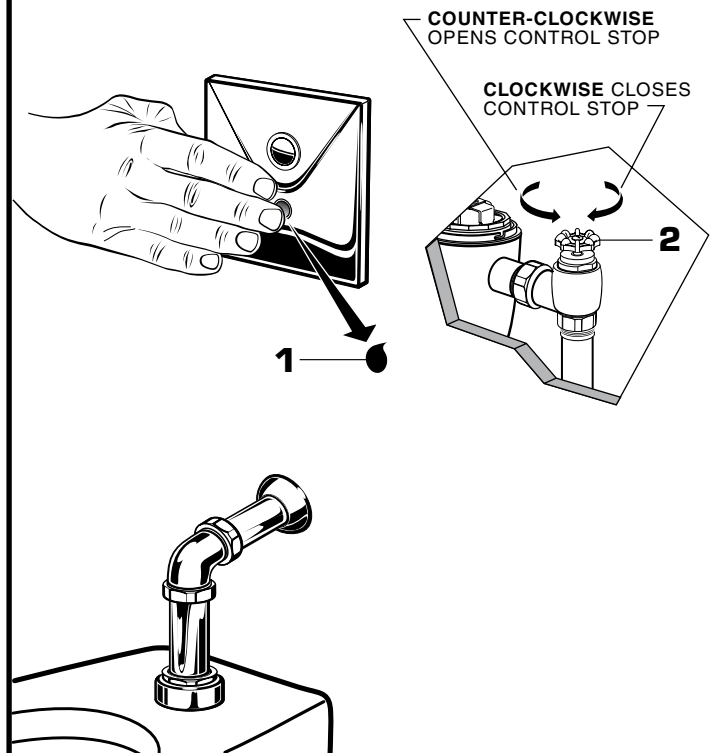

15 HOW TO SET DETECTION RANGE (If Required) ; Fig. 18 & 19

Note: The detection distance is preset and is ideal for most installations. Should an adjustment be required follow the steps below.

1. Remove FRONT PANEL (1). See Step 9 for removing front panel instructions.
2. Remove the four COVER SCREWS (2) and COVER (3) from ELECTRICAL BOX (4). Fig. 18.
3. Disconnect GREY SENSOR WIRE (5) from CIRCUIT BOARD. (6).
4. Keeping hands away from the front of the sensor, reconnect the GREY SENSOR WIRE (5) and quickly hang the FRONT PANEL (1) onto the ELECTRICAL BOX (4). Do not secure the FRONT PANEL (1) at this time. **Note: You have 5 seconds after connecting cable to begin program process.**
5. While the SENSOR CONTROL LED (6) is blinking slowly, place your hand 1 to 2 in. (30-50mm.) in front of the sensor. Fig. 19.
6. When the LED (6) stops blinking and stays "ON", move your hand to the desired position from sensor (detection zone, 15-3/4" to 31-1/2", 400 to 800mm) and hold in place until the LED (6) begins to blink again. Fig. 19a.
Note: Maximum Detection Zone is 15-3/4" to 31-1/2", (400 to 800mm) from sensor.
7. Once the SENSOR CONTROL LED (6) begins to blink again, remove your hand from the detection zone. When the flashing stops, the detection distance is set.
8. Replace COVER (3). Tighten COVER SCREWS (2) firmly.

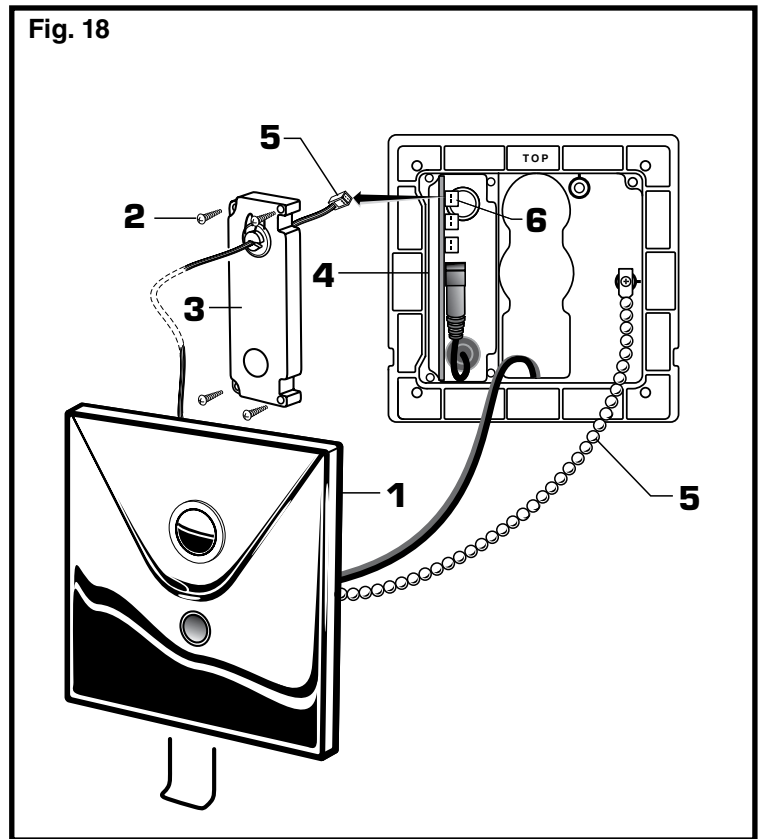

9. Replace the FRONT PANEL (1). See Step 9 for instructions on installing front panel.
10. Actuate the FLUSH VALVE:
 - A) Cover sensor with hand for 10 seconds. **NOTE: Stand outside of sensor detection area.**
 - B) Remove hand from in front of the sensor, unit will flush in approximately 3 seconds.

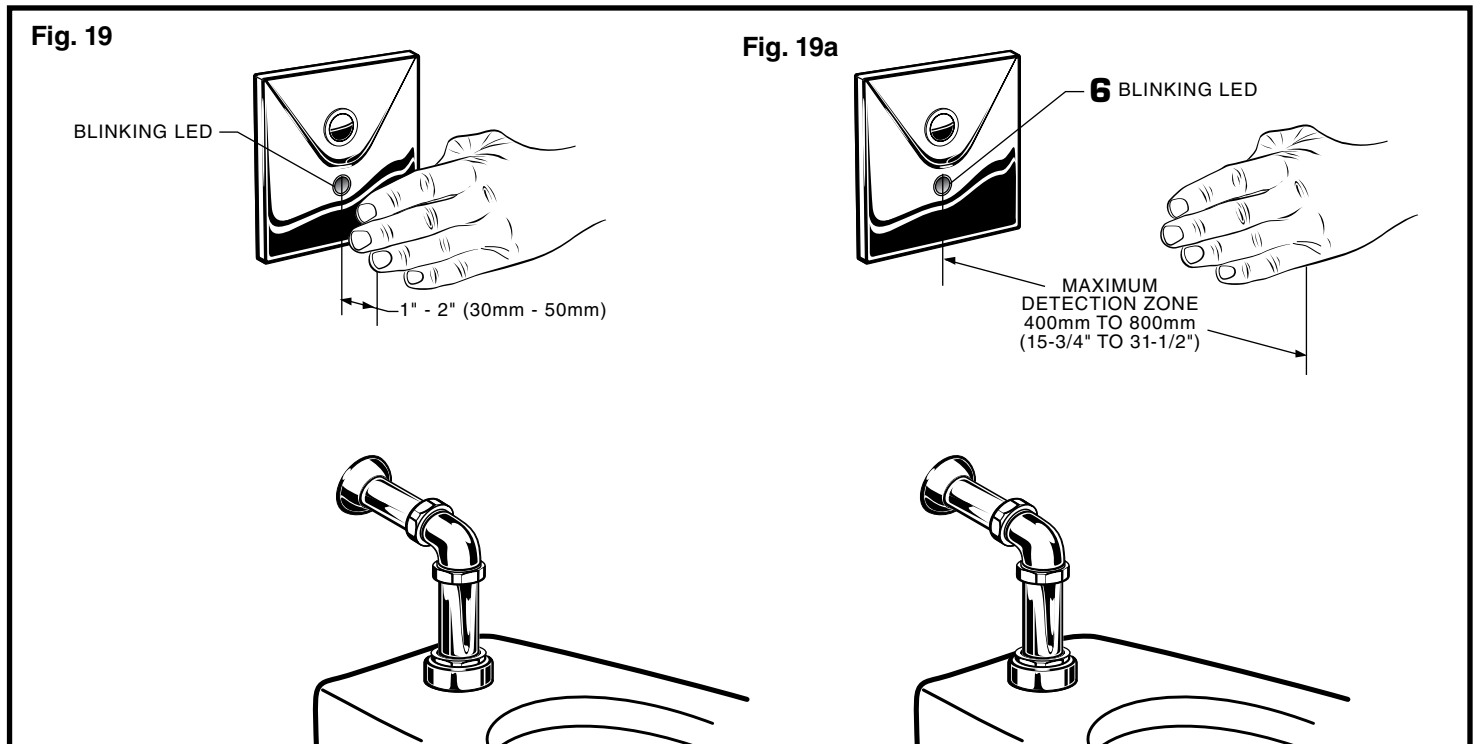

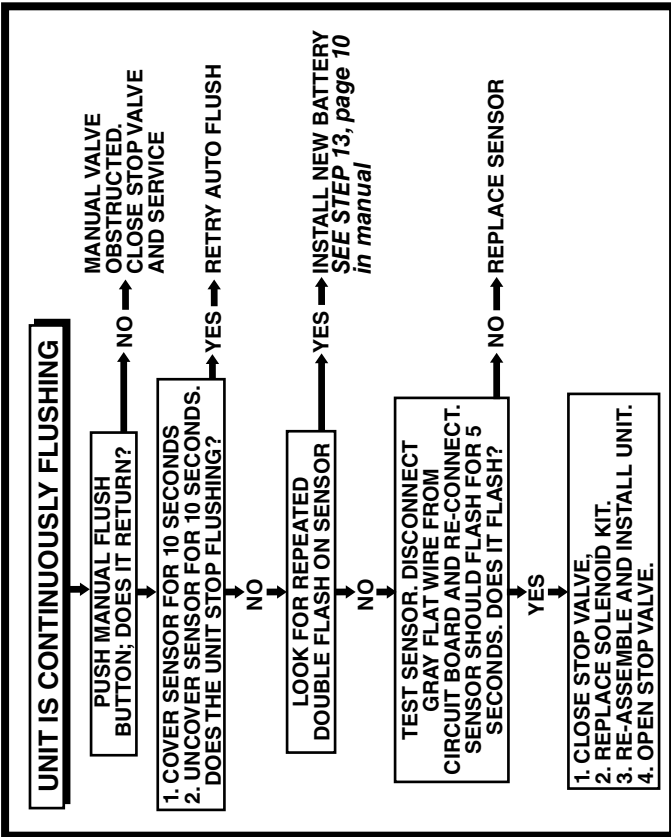
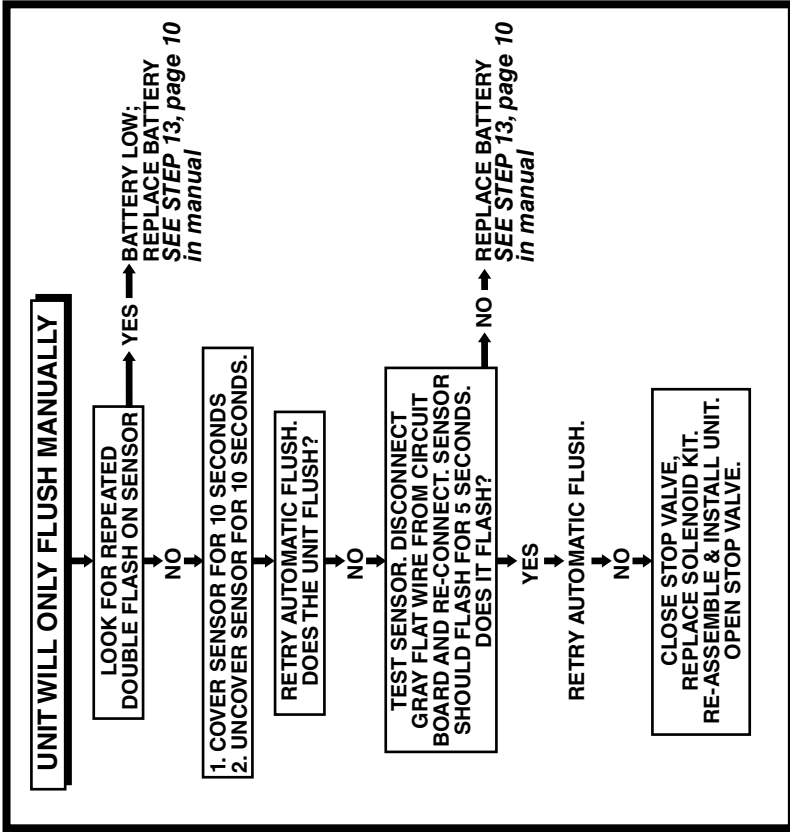
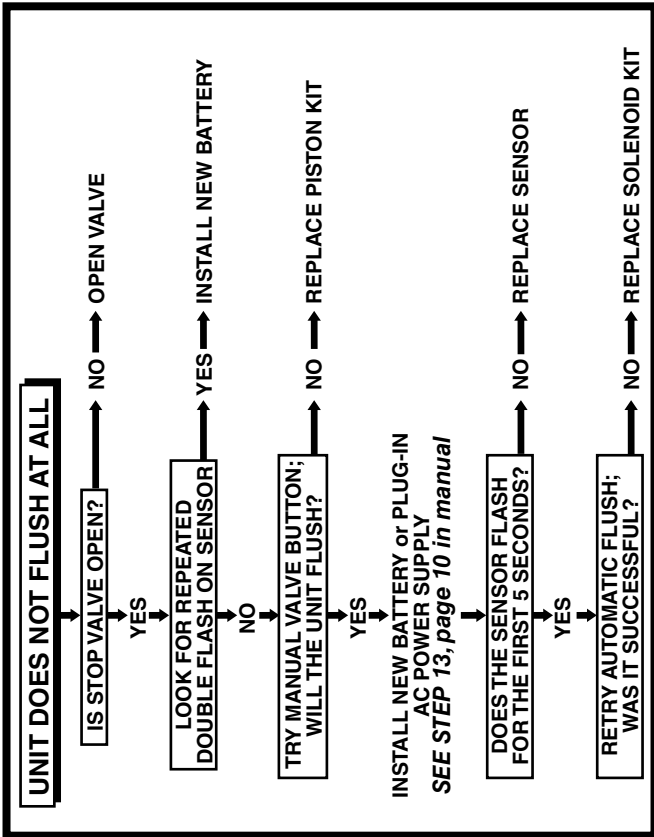

TROUBLESHOOTING FLOW CHARTS



HOT LINE FOR HELP
 For toll-free information and answers to your questions, call:
 1 (800) 442-1902
 Weekdays 8:00 a.m. to 6:00 p.m. EST
 IN MEXICO 01-800-839-12-00
 IN CANADA 1-800-387-0369 (TORONTO 1-905-306-1093)
 Weekdays 8:00 a.m. to 7:00 p.m. EST

Product names listed herein are trademarks of AS America, Inc.

SELECTRONIC™ PROXIMITY TOILET CONCEALED FLUSH VALVE 1.28 & 1.6 GPF

MODEL NUMBERS

6065.22X 6065.26X

6067.22X 6067.26X

6068.22X 6068.26X

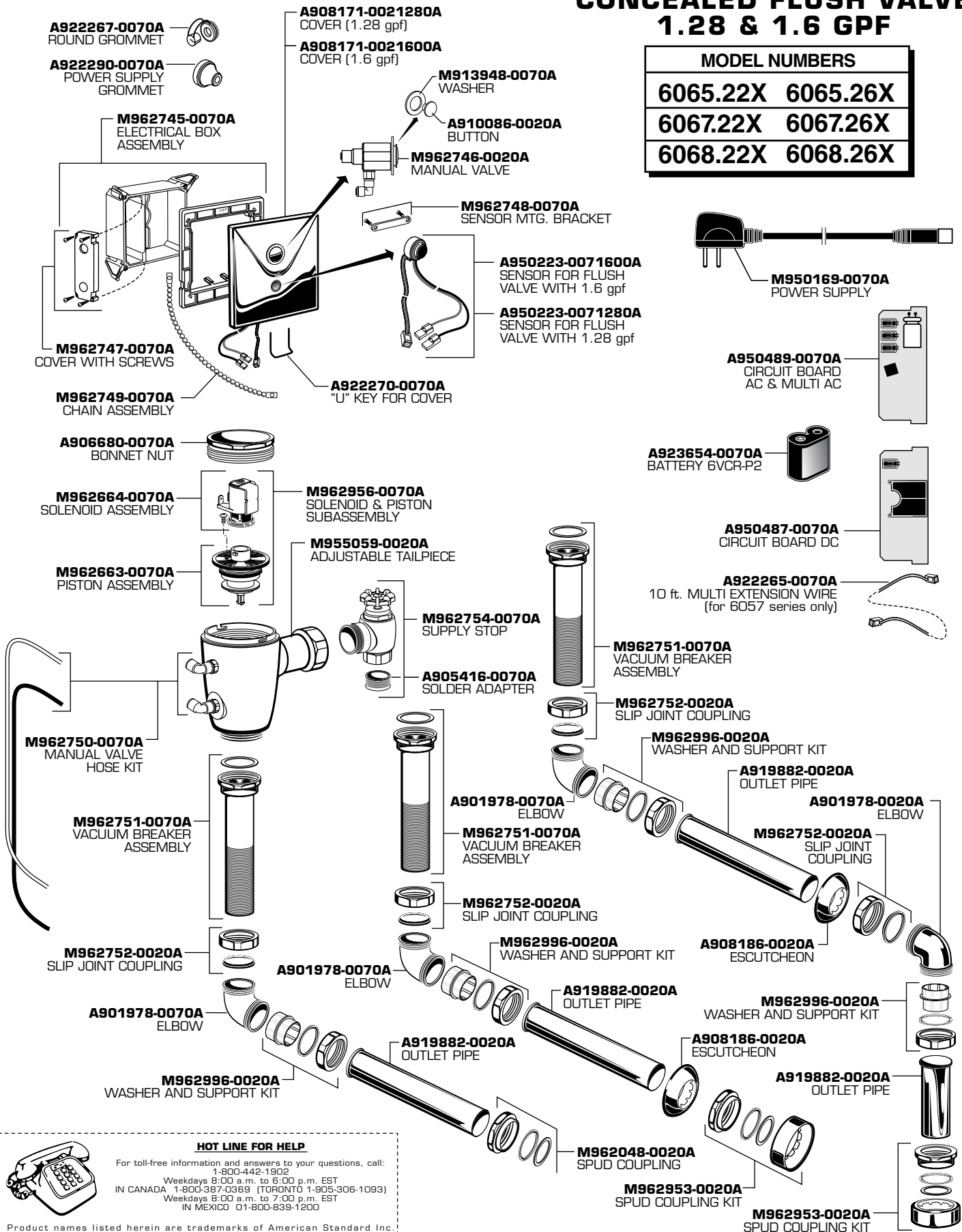

HOT LINE FOR HELP

For toll-free information and answers to your questions, call:
1-800-442-1902
Weekdays 8:00 a.m. to 6:00 p.m. EST
IN CANADA 1-800-387-0369 (TORONTO 1-905-306-1093)
Weekdays 8:00 a.m. to 7:00 p.m. EST
IN MEXICO 01-800-839-1200

Product names listed herein are trademarks of American Standard Inc.
© AS America, Inc. 2009