

SPECIFICATIONS

PARMA™ TRIM LINE SINGLE HANDLE LAVATORY FAUCET

Model

D228058

Description

- Ceramic disc valve
- 4" high spout, 5" spout length
- With drain assembly
- Hot and cold markings on handle
- Single hole mount
- A112.18.1M, 1.5 gpm (5.7 LPM) maximum flow rate @ 20 - 80 psi

Flow Rate

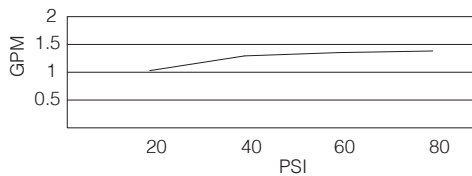

Standards



- NSF 61-9
- Energy Policy Act of 1992



NSF/ANSI 372

- ASME A112.18.1M/A112.18.1
- NSF/ANSI 372



- ADA Accessibility Guidelines for Buildings and Facilities - 4.27.4 Controls and Mechanisms

Finishes Available

- Chrome
- Other: Refer to Price List for additional finish

Warranty

Danze products are covered by a manufacturer's limited "lifetime" warranty for manufacturing defects.

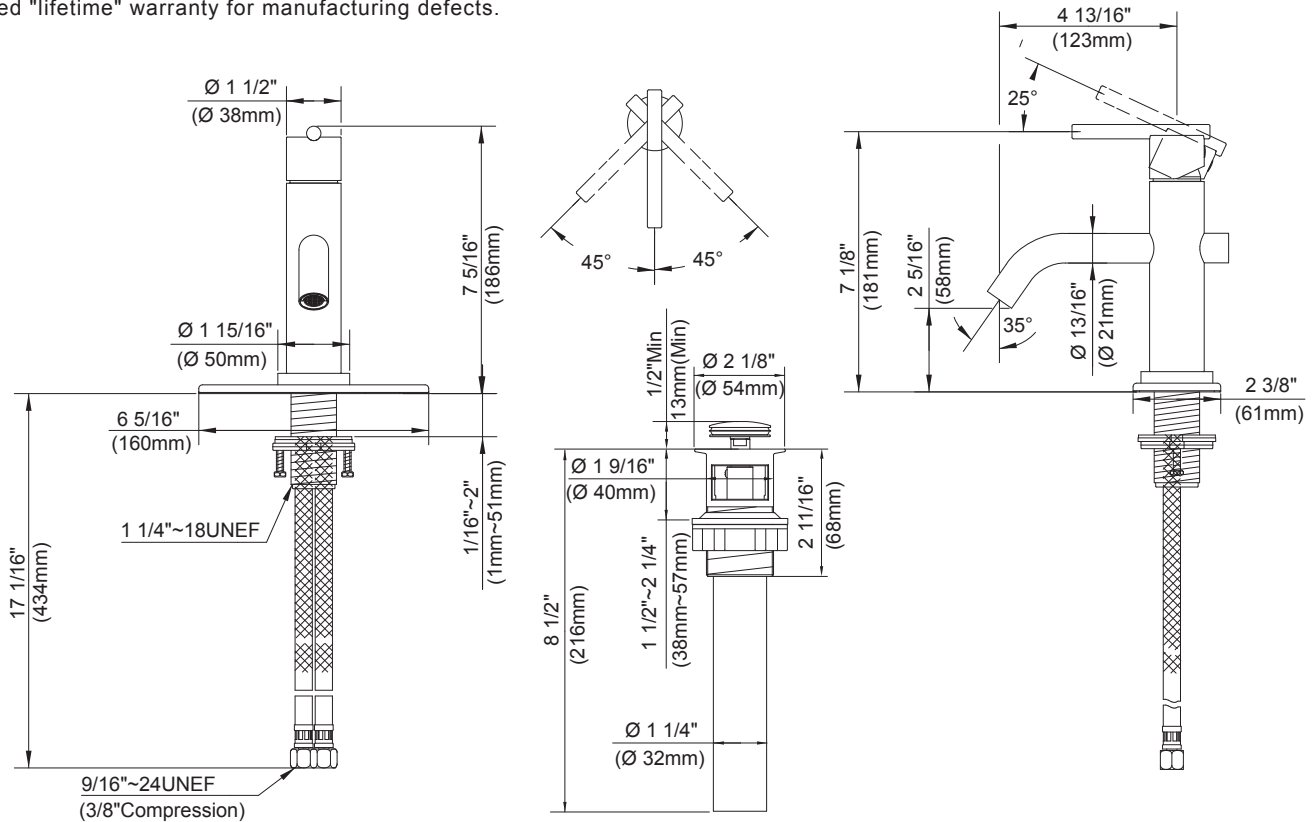

Submittal Information:

Job Name: _____
 Contractor: _____

Location: _____
 Contact #: _____