

SOLUTION
SERIES

TRK50B



GENERAL FEATURES

- 50" Wide TV Stand allows for mounting of most 50" and smaller Flat Panels.
- Swiveling Mount AND all mounting hardware included.
- Mount is rated for 150 pounds.
- 2 shelves with brilliant silkscreen black glass.
- Ultramodern, contemporary, SOLUTION!



**TECH
CRAFT**

TRK50B

	Carton dimensions	Gross Weight	Volume	UPC code
(h)	5 1/2" / 140mm	93.55 lbs / 45.5 kg	4.18 cu ft / 0.12 cu m	6-23788-00414-7
(w)	23" / 584mm	Dimension and weight / volume information on this sheet is rounded. Specifications subject to change without notice.		
(d)	51 1/4" / 1301mm			

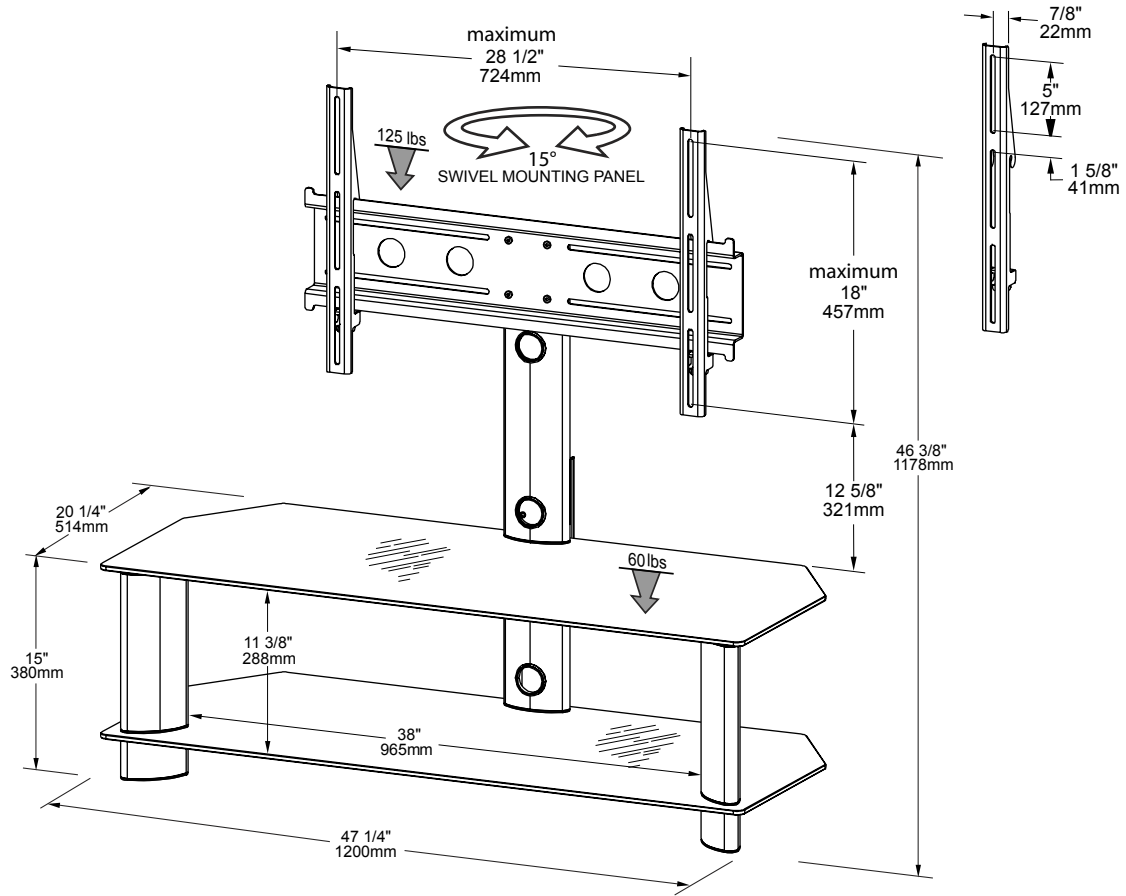

Techcraft Manufacturing Inc.

Copyright © Techcraft 2006. All rights reserved. No part of this drawing may be reproduced in any form by any photographic, electronic, mechanical or other means, or used in any information storage and retrieval system, without the written permission of Techcraft.

Hot Line : **1-888-476-8896**

Fax: (450) 622-3452

Email: sales@techcraft.net

Email: services@techcraft.net