



GENERAL PRODUCT INFORMATION:



This product can mount to either a 4" square electrical box with round plaster ring or an octagon electrical box.

This product is suitable for indoor dry locations only.

This product can be dimmed with a standard incandescent dimmer.



CAUTION - RISK OF FIRE
This product requires installation by a qualified electrician. Before installing be sure to read all instructions and **TURN THE POWER TO THE ELECTRICAL BOX OFF.**

Install the Glass Shade & Crossbar

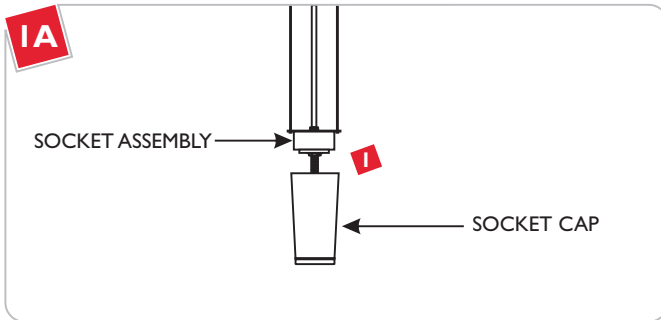

1 Unscrew and remove the socket cap from the socket assembly.

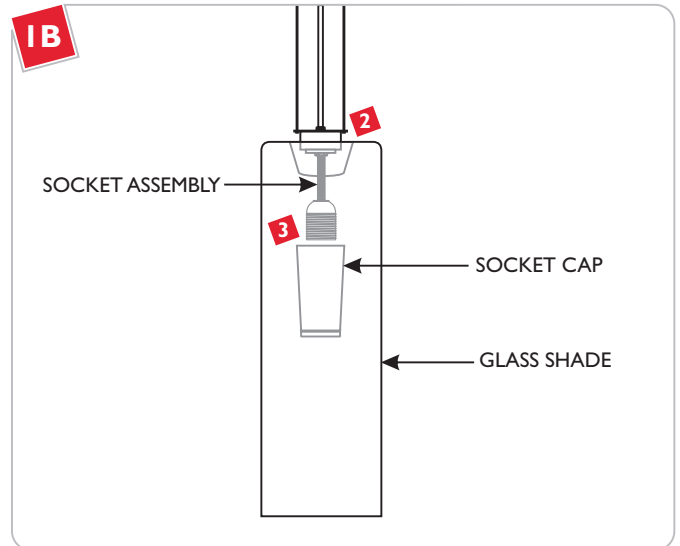

2 From top of the glass place the socket assembly into the glass shade.

3 From bottom of the glass shade place and screw the socket cap completely onto the socket assembly.

Shorten the Fixture (Optional)

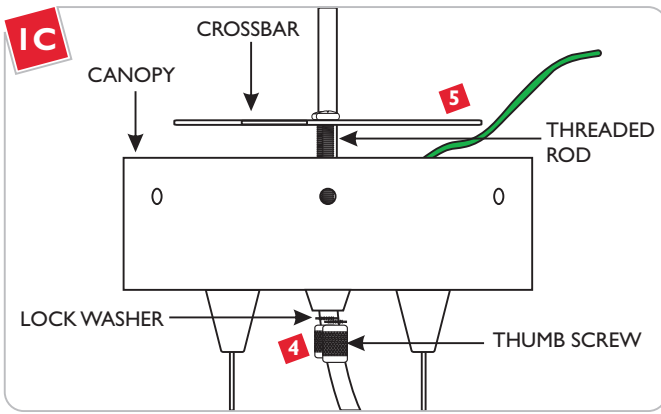

- 4 Unscrew and remove the two thumb screws and lock washers from the threaded rods.
- 5 Remove the crossbar from the canopy.

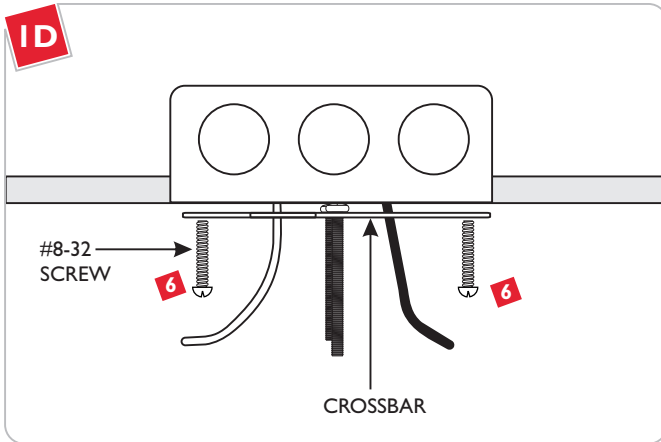

- 6 Install the crossbar to the electrical box with the two provided #8-32 screws.

NOTE: If not adjusting or shortening the fixture height, follow "Install the Fixture" and "Install the Lamp" steps on page 4.

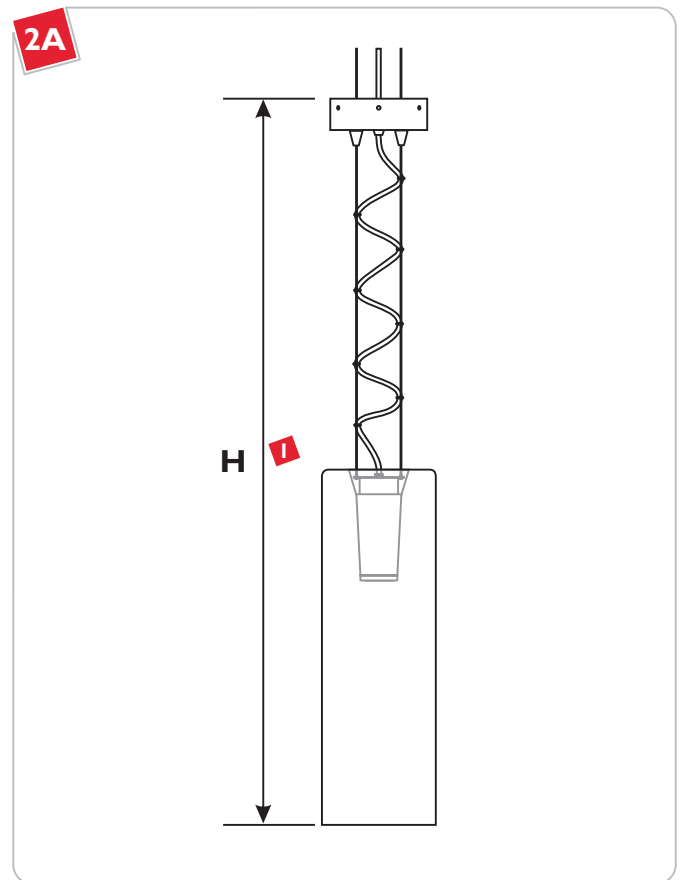

- 1 The overall fixture height (H) is measured from bottom of the glass shade to top of the canopy.

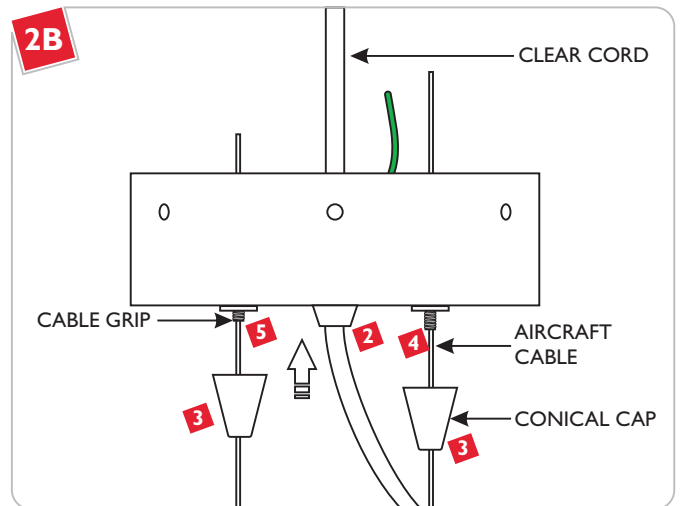

- 2 Slide the clear cord up into the canopy.
- 3 Unscrew the conical caps and slide them down the aircraft cables.
- 4 Slide the aircraft cables through the cable grips into the canopy.
- 5 To pull the aircraft cable, unlock it by pushing the cable grip in.

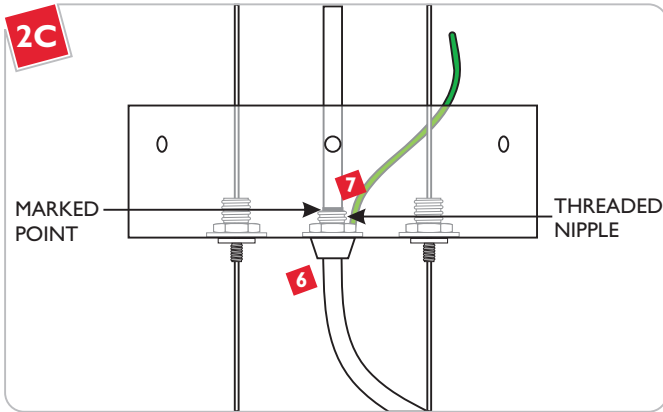

- 6 Adjust the fixture height by moving the clear cord and aircraft cables up or down.
- 7 When the desired height is achieved, from inside mark the clear cord right behind the threaded nipple for the strain relief location.

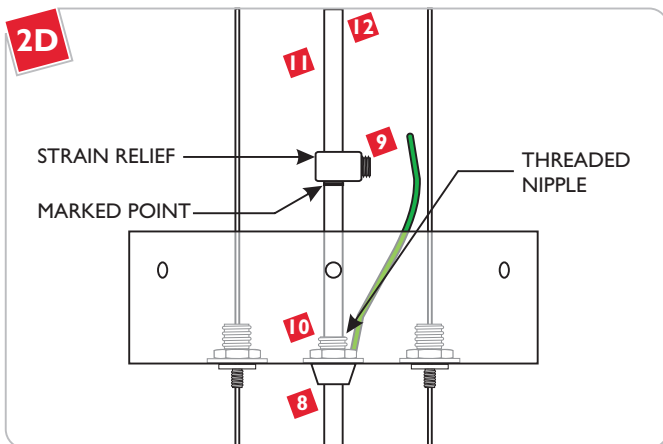

- 8 Feed the clear cord into the canopy so that the marked point is exposed behind the canopy.
- 9 Loosen the strain relief screw (**Do Not Remove**). Slide the strain relief down the clear cord right above the marked point and tighten the screw.
- 10 Slide the clear cord down so that the strain relief seats against the threaded nipple.
- 11 For power connection, leave at least 6" of the clear cord exposed behind the canopy.
- 12 Cut off the excess clear cord with a sharp cutter.

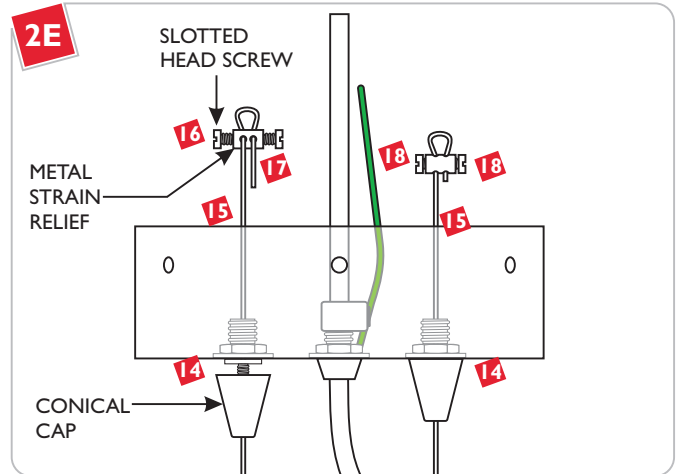

- 13 To adjust the aircraft cables following steps 3 through 5 on page 1.
- 14 Slide the conical caps up and screw them completely to the cable grips.
- 15 Leave 6" of the aircraft cable exposed behind the canopy. Trim off excess aircraft cable.
- 16 Back out (**Do Not Remove**) the slotted head screws on the metal strain reliefs and remove the cut out aircraft cables.
- 17 For each aircraft cable exposed behind the canopy, feed the aircraft cable from one strain relief hole, then loop it and feed it through the other hole.
- 18 Tighten the slotted head screws.

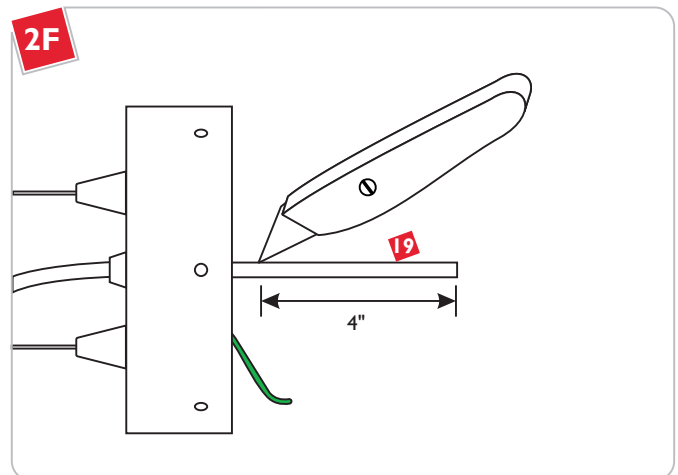

- 19 From the end of the clear cord, strip the outer insulation 4" using a sharp knife. **Make sure not to nick the inner wires.**
- 20 Strip 1/4" of insulation from the inner insulated wires. The bare inner wire is the ground wire.

Install the Fixture

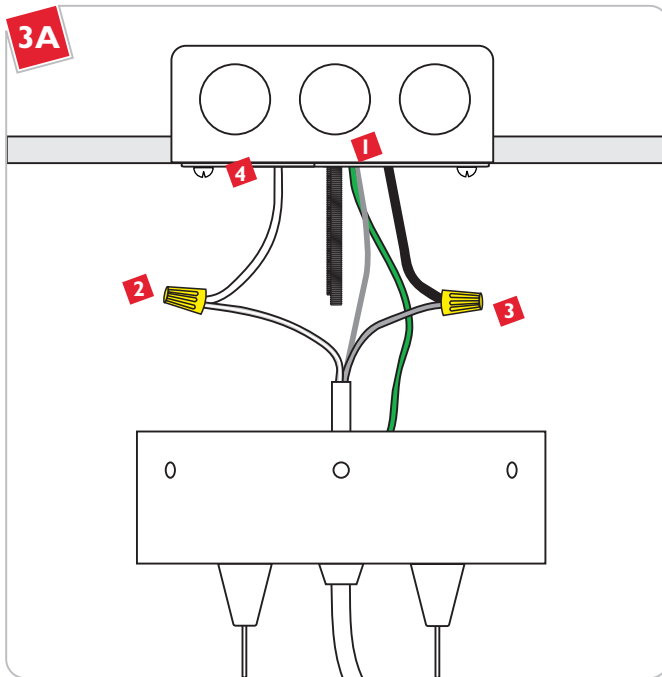

- 1** Connect the fixture bare wire and the canopy ground wire to the ground in accordance with local electrical codes.
- 2** Connect the fixture wire with the white strip to the neutral power line wire with a wire nut.
- 3** Connect the last fixture wire to the hot power line wire with a wire nut.
- 4** Place all wires and wire nut connections properly inside the electrical box.

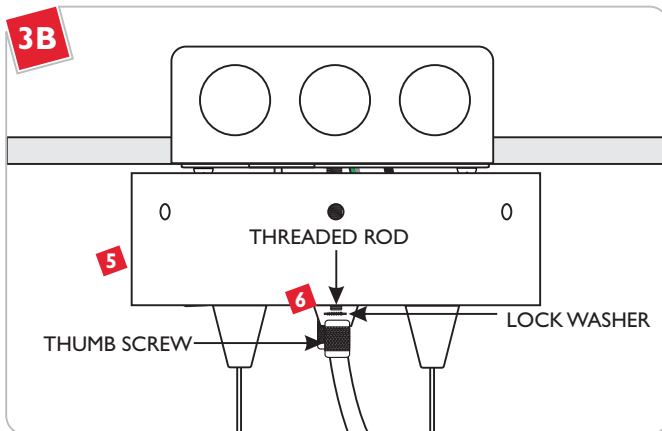

- 5** Align the canopy holes with the crossbar threaded rods and push it completely up.
- 6** Replace and tighten the lock washer and thumb screws to the threaded rods to secure the fixture in place.

Install the Lamp

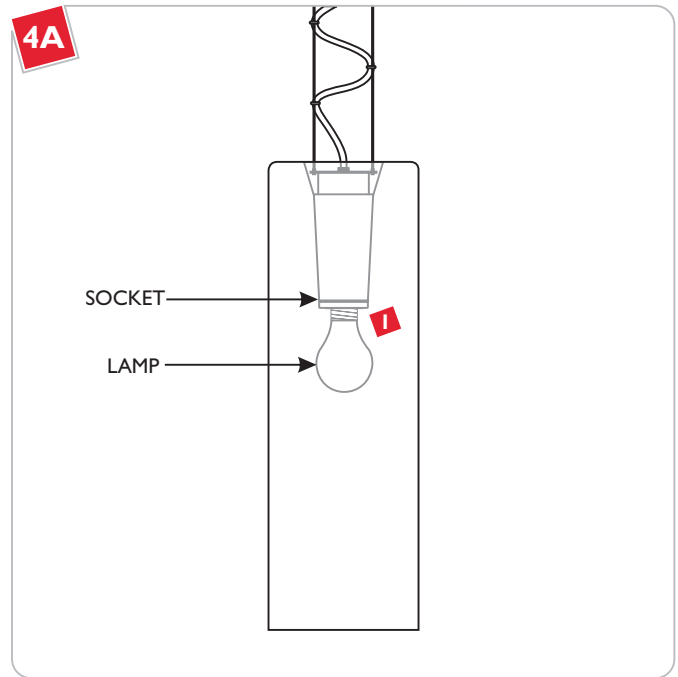

CAUTION: To reduce the risk of a burn or electric shock during relamping, disconnect the power to the fixture.

Use **MAX** 120 Volt, **100** Watt Type A19 Medium Base Lamp.



- 1** Screw the lamp completely into the socket.

SAVE THESE INSTRUCTIONS!

LBL Lighting

7400 Linder Ave, Skokie, IL 60077
800.323.3226 - 847.626.6300

www.lblighting.com

© 2008 LBL Lighting. All rights reserved. The "LBL Lighting" graphic is a registered trademark of LBL Lighting. LBL Lighting reserves the right to change specifications for product improvements without notification.

A Generation Brands Company