

CATALOG NUMBER	TYPE
PROJECT	

BULLET QUICK CONNECT™ pendant G966CH

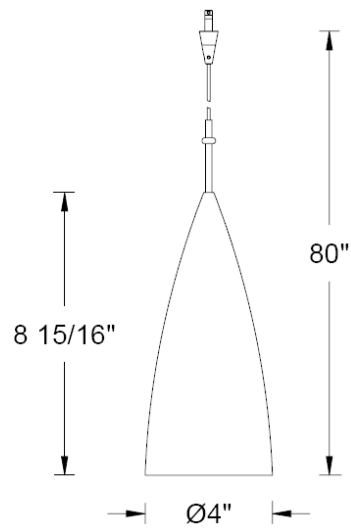

Ordering Matrix		
Model	Shade	Socket Set Finish
QP MP-	966CH	BN – Brushed Nickel CH – Chrome DB – Dark Bronze

Example (Model-Glass/Socket Set Finish) : QP966CH/CH

Product Details	Specification Features
<p>Description: Bullet shape metal shade Outer surface: Chrome Inner surface: High reflectance white powder coat.</p> <p>Materials: QP966 QUICK CONNECT™ pendant includes (1) G966 Metal shade (1) QP-902 Pendant socket set (1) BP-50 Xenon Bi-pin lamp</p> <p>MP-966 Mono-point pendant includes: (1) G966 Metal shade (1) 902 Pendant socket set (1) MP-60E Mono-point canopy (1) BP-50 Xenon Bi-pin lamp</p> <p>Socket: Include 6' of braided cable and hang-straight tube.</p> <p>Wattage: 12v 50w max.</p> <p>Listing: UL & CUL Listed.</p>	<ul style="list-style-type: none"> The QUICK CONNECT™ pendant requires a QUICK CONNECT™ adapter to use with WAC's low voltage rail and track systems (DUORAIL™, SOLORAIL™ and Linear track), line voltage track systems, (FLEXRAIL1™, FLEXRAIL2™ and 120v track) and mono-point and multipoint canopies. 5 year product warranty.