

| | |
|-----------------------|-------------|
| CATALOG NUMBER | TYPE |
| PROJECT | |

BULLET QUICK CONNECT™ pendant G966BN

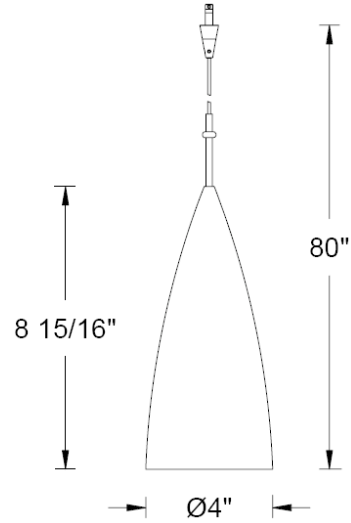

| Ordering Matrix | | |
|-------------------|--------------|---|
| Model | Shade | Socket Set Finish |
| [] | [] | [] |
| QP MP- | 966BN | BN – Brushed Nickel CH – Chrome DB – Dark Bronze |

Example (Model-Glass/Socket Set Finish) : QP966BN/BN

| Product Details | |
|---------------------|---|
| Description: | Bullet shape metal shade Outer surface: Brushed Nickel Inner surface: High reflectance white powder coat. |
| Materials: | QP966 QUICK CONNECT™ pendant includes (1) G966 Metal shade (1) QP-902 Pendant socket set (1) BP-50 Xenon Bi-pin lamp MP-966 Mono-point pendant includes: (1) G966 Metal shade (1) 902 Pendant socket set (1) MP-60E Mono-point canopy (1) BP-50 Xenon Bi-pin lamp |
| Socket: | Include 6' of braided cable and hang-straight tube. |
| Wattage: | 12v 50w max. |
| Listing: | UL & CUL Listed. |

| Specification Features |
|--|
| <ul style="list-style-type: none"> The QUICK CONNECT™ pendant requires a QUICK CONNECT™ adapter to use with WAC's low voltage rail and track systems (DUORAIL™, SOLORAIL™ and Linear track), line voltage track systems, (FLEXRAIL1™, FLEXRAIL2™ and 120v track) and mono-point and multipoint canopies. 5 year product warranty. |

WAC Lighting reserves the right to modify the design of our products as part of the company's continuous improvement program.