

CATALOG NUMBER	TYPE
PROJECT	

QUICK CONNECT SOCKET SET **MODEL QP-501**

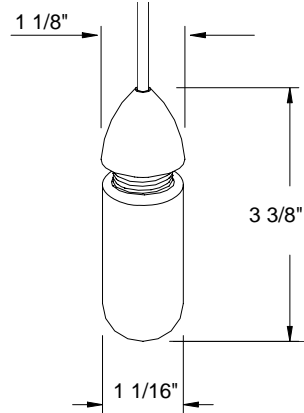

Shown with G518 Shade



Ordering Matrix		
Model	Part Number	Finish
QP	501	BZ CH PT

Ordering Example (model number – part number – finish): QP-501-CH

Product Details	
Description:	Quick connect pendant socket set for use with select G500 series glass shades. Socket set is low voltage and can be used with 12 volt or 24 volt systems.
Compatible Systems:	Socket set is compatible with these W.A.C. systems; Monorail, Flexrail, Track, Linear, Monopoint and Multipoint canopies. Monorail requires one LM-QADP for each QP-501 used. Flexrail requires one HM-EN50 for each QP-501 used. Linear requires one SADP for each QP-501 used. Track systems require one EN-XQ50AR for each QP-501 used. Monopoint and Multipoints do not require additional parts.
Lamp:	Uses 50w Halogen JC-50-CL lamp (one 12V lamp included).
Materials:	Machined brass parts and six feet of a low voltage braided wire. Frosted glass bulb shield with threaded collar.
Mounting:	Depending on the system being used, the socket set quick connect jack is inserted into a quick connect adaptor located on the track, canopy, or transformer.
Finish:	Available in Bronze (BZ), Chrome (CH), and Platinum (PT).
Listing:	UL & CUL Listed.

Specification Features
<ul style="list-style-type: none"> • Socket set comes with 6 feet of cable and may be field cut to any length. • “Quick-Ship” item, always in stock and available for immediate shipment. • Current compatible glass shade selection numbers thirty four, with more offerings being added every year. The most recent additions can be found on the website, www.waclighting.com. • 2 year W.A.C. Lighting product warranty.