

# INSTRUCTIONS: Low Voltage Mono Rail Kit

## Models: LM-SK-150E & LM-SK-250E

### Caution:

Read all instructions.

Turn off power at main switch before installing or modifying the system.

Do not install the system:

- Within six inches of any curtain or combustible materials
- Less than 5 feet above a floor
- In a damp or wet location
- Concealed, or extended through building walls.

After first 1/2 hour of operation, switch off and check all connections for excessive heat.

Loose connections must be tightened to prevent overheating which can damage the system and pose a potential fire hazard. Do not over tighten.

Intended for installation by a qualified electrician.

Installation should be in accordance with NEC and local codes. Use minimum AWG #10 wire for secondary wiring.

### Overview:

Power to low volt mono rail is supplied by a 12 volt 150 watt electronic transformer (model LM-SK-150E), or by a 250 watt transformer ( model LM-SK-250E). The transformer is generally compatible for use with standard incandescent dimmers.

Choices of Mono rail fixtures include rail mounted heads, quick connect fixtures, and quick connect pendants.

This kit contains the components for mounting to a flat surface such as a dry wall ceiling or wall. Accessories may be purchased for drop ceiling, or sloped ceiling applications.

Mono rail is composed of two copper conductors separated by a plastic insulator. It is flexible and bendable. Rail is supplied in 4 ft lengths and may be field cut.

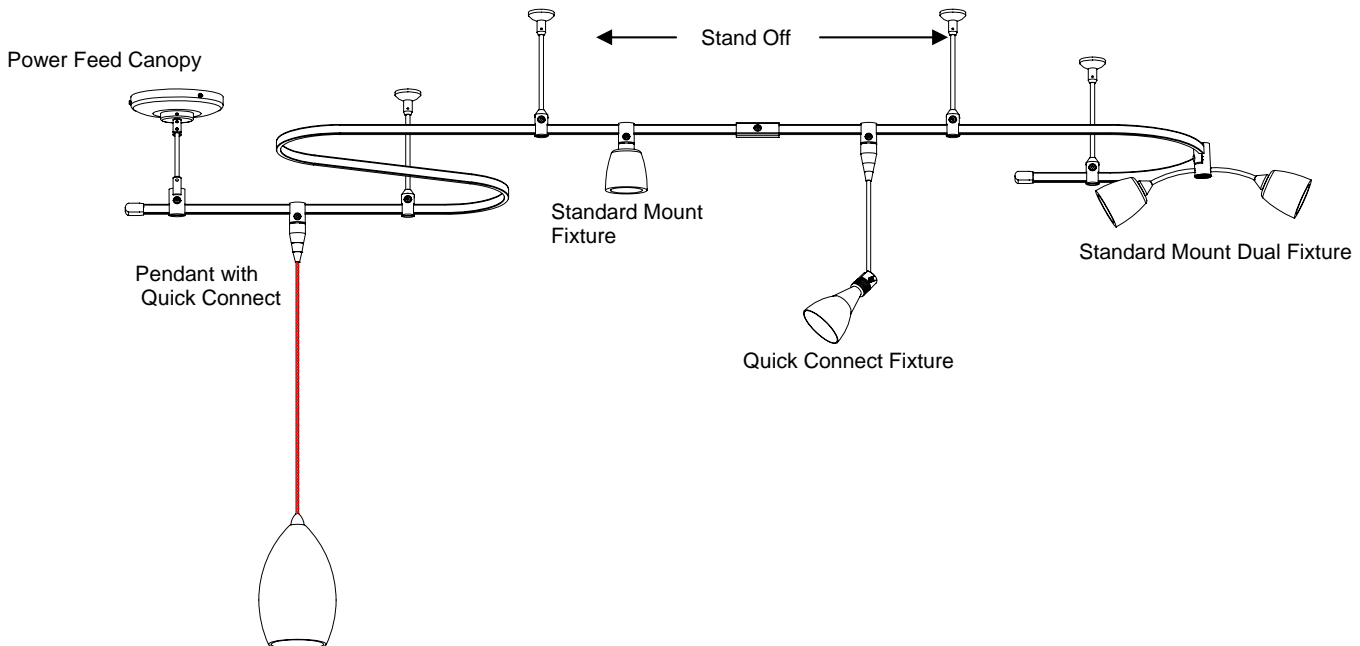

Voltage Drop Guideline				Run length
LM-EN12-150E	12V	150W	Electronic	30
LM-EN12-250E	12V	250W	Electronic	12
Surface mount data based on full load to end of rail.				

### Installing Transformer:

1. The junction box will support the entire weight of the transformer, make sure it is adequately braced and supported. Extension wires are supplied to connect junction box wires to the transformer input wires. Connect white neutral wire to white wire, and black hot wire to black wire with wire nuts. The ground wire may be green or bare copper, connect it to the green extension wire
2. Pass the open ends of the wires through the center hole of the cross bar/ threaded tube assembly, and mount cross bar to junction box as shown
3. Open the transformer case by removing the three screws on the perimeter. The cover halves will separate but not detach, allow the lower half to hang temporarily
4. Raise the support plate & transformer assembly on to the threaded tube. Attach the heavy nut to the bottom of the tube and tighten so the transformer assembly is close to the ceiling
5. Connect the extension wires to the transformer input wires, with wire nuts. Follow the previous color code.
6. Position the bottom cover so the power feed adapter is aligned to receive monorail. Close the bottom cover and secure with the three screws removed earlier.
7. Loosen the screw on the rail adapter so that the two pieces will slip over the rail.
8. Hold the two adapter halves against the rail while tightening the screw. It is important that the adapters halves seat firmly against the rail.
9. After the first 20 minutes of operation switch off system and check for abnormal heat. Hot spots are caused by poor connection, correct by re-tightening.

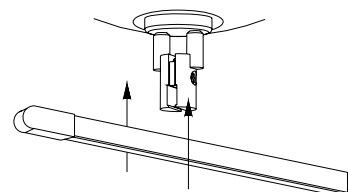
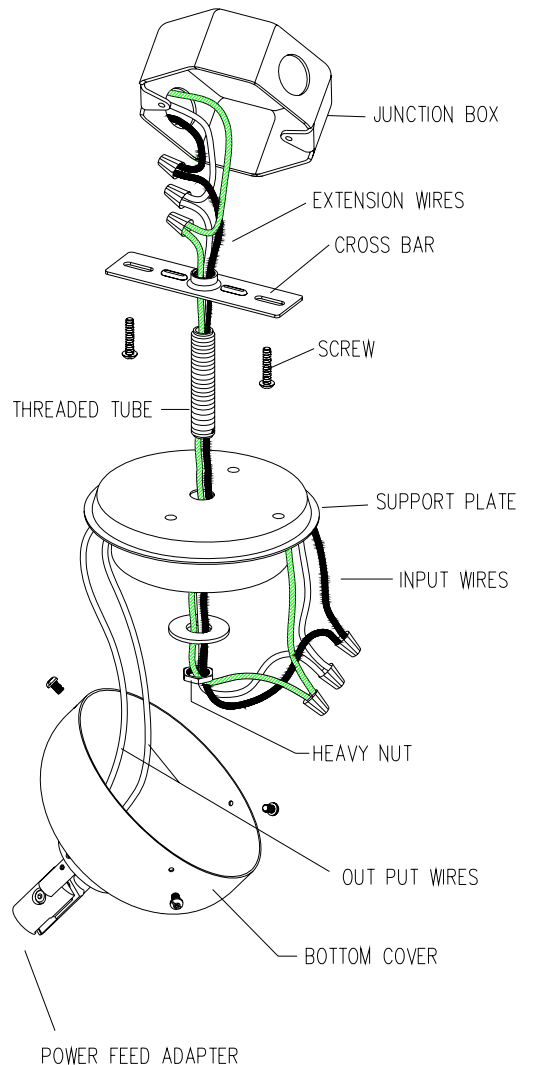

**Note:** These models are equipped with electronic transformers. An electronic low voltage dimmer is recommended.

High frequency output cannot be read by most standard multi meters.

The transformers require a minimum load to work properly. 250-watt model has a 100-watt minimum.

100 & 150-watt models have a 60-watt minimum.

**Important: If system does not light on first power up, turn off power and check for shorts with a continuity tester. Leaving power on will harm the transformer.**

## Monorail mounting:

Rail can be installed on a flat surface, a sloped ceiling, or a suspended ceiling.

1. Use two standoffs for 4ft rail, and three for an 8ft section. Use additional standoffs to support tightly curved sections.
2. If bending rail, do this at floor level, then raise to ceiling and mark the location of standoff supports.
3. If rail cannot be raised, use a plumb line to mark location of stand offs on the ceiling.
4. For dry wall, drill holes and insert ceiling anchors (supplied) through standoff bases and then to ceiling (shown). Tighten until snug.

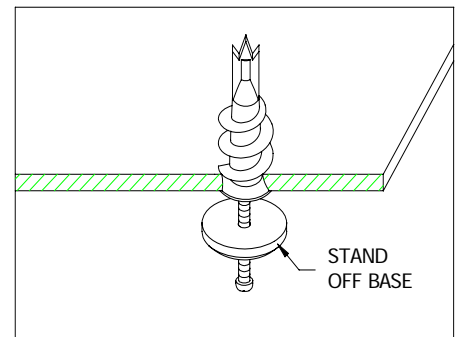
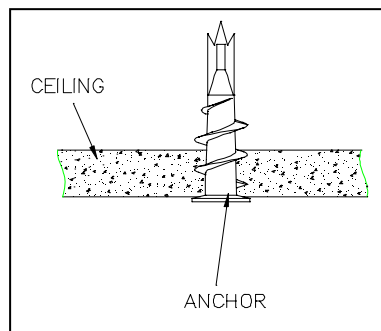
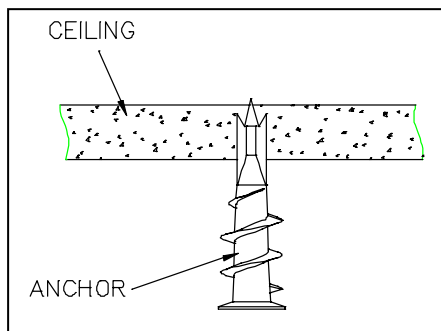

5. For wood surfaces insert wood screws through standoff bases and fully tighten.
6. Install standoff posts with rail adapters. Twist clock wise to tighten.
7. To obtain proper alignment with mono rail loosen the set screw near the top of the standoff, (using a 1/16" allen wrench) adjust then re- tighten.
8. Loosen the set screw in the rail adapter, so that there is sufficient clearance to slip the rail between the two halves.
9. Raise the rail to ceiling level and support it.
10. Starting from the center of rail, slip track between the two halves of the rail adapter. Using a 5/32" Allen wrench (supplied), tighten the set screw (clockwise) until the rail adapter seats firmly against both sides of the rail.
11. Repeat procedure for remaining standoffs.

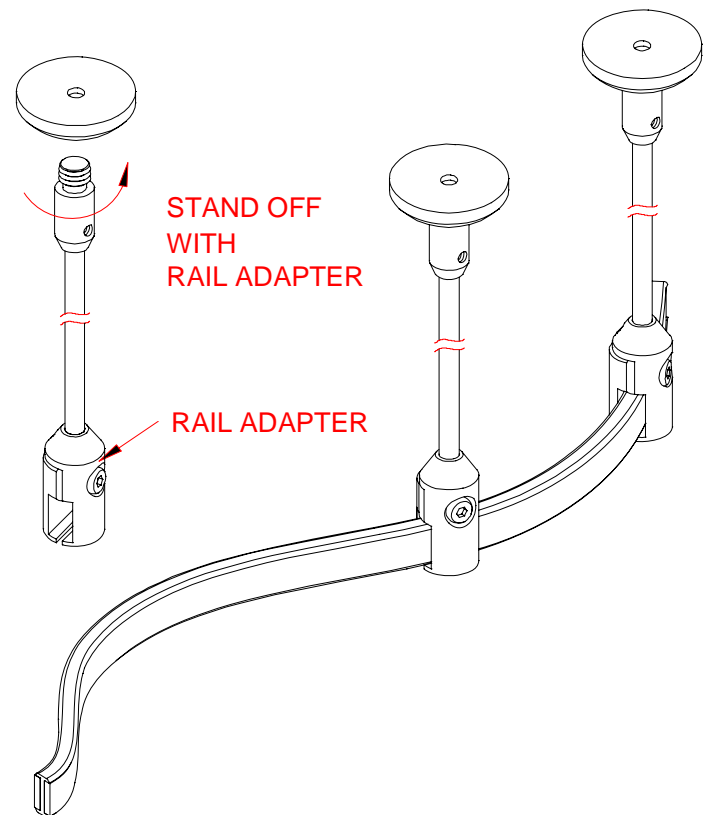

**Field Cutting a Standoff:**

1. Remove the small setscrew located on the upper fitting and pull the rod free (use a 1/16" allen wrench).
2. Use a tube cutter for the cleanest cut. If using a hacksaw be sure to brush away any metal filings.
3. Cut to size and refit.
4. The procedure for standoffs on the power feed canopy is the same.

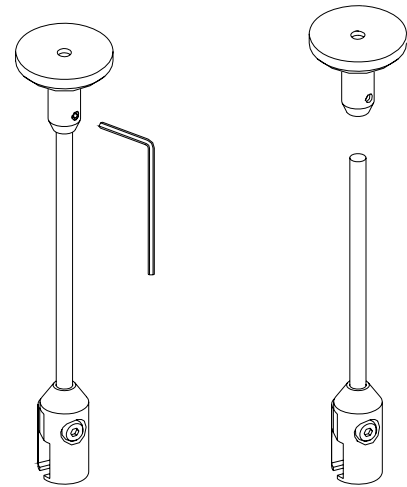

**T-Bar Ceilings:**

Note: Rail stand offs are required to be mounted to structural members. Do not mount only to acoustical panels.

1. Follow steps 1 through 3 for rail mounting above.
2. Place T-bar clip standoff against the ceiling T-bar, and turn clockwise to engage.
3. Proceed from step 5 above.

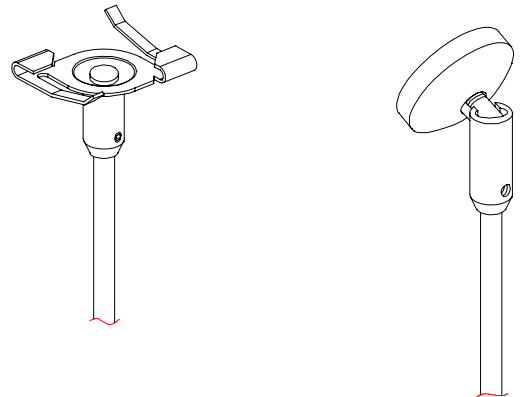

T BAR

SLOPED CEILING

**Bending Mono Rail:**

1. Rail is best formed, by bending over a round object.
2. Start with a broader radius and form over progressively smaller diameters.
3. We recommend a minimum radius of 15".
4. Broad curves can be accomplished by gradual hand bending.
5. Once formed, the ends of the rail will be unequal. If connecting with another connector, snip the rail end to make even, other wise just apply an end cap.
6. Pre-stress track to shape while at floor level. Do not stress between ceiling standoffs to form shapes.

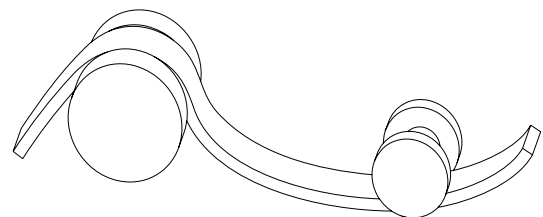

**Field Cutting Rail:**

1. Rail may cut to length in field.
2. Use fine-toothed hacksaw or heavy-duty bolt cutter.
3. Thoroughly clear away all cutting debris.
4. Inspect end to insure the insulator has not been damaged and there are no sharp edges.
5. Re-install track end cap.

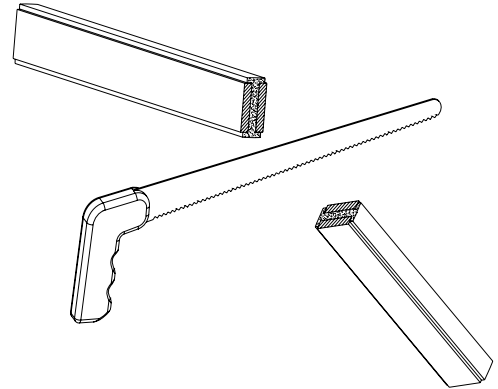

**Installing Fixtures:**

**Note:** Fixtures attach to the rail with a two-piece adapter. It is important that the setscrews of the adapter all face the same way. This reduces the possibility of an electrical short.

1. Using a 5/32" Allen wrench (supplied), loosen the setscrew enough to allow adapter halves to slip over mono rail.
2. Seat the adapter notches to the rail and tighten the setscrew.
3. Inspect the rail to see that the adapters are firm against it.
4. If the adapter is the quick connect type, thread the quick connect adapter by screwing clockwise until snug.

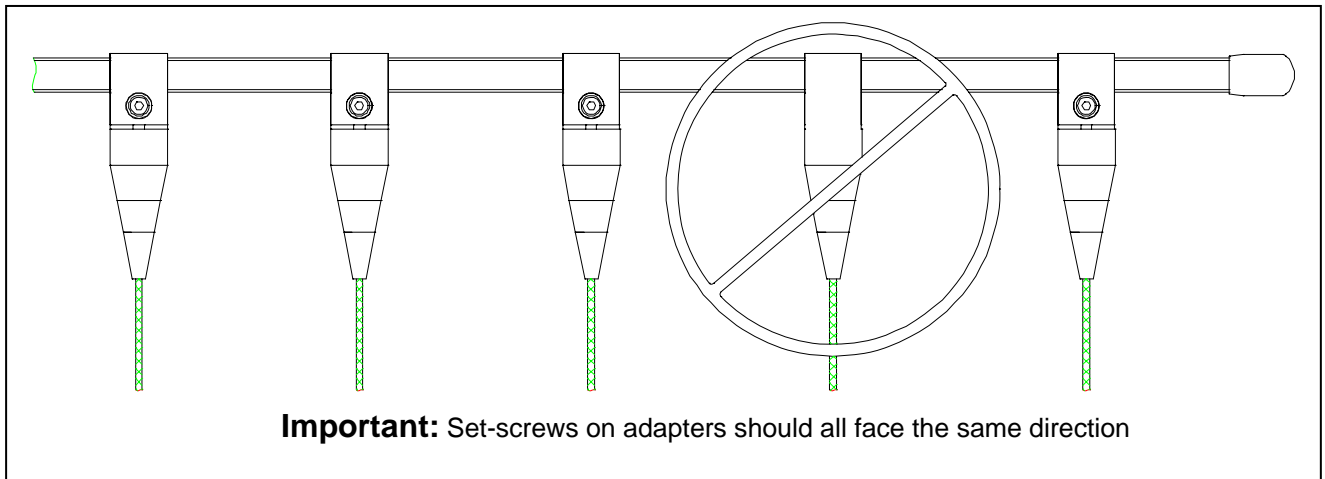
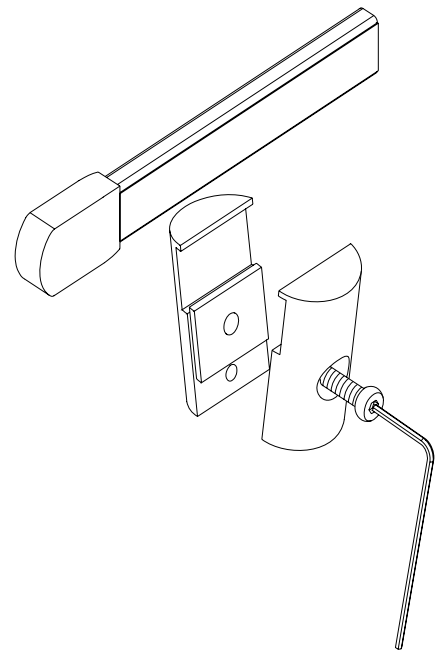

**Important:** observe polarity, install rail adapters with screws facing the same side of the rail.

**Parts list:**

<b>LM-SK-150E</b>		
<b>Quantity</b>	<b>Model</b>	<b>Description</b>
1	LM-EN12-150E	Surface mount 12V electronic transformer, 150 watt
2	LM-T4	Mono rail section 4' long
1	LM-I	"I" connector, for joining two rail sections
2	LM-EC	End cap
3	LM-X4	Stand off ( suspension ) rod 4 ½" long.
<b>LM-SK-250E</b>		
1	LM-EN12-250E	Surface mount 12V electronic transformer, 250 watt
3	LM-T4	Mono rail section 4' long
2	LM-I	"I" connector, for joining two rail sections
2	LM-EC	End cap
5	LM-X4	Stand off ( suspension ) rod 4 ½" long.

Retain instructions for future reference.



**W·A·C** | LIGHTING  
www.waclighting.com

615 South Street, Garden City, NY 11530  
Tel: (516) 515-5000 Fax: (516) 516-5050

168 Brea Canyon Road, City of Industry, CA 91789  
Tel: (909) 468-1848 Fax: (909) 468-9958