

CATALOG NUMBER	TYPE
PROJECT	

SOLORAIL™ – SURFACE MOUNT TRANSFORMER

MODEL LM-EN12-300M

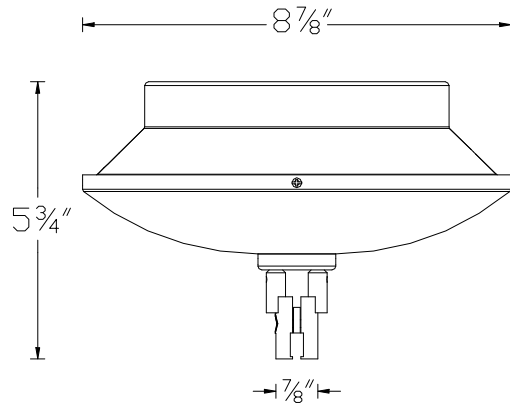

Ordering Matrix		
Model	Part Number	Finish
[]	[]	[]
LM-EN12	300M	DB CH BN

Ordering Example (model number – part number – finish): LM-EN12-300M-CH

Product Details	
Description:	Surface mount magnetic low voltage transformer for the WAC Solorail™ system. The canopy style enclosure includes the transformer and the track power feed adaptor.
Catalog Number:	LM = Low voltage Solorail™ EN12 = 12 volt, enclosed canopy transformer 300M = 300 watt magnetic
Input:	120V (50/60Hz)
Output:	12V
Max Load:	300W
Max Input Amp:	2.5A (@ 120V)
Mounting:	Installs to a standard junction box. Total weight = 11 lbs. The standard LM-EN12-300M configuration matches the height of the 5 3/4" standoffs (LM-X5).
Finish:	Available in Dark Bronze (DB), Chrome (CH), and Brushed Nickel (BN).
Listing:	UL & CUL Listed.

Specification Features
<ul style="list-style-type: none"> • Dims with magnetic low voltage dimmers. • Output circuit breaker located on the upper lip of the canopy enclosure is a magnetic push to reset type. • Contains integral de-buzzing coil. • The surface mount canopy transformer is an ideal choice when the installation is on an existing ceiling. • 5 year WAC Lighting product warranty.

CATALOG NUMBER	TYPE
PROJECT	

SOLORAIL™ – SURFACE MOUNT TRANSFORMER

MODEL LM-EN24-300M

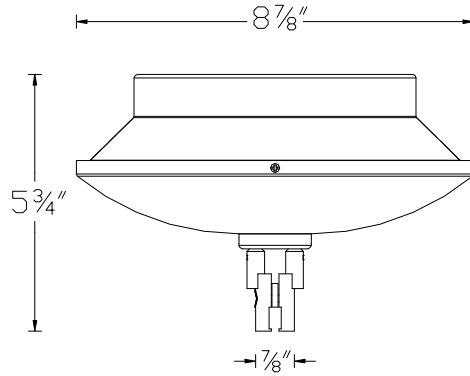

Ordering Matrix

Model	Part Number	Finish
[]	[]	[]
LM-EN24	300M	DB CH BN

Ordering Example (model number – part number – finish): LM-EN24-300M-DB

Product Details

Description:	Surface mount magnetic low voltage transformer for the WAC Solorail™ system. The canopy style enclosure includes the transformer and the track power feed adaptor.
Catalog Number:	LM = Low voltage Solorail™ EN24 = 24 volt, enclosed canopy transformer 300M = 300 watt magnetic
Input:	120V (50/60Hz)
Output:	24V
Max Load:	300W
Max Input Amp:	2.5A (@ 120V)
Mounting:	Installs to a standard junction box. Total weight = 11 lbs. The standard LM-EN12-300M configuration matches the height of the 5 3/4" standoffs (LM-X5).
Finish:	Available in Dark Bronze (DB), Chrome (CH), and Brushed Nickel (BN).
Listing:	UL & CUL Listed.

Specification Features

- Dims with magnetic low voltage dimmers.
- Output circuit breaker located on the upper lip of the canopy enclosure is a magnetic push to reset type.
- Contains integral de-buzzing coil.
- The surface mount canopy transformer is an ideal choice when the installation is on an existing ceiling.
- 5 year WAC Lighting product warranty.