

<b>CATALOG NUMBER</b>	<b>TYPE</b>
<b>PROJECT</b>	

**DUORAIL™ – SURFACE MOUNT TRANSFORMER** **MODEL LM2-EN12-500M**

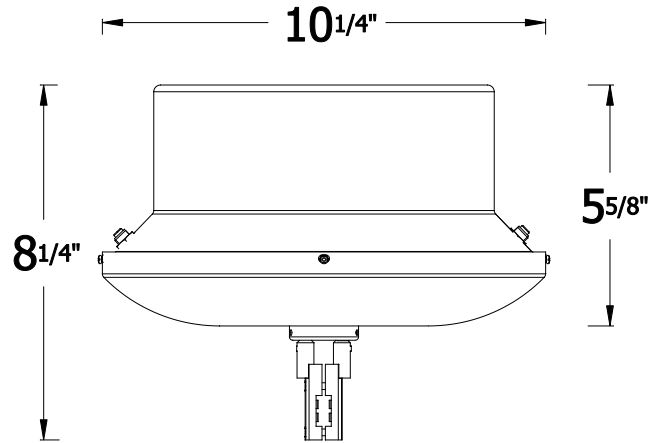

Ordering Matrix		
Model	Part Number	Finish
LM2-EN12	500M	DB CH BN

Ordering Example (model number – part number – finish): LM2-EN12-500M-BN

Product Details	
<b>Description:</b>	Surface mount magnetic low voltage transformer for the WAC Duorail™ system. The canopy style enclosure includes the transformer and the track power feed adaptors.
<b>Catalog Number:</b>	LM2 = Low voltage Duorail™ EN12 = 12 volt, enclosed canopy transformer 500M = 500 watt magnetic
<b>Input:</b>	120V (60Hz)
<b>Output:</b>	12V
<b>Max Load:</b>	500W (2 x 250W circuits)
<b>Max Input Amp:</b>	2X2.5A (@ 120V)
<b>Mounting:</b>	Installs to a standard junction box. Total weight = 25 lbs. The standard LM2-EN12 configuration matches the height of the 8 1/16" standoffs (LM2-X8).
<b>Finish:</b>	Available in Dark Bronze (DB), Chrome (CH), and Brushed Nickel (BN).
<b>Listing:</b>	UL & CUL Listed. 5 year WAC Lighting product warranty.

Specification Features
<ul style="list-style-type: none"> <li>The LM2-EN12-500M model has two 250w feeds .</li> <li>Dims with magnetic low voltage dimmers.</li> <li>The output circuit breakers located on the upper lip of the canopy enclosure are a magnetic push to reset type.</li> <li>Contains integral de-buzzing coil.</li> <li>The surface mount canopy transformer is an ideal choice when the installation is on an existing ceiling.</li> </ul>