

INSTALLATION INSTRUCTIONS: 4" Airtight IC New Construction Housing

Model: R-402S-N-ICA

Important:

Read all instructions before installing.

For installation by a qualified electrician.

System is intended for installation in accordance with National Electric Code, and local regulations. Consult with local inspector to assure compliance.

To reduce the risk of fire, electrical shock and injuries to persons, turn off power at main switch before installing or modifying the system. Retain instructions for future maintenance reference.

Overview:

New construction housing suitable for direct insulation contact. Airtight rated. Trims ordered separately.

Mounting:

Supplied with two hanger bars, (24" max). Bars can be used on all four sides and are notched on the ends to fit over "T" bars in suspended ceilings. Hanger bars include a captive mounting screw for ease of installation.

1. Align the bottom of the hanger bar with the bottom of the wood joist.
2. Secure the screws on each end.
3. Junction box is suitable for branch wiring and has trade size knockouts and integral Romex connectors.
4. For Romex, pry open the knock out and push the wire through the clamp plate inside.
5. Wire connections must be installed in a manner that does not interfere with the strain relief action of the clamp.

Wiring:

1. Remove spring latched junction box door and connect wires: White fixture wire to white building wire, black fixture wire to (hot) black building wire and green ground wire to bare or insulated ground wire.
2. Secure connections with wire nuts (supplied).
3. Replace junction box door.

Trims:

1. To install trim, insert fully into housing. Three flat gripping springs will retain the trim. Open aperture trims allow the lamp to be installed after the trim is installed (diagram 1).
2. For closed aperture trims the lamp is installed first.
3. For adjustable trims, the socket snaps out of the bracket in the housing, and is attached to the base of the lamp (diagrams 3 & 3A).
4. Follow lamp type and maximum wattage information listed on the label in the housing.

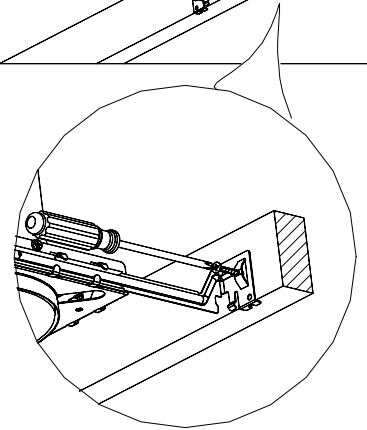
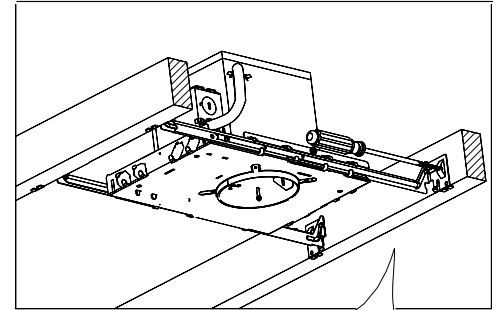

Trim types

