

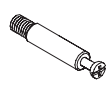







| | | | | | | | | |
|---|--|---|---|--|--|--|---|---|
|  A Cam Lock 16pcs |  B Klix Cam 16pcs |  C Dowel 14pcs |  D Adjustable Glide 6pcs |  E 6 hole L-Bracket 4pcs |  F Screw #4 x 3/8" 24pcs |  G I-Bracket 2pcs |  H Screw M6 x 20mm 12pcs |  I Cam Cover 16pcs |
|---|--|---|---|--|--|--|---|---|

STEP 1

STEP 2

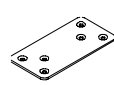

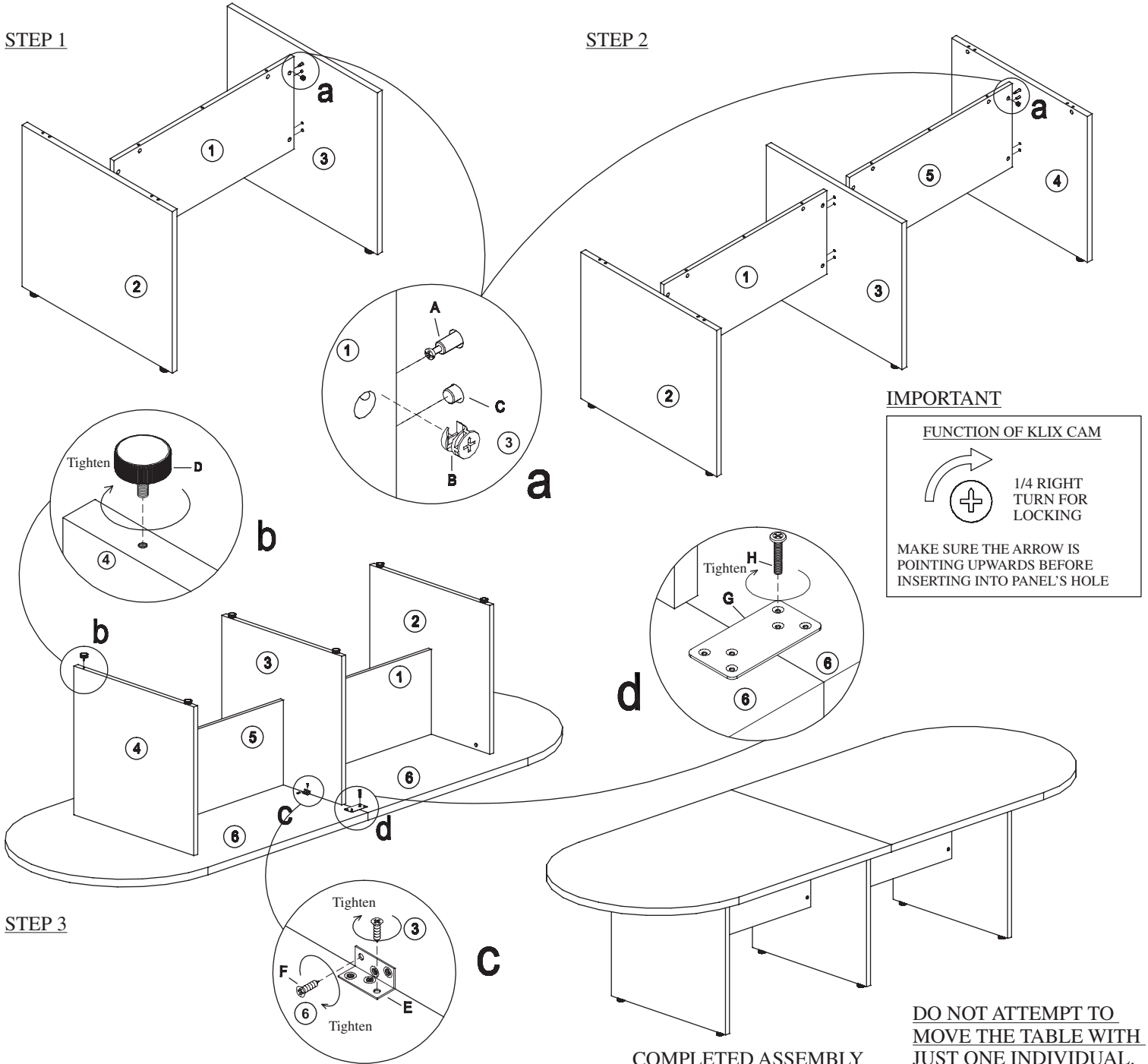
IMPORTANT

FUNCTION OF KLIX CAM



MAKE SURE THE ARROW IS
POINTING UPWARDS BEFORE
INSERTING INTO PANEL'S HOLE







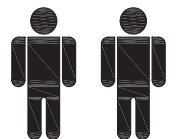

**DO NOT ATTEMPT TO
MOVE THE TABLE WITH
JUST ONE INDIVIDUAL.**

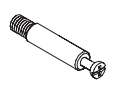
IMPORTANT NOTE:

- Place all laminated parts on a clean and smooth surface such as a rug or carpet to avoid the parts from being scratched.
- Check to be sure that you have all parts and hardware.
- Remove all wrapping materials, including staples and packing straps before you start to assemble.
- Don't tighten all screws/bolts until all completely assembled.
- Keep all hardware parts out of reach of children.
- It is recommended for 2 persons to complete this assembly.

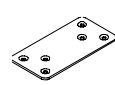

Two people are required to
assemble and move this model.

| | | | | | | | | |
|---|--|---|---|---|--|---|--|--|
| A  Verrou à came 16pcs | B  Came Klix 16pcs | C  Cheville 14pcs | D  Patin ajustable 6pcs | E  Support en L à 6 trous 4pcs | F  Vis #4 x 3/8" 24pcs | G  Support - I 2pcs | H  Vis M6 x 20mm 12pcs | I  Roue montée 16pcs |
|---|--|---|---|---|--|---|--|--|

ÉTAPE 1

ÉTAPE 2

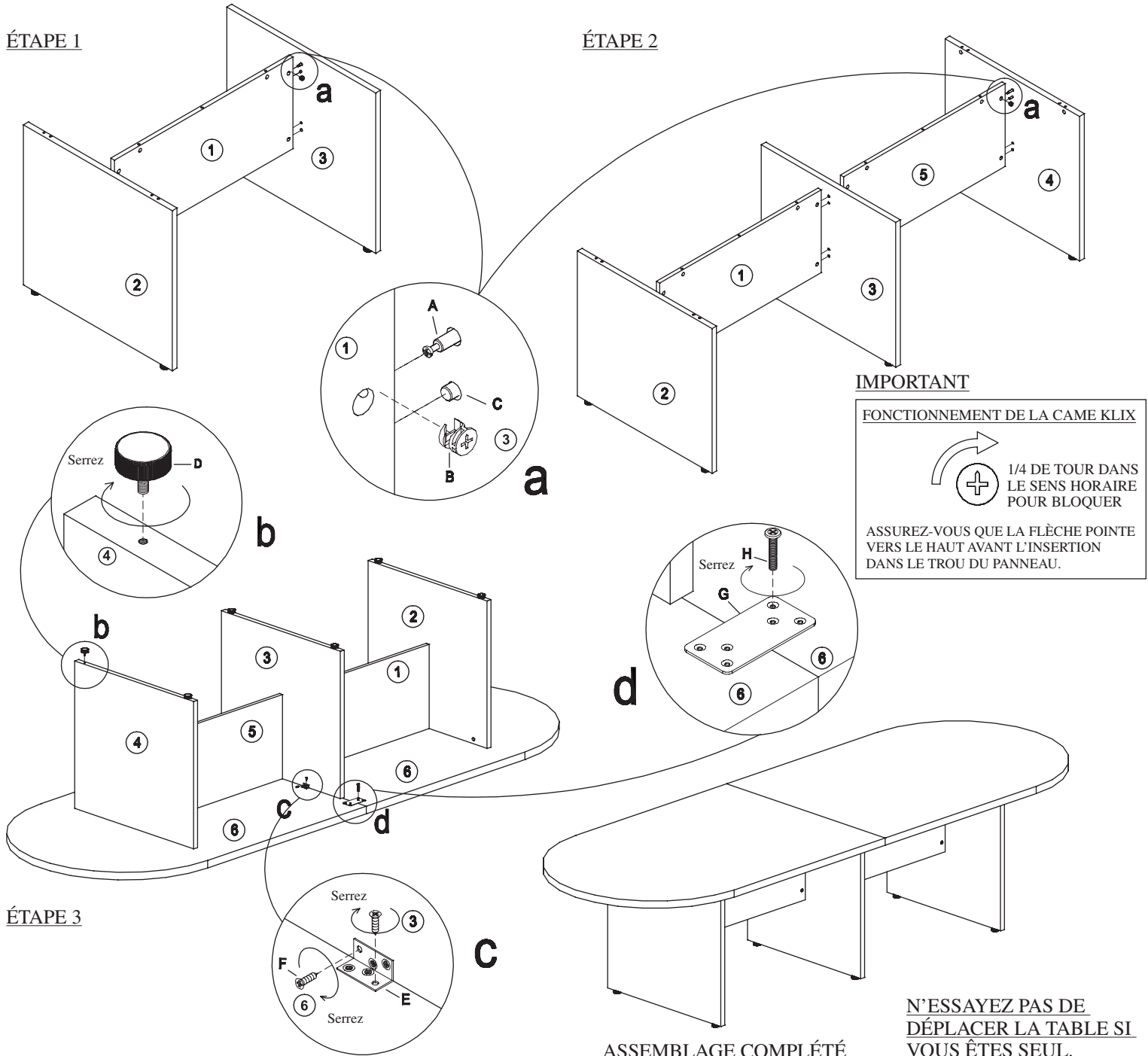

IMPORTANT

FONCTIONNEMENT DE LA CAME KLIX



1/4 DE TOUR DANS
LE SENS HORAIRE
POUR BLOQUER

ASSUREZ-VOUS QUE LA FLÈCHE POINTE
VERS LE HAUT AVANT L'INSERTION
DANS LE TROU DU PANNEAU.

ASSEMBLAGE COMPLÉTÉ

**N'ESSEYEZ PAS DE
DÉPLACER LA TABLE SI
VOUS ÊTES SEUL.**

NOTE IMPORTANT:

- Déposez toutes les pièces laminées sur une surface propre et douce comme sur une carpeite ou un tapis afin d'éviter l'éraflure des pièces.
- Vérifiez pour vous assurer que vous avez toutes les pièces et toute la quincaillerie
- Enlevez tout le matériel d'emballage, incluant les agrafes et les courroies d'empaquetage avant de débiter l'assemblage.
- Ne serrez pas aucun des boulons/vis avant d'avoir assemblé toutes les pièces
- Gardez toutes les pièces de quincaillerie hors de portée des enfants
- Il est recommandé que 2 personnes effectuent cet assemblage.

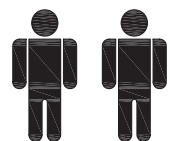

2 personnes sont requises pour l'assemblage
et le déplacement de ce modèle.

| | | | | | | | | |
|---|--|---|---|--|--|--|---|---|
| A  Seguro de ajuste 16pcs | B  Leva 16pcs | C  Taquete 14pcs | D  Riel ajustable 6pcs | E  Soporte de escuadra de 6 orificios 4pcs | F  Tornillos #4 x 3/8" 24pcs | G  Soporte I 2pcs | H  Tornillo M6 x 20 mm 12pcs | I  Rueda montada 16pcs |
|---|--|---|---|--|--|--|---|---|

PASO 1

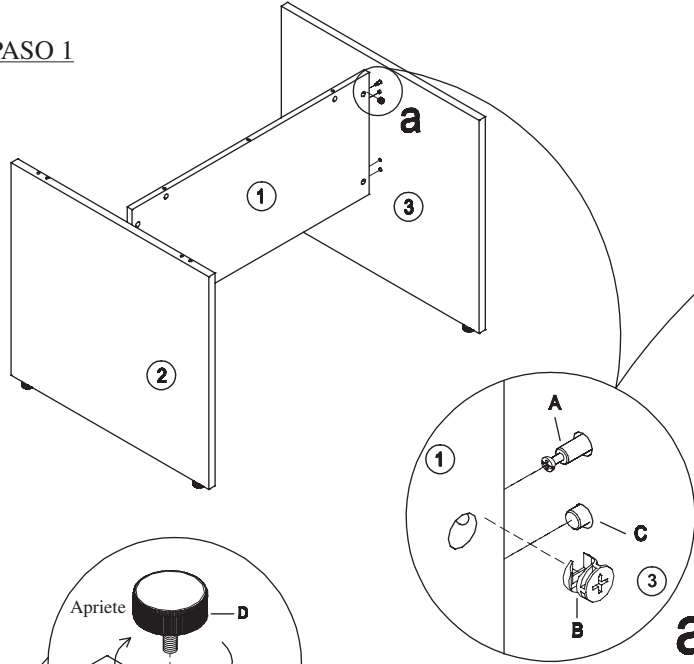

PASO 2

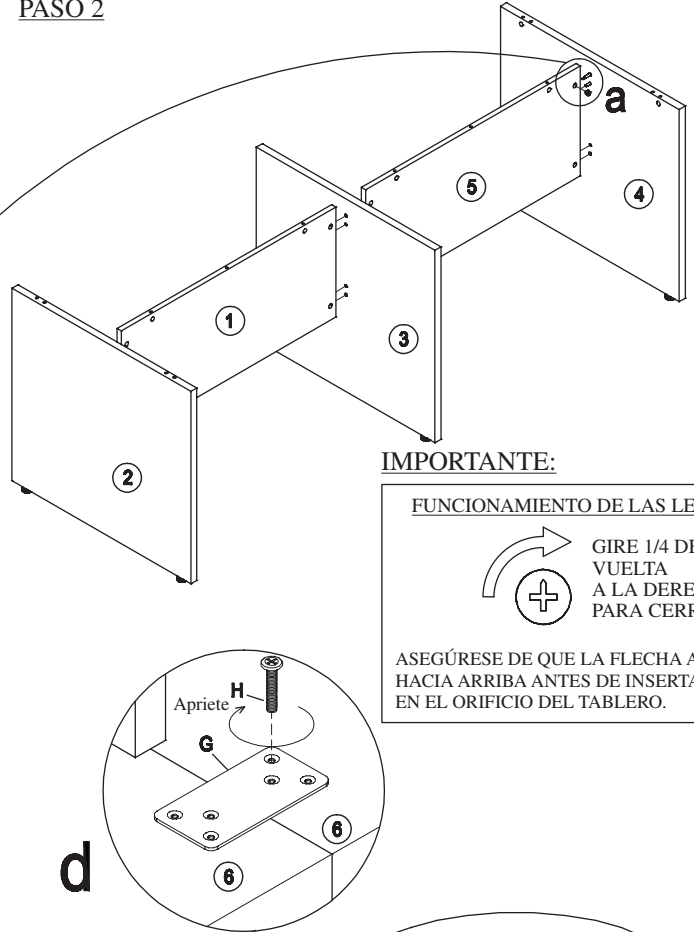

IMPORTANTE:

FUNCIONAMIENTO DE LAS LEVAS



GIRE 1/4 DE VUELTA A LA DERECHA PARA CERRAR.

ASEGÚRESE DE QUE LA FLECHA APUNTA HACIA ARRIBA ANTES DE INSERTARLA EN EL ORIFICIO DEL TABLERO.

PASO 3

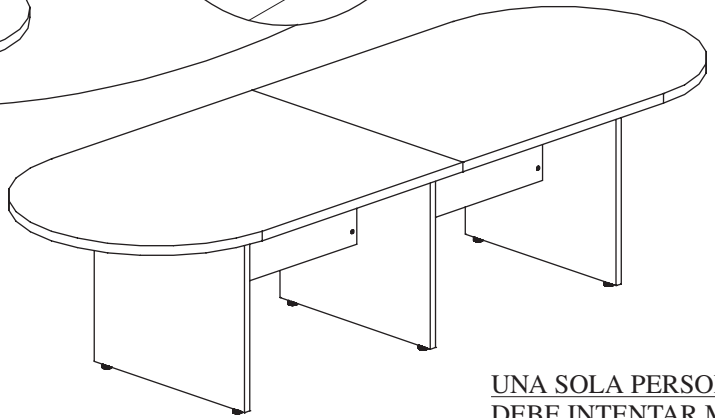
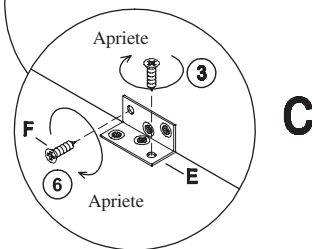

ENSAMBLE COMPLETO

UNA SOLA PERSONA NO DEBE INTENTAR MOVER LA MESA.

NOTA IMPORTANTE:

- Coloque todas las partes laminadas sobre una superficie limpia y uniforme (como un tapete o la alfombra) para evitar que se rayen.
- Asegúrese de tener todas las partes y la ferretería.
- Antes de empezar a ensamblar remueva todos los materiales de empaque, incluyendo grapas y cintas.
- No apriete todos los tornillos o pernos hasta haber ensamblado todas las piezas.
- Mantenga toda la ferretería fuera del alcance de los niños.
- Se recomienda que dos personas realicen este ensamble.



Instructions

IF YOU ARE MISSING PARTS OR OTHER CONCERNS PLEASE CALL OUR TOLL FREE NUMBER: 1-888-295-5839. MONDAY– FRIDAY 9:00 AM TO 4:00 PM – EASTERN STANDARD TIME. Parts request can be sent via email to Parts@sprich.com or fax your request to (404) 472-9063.

Please provide the following information on the following page:

1. Full Name
2. Physical Address – do not include P.O. Box as our carriers cannot deliver to a P.O. Boxes
3. Phone Number
4. Model Number
5. Part Number
6. Invoice #
7. Date of Purchase

Note: Our policy is to send all parts requests normal ground transportation, if your requirements are to have these parts via overnight/next day, please provide your designated carrier and account number. Replacement panels are not available. If damaged has occurred during shipment, please return the entire unit to place of purchase for credit and replacement. Original Invoice may be required.

Before you begin:

Open, identify and count all parts prior to assembly. Lay out the parts on a non-abrasive surface such as carpet or blanket.

Instructions

APPELEZ À NOTRE NUMÉRO SANS FRAIS S'IL VOUS MANQUE DES PIÈCES OU SI VOUS ÉPROUVEZ D'AUTRES INQUIÉTUDES: 1-888-295-5839. LUNDI – VENDREDI, 9:00 AM À 4:00 PM – HEURE NORMALE DE L'EST. La demande de pièces peut être envoyée via un courriel à Parts@sprich.com ou télécopiez votre demande au (404) 472-9063.

Veillez fournir l'information suivante sur la page suivante:

1. Nom complet
2. Adresse physique – ne donnez pas votre boîte postale car nos livreurs ne peuvent pas livrer à une boîte postale
3. Numéro de téléphone
4. Numéro de modèle
5. Numéro de pièce
6. # de facture
7. Date de l'achat

Note: Notre politique est de livrer toutes les demandes de pièces par la voie terrestre; prière de fournir le nom de votre transporteur ainsi que votre numéro de compte si vos exigences sont d'avoir ces pièces livrées pendant la nuit/le lendemain. Des panneaux de remplacement ne sont pas disponibles. Si des dommages sont survenus durant le transport, prière de retourner l'unité entière à l'endroit de l'achat pour un crédit et un remplacement. La facture originale peut être exigée.

Avant de commencer:

Ouvrez, identifiez et comptez toutes les pièces avant de procéder à l'assemblage. Disposez les pièces sur une surface non-abrasive telle un tapis ou une couverture.

Instrucciones

SI LE FALTAN PARTES O TIENE ALGUNA DUDA, LLAME A NUESTRA LÍNEA GRATUITA AL NÚMERO: 1-888-295-5839. LUNES AVIERNES DE 9:00 A 16:00 – HORA ESTÁNDAR DEL ESTE. La solicitud de partes de repuesto puede enviarse vía correo electrónico a Parts@sprich.com o por fax al (404) 472-9063.

Proporcione la siguiente información en la siguiente página:

1. Nombre completo
2. Domicilio. No incluye apartado postal debido a que nuestros distribuidores no pueden hacer entregas a un apartado postal.
3. Número telefónico
4. Número de modelo
5. Número de parte
6. No. de factura
7. Fecha de compra

Nota: Nuestra política establece enviar todas las partes solicitadas vía terrestre. Si sus requisitos incluyen tener estas partes con un envío nocturno o al día siguiente, sírvase proporcionar su transportista asignado y número de cuenta.

No se cuenta con tableros de repuesto. Si la unidad sufrió algún daño durante el envío, regrésela completa a donde la adquirió para que le reembolsen su pago y se la reemplacen. Se le podría solicitar su factura original.

Antes de iniciar:

Abra, identifique y cuente todas las partes antes del ensamble. Coloque todas las partes en una superficie no abrasiva, como una alfombra o sábana.