

Installation Instructions / Warranty

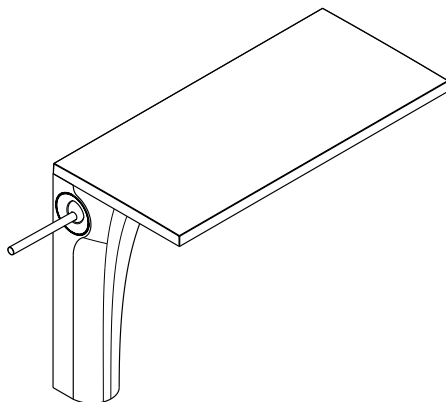

Massaud
18020001

hangrohe

Axor Massaud Single-Control Highriser Lavatory Faucet 18020XX1

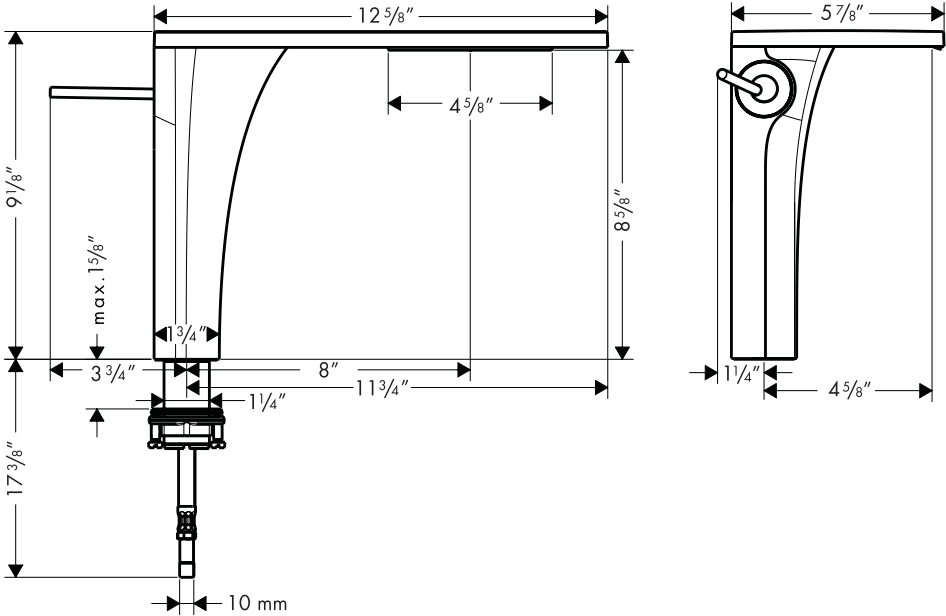

Product Specification

Max. Flow Rate	2.2 gpm	
Max. incoming water pressure		145 psi
Recommended water pressure		14.5 - 72 psi
Max. hot water temperature		176° F*
Recommended hot water temp		120°F - 140°F*
Hole size in mounting surface		1 3/8"
Max. mounting surface thickness		1 5/8"
10 mm supply hoses – 10 mm - 3/8" adapters included.		
No drain or pull rod is included.		

This faucet may be used with a continuous flow water heater if the flow pressure is at least 20 psi.

*Know and follow all applicable local plumbing codes when setting the temperature on the water heater. In Massachusetts, the water heater may be set no higher than 112°F.

Do not allow the supply hoses to bend or twist!

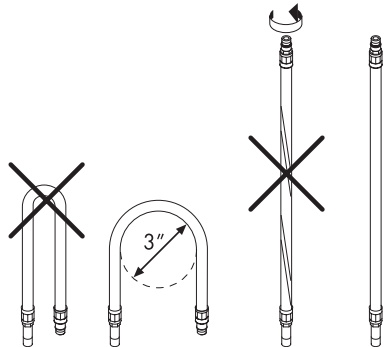

Installation

Position the faucet and sealing ring on the mounting surface.

From beneath the mounting surface, install the fiber washer, metal washer, and mounting nut. Tighten the tensioning screws.

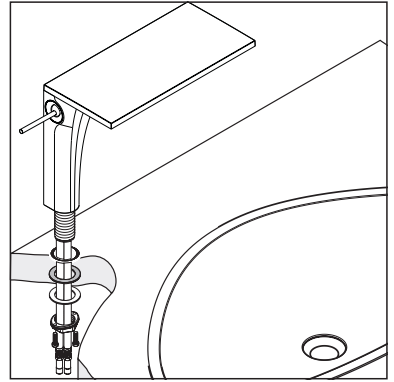

Install the adapters on the stops. Install the filters on the adapters.

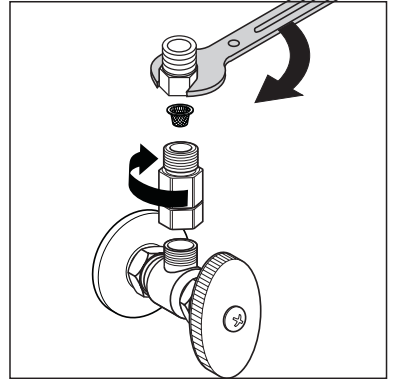

Slide the compression nut, cone washer, metal washer, and rubber washer over the end of the supply hose. Place the supply hose in the filter.

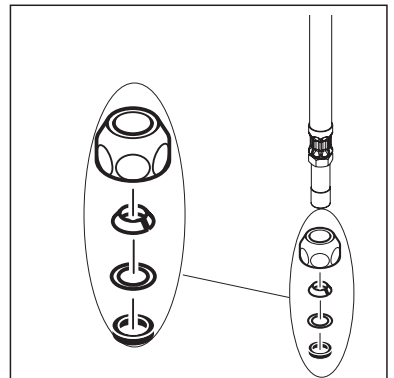

Tighten the compression nut to the filter, using two wrenches, as shown in the diagram, to prevent the supply hose from twisting.

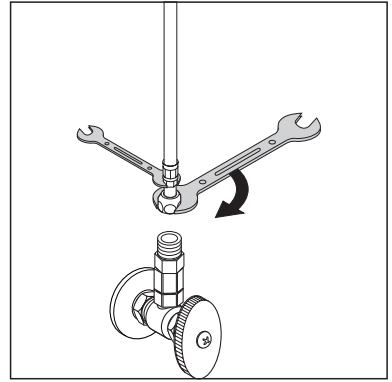

Turn on the water and check all connections for leaks.

User Instructions

Pivot the handle upward to turn the water on, downward to turn the water off.

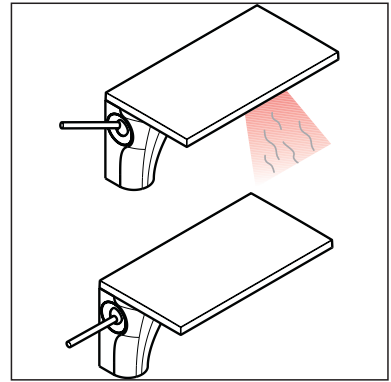

Pivot the handle to the rear for warmer water, to the front for cooler water.

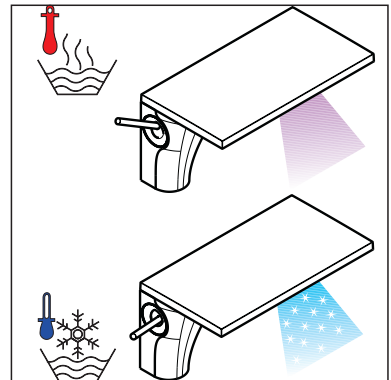

If the flow of water decreases over time, remove and clean the filter screen.

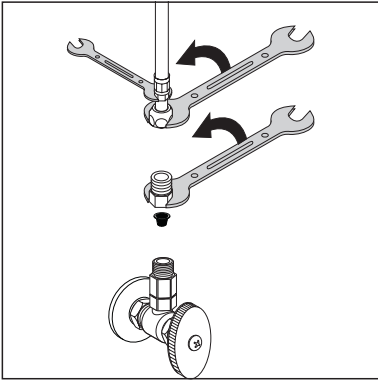

Replacement Parts

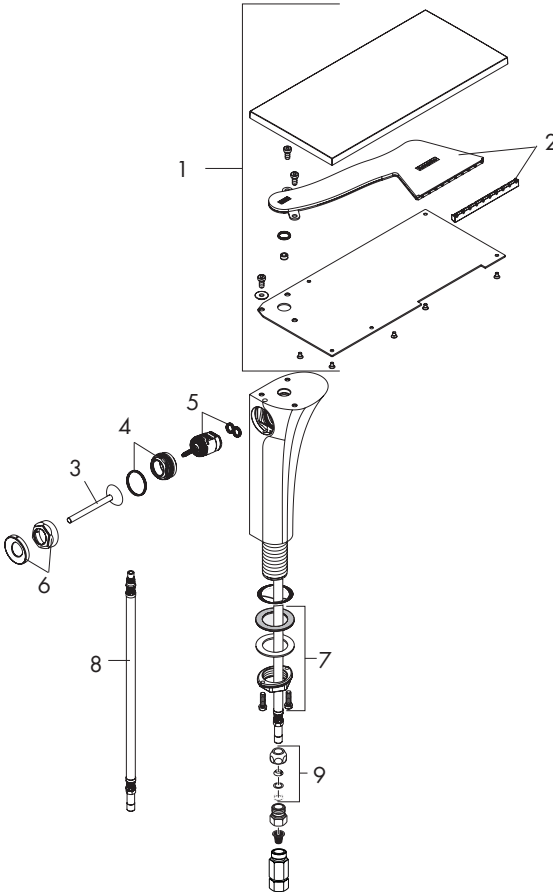

1	spout	98652000
2	diffuser	97445000
3	handle	18093000
4	nut	97157000
5	cartridge	96339000
6	flange	98650000
7	fixing set	13961000
8	supply hose	98600000
9	hose fixing set	94158000

Cleaning Recommendation for Hansgrohe Products

Modern sanitary faucetry and shower fixtures consist of very different materials to comply with the needs of the market with regard to design and functionality.

To avoid damage and returns, it is necessary to consider certain points when cleaning:

Cleaning materials for faucets and shower products:

Acids are necessary ingredients of cleaning materials for removing lime. However, please pay attention to the following points when cleaning faucets and shower products:

- Use only cleaning materials intended for the application.
- Never use cleaning materials which contain hydrochloric, formic, or phosphoric, or acetic acid, as these can cause considerable damage.
- Do not mix one cleaning material with another.
- Do not use abrasives, such as cleaning powders, sponge pads, or microfiber cloths.

Cleaning Instructions for Faucets and Shower Products:

Please follow the cleaning material manufacturer's instructions. In addition, please note the following:

- Clean your faucets and shower products as and when required.
- Follow the label instructions. Do not allow any cleaner to remain on the product for longer than necessary.
- Regular cleaning will prevent scale buildup and water spotting.
- When using spray cleaners, spray first onto a sponge or cloth. Do not spray directly onto the faucet or shower product as drops could enter openings or gaps and cause damage.
- After cleaning, rinse thoroughly with clear water to remove any cleaner residue.

Important

Residues of liquid soaps, shampoos, and shower foams can also cause damage, so rinse with clean water after using.

Please note:

- If the surface is already damaged, the effect of cleaning materials will cause further damage.
- Components with damaged surfaces must be replaced, otherwise, this could cause injury.
- Damage caused by improper treatment will not be covered by our warranty.

Limited Lifetime Consumer Warranty

This product has been manufactured and tested to the highest quality standards by Hansgrohe, Inc. ("Hansgrohe"). This warranty is limited to Hansgrohe products which are purchased by a consumer in the United States after March 1, 1996, and installed in either the United States or Canada.

WHO IS COVERED BY THE WARRANTY

This warranty extends to the original consumer purchaser only. This warranty is non-transferable.

WHAT IS COVERED BY THE WARRANTY

This warranty covers only your Hansgrohe manufactured product. Hansgrohe warrants this product against defects in material or workmanship as follows: Hansgrohe will repair at no charge for parts only or, at its option, replace any product or part of the product that proves defective because of improper workmanship and/or material, under normal installation, use, service and maintenance. If Hansgrohe is unable to provide a replacement and repair is not practical or cannot be timely made, Hansgrohe may elect to refund the purchase price in exchange for the return of the product.

LENGTH OF WARRANTY

Replacement or repaired parts of products will be covered for the term of this warranty as stated in the following two sentences. If you are a consumer who purchased the product for use primarily for personal, family, or household purposes, this warranty extends for as long as you own the product and the home in which the product is originally installed. If you purchased the product for use primarily for any other purpose, including, without limitation, a commercial purpose, this warranty extends only (i) for 1 year, with respect to Hansgrohe and Commercial products, and (ii) for 5 years, with respect to AXOR products.

THIS WARRANTY DOES NOT COVER, AND HANSGROHE WILL NOT PAY FOR:

- A. Conditions, malfunctions or damage not resulting from defects in material or workmanship.
- B. Conditions, malfunctions or damage resulting from (1) normal wear and tear, improper installation, improper maintenance, misuse, abuse, negligence, accident or alteration, or (2) the use of abrasive or caustic cleaning agents or "no-rinse" cleaning products, or the use of the product in any manner contrary to the product instructions. (3) Conditions in the home such as excessive water pressure or corrosion.
- C. Labor or other expenses for the disconnection, deinstallation, or return of the product for warranty service, or for installation or reinstallation of the product (including but not limited to proper packaging and shipping costs), or for installation or reinstallation of the product.
- D. Accessories, connected materials and products, or related products not manufactured by Hansgrohe.

TO OBTAIN WARRANTY PARTS OR INFORMATION

Contact your Hansgrohe retailer, or contact Technical Service at:

Hansgrohe Inc.
1492 Bluegrass Lakes Parkway
Alpharetta GA 30004
Toll-free (800) 334-0455.

In requesting warranty service, you will need to provide

1. The sales receipt or other evidence of the date and place of purchase.
2. A description of the problem.
3. Delivery of the product or the defective part, postage prepaid and carefully packed and insured, to Hansgrohe Inc. 1492 Bluegrass Lakes Parkway, Alpharetta, Georgia 30004, Attention: Technical Service, if required by Hansgrohe.

When warranty service is completed, any repaired or replacement product or part will be returned to you postage prepaid.

EXCLUSIONS AND LIMITATIONS

REPAIR OR REPLACEMENT (OR, IN LIMITED CIRCUMSTANCES, REFUND OF THE PURCHASE PRICE) AS PROVIDED UNDER THIS WARRANTY IS THE EXCLUSIVE REMEDY OF THE PURCHASER. HANSGROHE NEITHER ASSUMES NOR AUTHORIZES ANY PERSON TO CREATE FOR IT ANY OBLIGATION OR LIABILITY IN CONNECTION WITH THIS PRODUCT.

HANSGROHE SHALL NOT BE LIABLE TO PURCHASER OR ANY PERSON FOR ANY INCIDENTAL, SPECIAL, OR CONSEQUENTIAL DAMAGES, ARISING OUT OF BREACH OF THIS WARRANTY OR ANY IMPLIED WARRANTY (INCLUDING MERCHANTABILITY).

Some States do not allow the exclusion or limitation of incidental or consequential damages, so the above limitation or exclusion may not apply to you. This warranty gives you specific legal rights, and you may have other rights which vary from State to State. You may be required by law to give us a reasonable opportunity to correct or cure any failure to comply before you can bring any action in court against us under the Magnuson-Moss Warranty Act.

PRODUCT INSTRUCTIONS AND QUESTIONS

Upon purchase or prior to installation, please carefully inspect your Hansgrohe product for any damage or visible defect. Prior to installing, always carefully study the enclosed instructions on the proper installation and the care and maintenance of the product. If you have questions at any time about the use, installation, or performance of your Hansgrohe product, or this warranty, please call or write to us or call us toll-free at 800 334 0455.

hansgrohe

Hansgrohe, Inc. • 1490 Bluegrass Lakes Parkway • Alpharetta, GA 30004
Tel. 770 360-9880 • Fax 770 360 9887

www.hansgrohe-USA.com